



Membrane Air Dryer *Series IDG*

**Macromolecular membrane
dryers that act like filters**



New 10, 600, 750 & 1000 /min (ANR) models added to IDG Series!

Membrane Air Dryer Series *IDG*

Power supply not required

A power supply is completely unnecessary. Wiring labor is not required and there is no need to consider electrical specifications, etc.

No vibration or exhaust heat

There are no mechanical moving parts as in the case of refrigeration equipment.

Dew point indicator confirms air drying at a glance

(except IDG1)
(optional on IDG5, IDG5H)

Also available with fittings for purge air discharge

When purge air discharge is undesirable in the area around the membrane air dryer, it can be discharged to atmosphere via tubing (optional).

Integrated pre-filter

Also available as a unit in which pre-filters (AFM, AFD, AMH) are combined with the membrane air dryer.



IDG10V

IDG30M

IDG60M

Environmentally friendly (non-freon)

- Compact
- Lightweight
- Space saving

Compatible with low dew points

Compatible with outlet air atmospheric pressure dew points as low as -40°C .
(IDG30L, IDG50L, IDG60L)
IDG75L, IDG100L)

Discharged air noise reduced with built-in silencer

(Except IDG1, IDG5, IDG5H, IDG30, IDG30H, IDG30L, IDG50, IDG50H, IDG50L)

Applications

- Precision machines (air bearings, lasers, etc.)
- Precision measuring equipment (3-D measuring machines)
- Semiconductor manufacturing equipment
- Semiconductor inspection equipment
- Chemical analysis equipment
- Ozonizers
- Packaging machines
- Paper making machines
- Fine particle transfer equipment
- Electrostatic and high grade coating
- Drying and cleaning of precision parts
- Condensation prevention in control panels
- General pneumatic equipment and pneumatic tools

Features 1

Dehumidification principle

The membrane air dryer uses hollow fibers composed of a macromolecular membrane through which moisture passes easily, but is difficult for air (oxygen and nitrogen) to pass through.

When humid, compressed air is supplied to the inside of the hollow fibers, only moisture permeates the membrane and moves to the outside due to the pressure difference between the moisture inside and outside of the fibers. The compressed air becomes dry air and continues out of the dryer. Part of the dry air from the outlet side is passed through a very small orifice to reduce the pressure and purge the outside of the hollow fibers. The moisture which permeated to the outside of the hollow fibers is discharged to the atmosphere by this purging air. In this way, the partial pressure outside of the hollow fibers is always kept low, and dehumidification is performed continuously.

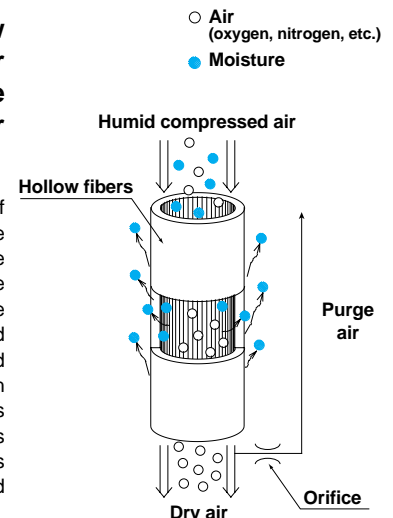

Series Variations

Single Style

Series IDG



Standard Purging		Low Purging		Low Dew Point	
Standard dew point: -20°C ^{Note)} Standard purging rate: 20%		Standard dew point: -15°C ^{Note)} Standard purging rate: 10%		Standard dew point: -40°C ^{Note)} Standard purging rate: 25%	
Series	Outlet air flow rate /min (ANR) ^{Note)}	Series	Outlet air flow rate /min (ANR) ^{Note)}	Series	Outlet air flow rate /min (ANR) ^{Note)}
IDG1	10	IDG5H	50	IDG30L	75
IDG5	50	IDG10H	100	IDG50L	110
IDG10	100	IDG20H	200	IDG60L	170
IDG20	200	IDG30H	300	IDG75L	240
IDG30	300	IDG50H	500	IDG100L	300
IDG50	500	IDG60H	600		
IDG60	600	IDG75H	750		
IDG75	750	IDG100H	1000		
IDG100	1000				

Unit Style

IDG/M Type

A mist separator and micro mist separator, or micro mist separator with pre-filter are combined with the single styles

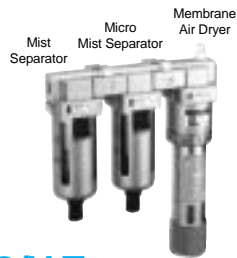

IDG5M	50	IDG5HM	50	IDG30LM	75
IDG10M	100	IDG10HM	100	IDG50LM	110
IDG20M	200	IDG20HM	200	IDG60LM	170
IDG30M	300	IDG30HM	300	IDG75LM	240
IDG50M	500	IDG50HM	500	IDG100LM	300
IDG60M	600	IDG60HM	600		
IDG75M	750	IDG75HM	750		
IDG100M	1000	IDG100HM	1000		

IDG/V Type

A regulator is combined with the M type



IDG5V	50	IDG5HV	50	IDG30LV	75
IDG10V	100	IDG10HV	100	IDG50LV	110
IDG20V	200	IDG20HV	200	IDG60LV	170
IDG30V	300	IDG30HV	300	IDG75LV	240
IDG50V	500	IDG50HV	500	IDG100LV	300
IDG60V	600	IDG60HV	600		
IDG75V	750	IDG75HV	750		
IDG100V	1000	IDG100HV	1000		

Note) Standard dew point: Outlet air atmospheric pressure dew point under standard performance conditions
Standard purging rate: Ratio of purge air flow rate to inlet air flow rate under standard performance conditions
Outlet air flow rate: Value under standard performance conditions

Table of Contents

Single Style	Unit Style	Model Selection Method
Standard Dew Point - 20°C Specifications	How to Order P.12	Model Selection P.28
How to Order, Accessory Part Nos. P. 1	Standard Specifications (Standard Dew Point - 20°C) P.13	Flow Rate Characteristics P.30
Standard Specifications P. 1	Replacement Part Nos. P.13	Purge Air Flow Rate Charts P.32
Performance Charts P. 2	Standard Specifications (Standard Dew Point - 15°C) P.14	
Standard Dew Point - 15°C Specifications	Replacement Part Nos. P.14	
How to Order, Accessory Part Nos. P. 4	Standard Specifications (Standard Dew Point - 40°C) P.15	Precautions
Standard Specifications P. 4	Replacement Part Nos. P.15	Safety Instructions P.34
Performance Charts P. 5	Flow Rate Characteristics P.16	Cleaning Equipment Precautions P.35
Standard Dew Point - 40°C Specifications	Dimensions (M Type) P.18	Specific Product Precautions P.37
How to Order, Accessory Part Nos. P. 6	Dimensions (V Type) P.23	
Standard Specifications P. 6		
Performance Charts P. 7		
Construction P. 8		
Dimensions P.10		

Membrane Air Dryer Series **IDG**

Single Style/Standard Dew Point – 20°C Specifications

How to Order

IDG 10 — **03**

• **Flow rate by size**

Size	/min (ANR)	
	Outlet air flow rate	Purge air flow rate
1	10/2.5	
5	50/12	
10	100/25	
20	200/50	
30	300/75	
50	500/125	
60	600/125	
75	750/150	
100	1000/190	

• **Optional specifications**

Symbol	Contents	Sizes								
		1	5	10	20	30	50	60	75	100
Nil	Standard	●	●	●	●	●	●	●	●	●
P	With fitting for purge air discharge	●	●	●	●	●	●	●	●	●
R	Flow direction (right→left)	—	●	●	●	●	●	●	●	●
S	With dew point indicator	—	●							

Note) In case of two or more options, indicate in alphabetical order.

• **Accessories**

Nil	None (standard)
B	With bracket (except IDG1)

Note) When symbol B is indicated, a bracket assembly with a part number shown in the table below is included as an accessory.

• **Thread type**

Nil	Rc
N	NPT
F	G

• **Port size**

Symbol	Bore	Sizes								
		1	5	10	20	30	50	60	75	100
01	1/8	—	●	—	—	—	—	—	—	—
02	1/4	●	●	●	●	●	—	—	—	—
03	3/8	—	—	●	●	●	●	—	—	—
04	1/2	—	—	—	—	—	●	●	●	—



IDG1



IDG10



IDG30

JIS symbol

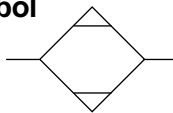

Bracket assembly (accessory) part nos.

Part No.	Applicable models
BM59	IDG5, IDG5H
BM61	IDG10, IDG10H
BM63	IDG20, IDG20H
BM64	IDG30, IDG30H, IDG30L
	IDG50, IDG50H, IDG50L
BM65	IDG60, IDG60H, IDG60L
	IDG75, IDG75H, IDG75L
	IDG100, IDG100H, IDG100L

* With cap bolts and spring washers

Standard Specifications/Single Style (Standard Dew Point – 20°C)

Model		Standard Dew Point – 20°C								
		IDG1	IDG5	IDG10	IDG20	IDG30	IDG50	IDG60	IDG75	IDG100
Range of operating conditions	Fluid	Compressed air								
	Inlet air pressure MPa	0.3 to 0.85				0.3 to 1.0				
	Inlet air temperature ^{Note 1)}	– 5 to 55°C				– 5 to 50°C				
Standard performance	Ambient temperature	– 5 to 55°C				– 5 to 50°C				
	Outlet air atmospheric pressure dew point	– 20°C								
Standard performance conditions	Inlet air flow rate /min (ANR) ^{Note 2)}	12.5	62	125	250	375	625	725	900	1190
	Outlet air flow rate /min (ANR)	10	50	100	200	300	500	600	750	1000
	Purge air flow rate /min (ANR) ^{Note 3)}	2.5	12	25	50	75	125	125	150	190
	Inlet air pressure MPa	0.7								
	Inlet air temperature	25°C								
	Inlet air saturation temperature	25°C								
	Ambient temperature	25°C								
Dew point indicator purge air flow rate	—	1 /min (ANR) (inlet air pressure at 0.7MPa)								
Port size (nominal size B)	1/4	1/8, 1/4	1/4, 3/8			3/8, 1/2		1/2		
Weight kg (with bracket)	0.11	0.25 (0.31)	0.43 (0.51)	0.66 (0.76)	0.74 (0.87)	0.77 (0.90)	1.50 (1.65)	1.50 (1.65)	1.55 (1.70)	

Note 1) With no freezing.

Note 2) ANR indicates the flow rate converted to the value for 20°C at atmospheric pressure.

Note 3) Includes dew point indicator purge air flow rate of 1 /min (ANR) (inlet air pressure at 0.7MPa) (except IDG1, IDG5).

Series IDG

Performance Charts

IDG1

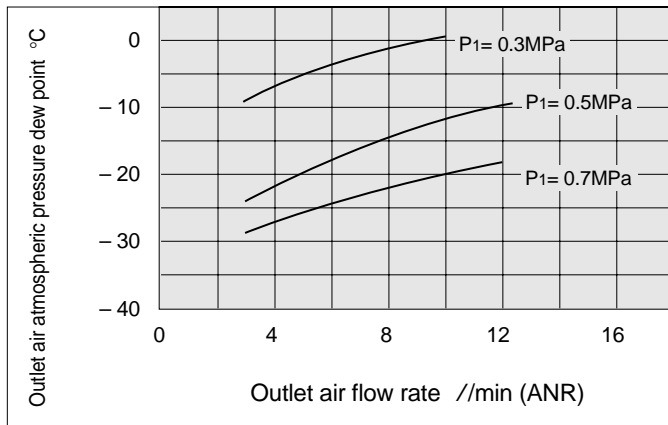

IDG5

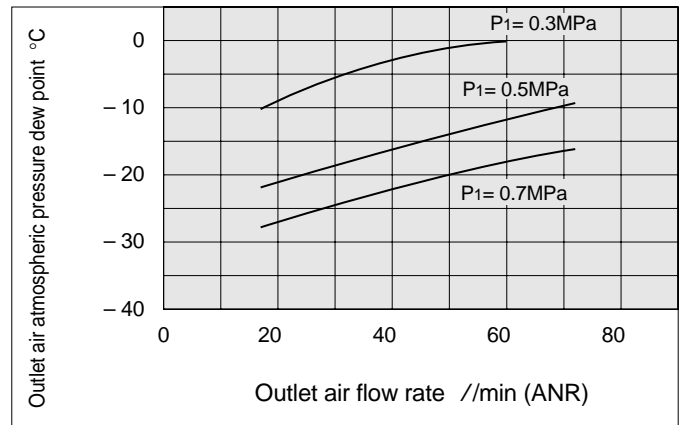

IDG10

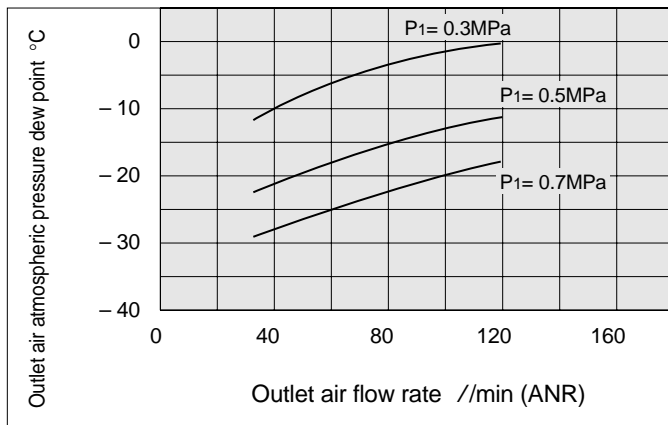

IDG20

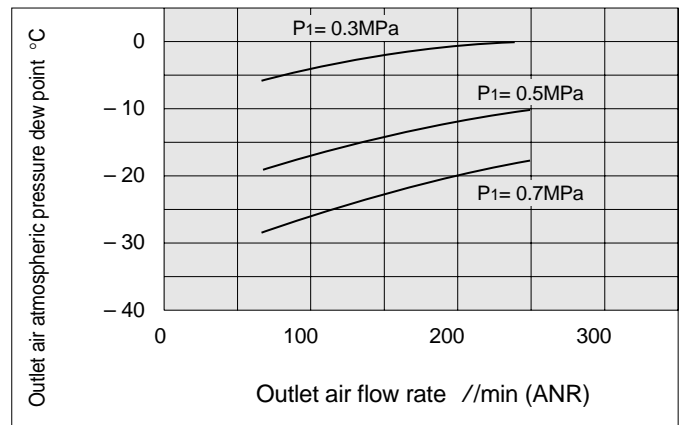

IDG30

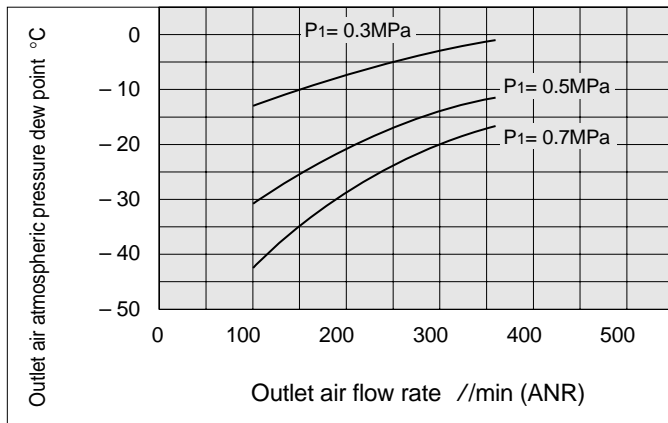

IDG50

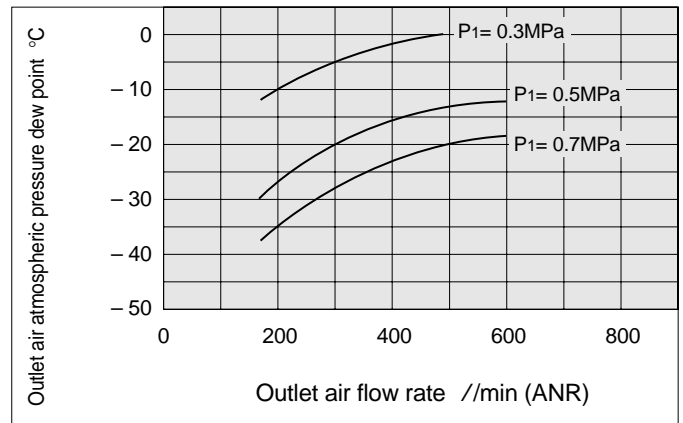

IDG60

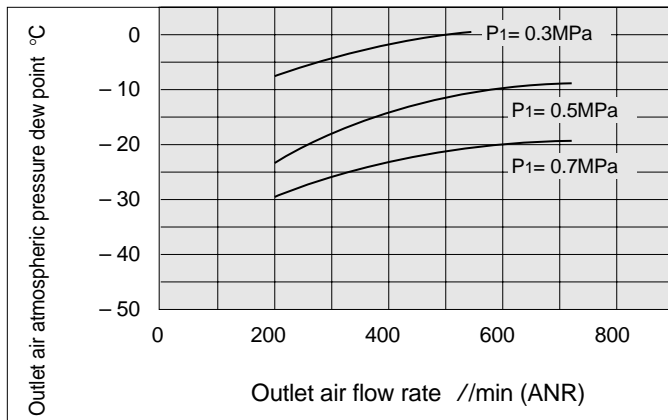

IDG75

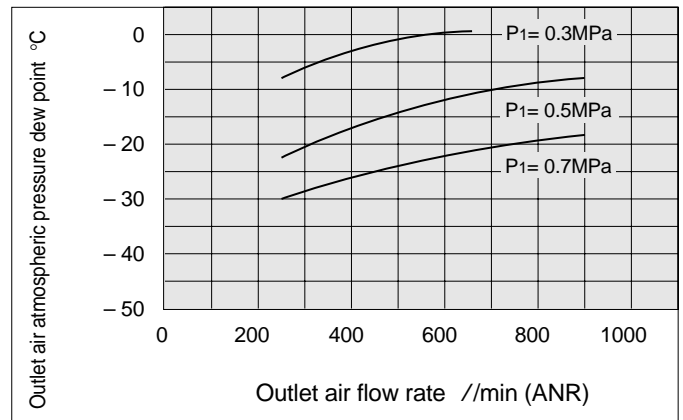

Conditions: Inlet air temperature 25°C (saturated air), Ambient temperature 25°C, P₁: Inlet air pressure

Note: Refer to page 3 when equipped with fitting for purge air discharge (Option: P).

IDG100

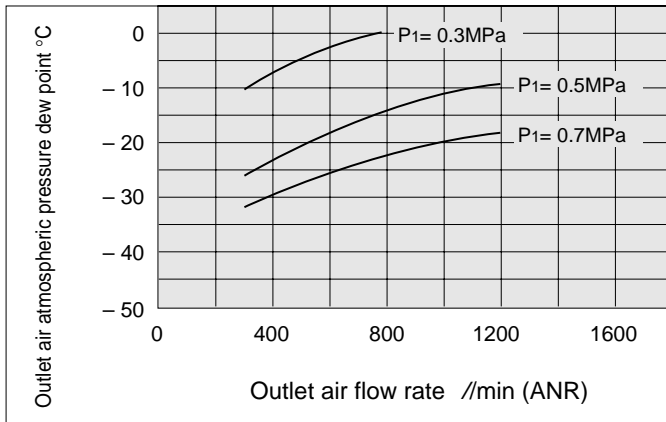

With fitting for purge air discharge (Option: P)

As the length of tubing for purge air discharge becomes longer, the outlet air atmospheric pressure dew point becomes higher. Refer to the table below.

Outlet air atmospheric pressure dew point by purge air discharge tube length °C

Tube length	Model	IDG30	IDG50
0m		-20	-20
1m		-19	-19
3m		-17	-17
5m		-16	-16

Note) In case of models other than the above, the outlet air atmospheric pressure dew point will increase by 1°C or less for tubing lengths of 5m or less.

■ Conditions

Inlet air temperature: 25°C (saturated)

Ambient temperature: 25°C

Inlet air pressure: 0.7MPa

Outlet air flow rate: Flow rate for standard performance conditions (Refer to page 1.)

Tubing size (O.D. x I.D.) mm: ø12 x ø9

Single Style/Standard Dew Point -15°C Specifications

How to Order

IDG 10 H — **03** —

Flow rate by size

Size	Outlet air flow rate Purge air flow rate /min (ANR)
5	50/6
10	100/11
20	200/22
30	300/35
50	500/60
60	600/65
75	750/80
100	1000/110

Standard dew point temperature

Symbol	Standard dew point °C
H	-15

Thread type

Nil	Rc
N	NPT
F	G

Optional specifications

Nil	None (standard)
P	With fitting for purge air discharge
R	Flow direction (right→left)
S	With dew point indicator (applicable only for size 5, standard equipment for all others)

Note) In case of two or more options, indicate in alphabetical order.

Accessories

Nil	None (standard)
B	With bracket

Note) When symbol B is indicated, a bracket assembly with a part number shown in the table below is included as an accessory.

Port size

Symbol	Bore	Sizes							
		5	10	20	30	50	60	75	100
01	1/8	●	—	—	—	—	—	—	—
02	1/4	●	●	●	●	●	—	—	—
03	3/8	—	●	●	●	●	●	—	—
04	1/2	—	—	—	—	—	●	●	●

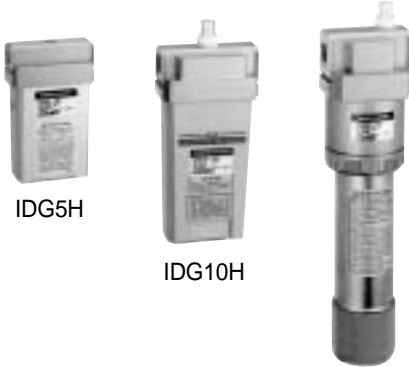

JIS symbol

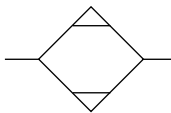

Bracket assembly (accessory) part nos.

Part No.	Applicable models
BM59	IDG5, IDG5H
BM61	IDG10, IDG10H
BM63	IDG20, IDG20H
BM64	IDG30, IDG30H, IDG30L IDG50, IDG50H, IDG50L
BM65	IDG60, IDG60H, IDG60L IDG75, IDG75H, IDG75L IDG100, IDG100H, IDG100L

* With cap bolts and spring washers

Standard Specifications/Single Style (Standard Dew Point -15°C)

Model		Standard dew point -15°C							
		IDG5H	IDG10H	IDG20H	IDG30H	IDG50H	IDG60H	IDG75H	IDG100H
Range of operating conditions	Fluid	Compressed air							
	Inlet air pressure MPa	0.3 to 0.85				0.3 to 1.0			
	Inlet air temperature ^{Note 1)}	-5 to 55°C				-5 to 50°C			
	Ambient temperature	-5 to 55°C				-5 to 50°C			
Standard performance	Outlet air atmospheric pressure Dew point	-15°C							
	Inlet air flow rate /min (ANR) ^{Note 2)}	56	111	222	335	560	665	830	1110
Standard performance conditions	Outlet air flow rate /min (ANR)	50	100	200	300	500	600	750	1000
	Purge air flow rate /min (ANR) ^{Note 3)}	6	11	22	35	60	65	80	110
	Inlet air pressure MPa	0.7							
	Inlet air temperature	25°C							
	Inlet air saturation temperature	25°C							
	Ambient temperature	25°C							
Dew point indicator purge air flow rate		1 /min (ANR) {inlet air pressure at 0.7MPa}							
Port size (nominal size B)		1/8, 1/4	1/4, 3/8			3/8, 1/2		1/2	
Weight kg (with bracket)		0.25 (0.31)	0.43 (0.51)	0.66 (0.76)	0.74 (0.87)	0.77 (0.90)	1.50 (1.65)	1.50 (1.65)	1.55 (1.70)

Note 1) With no freezing.

Note 2) ANR indicates the flow rate converted to the value for 20°C at atmospheric pressure.

Note 3) Includes dew point indicator purge air flow rate of 1/min (ANR) (inlet air pressure at 0.7MPa) (except IDG5H).

Membrane Air Dryer Series IDG

Conditions: Inlet air temperature 25°C (saturated air), Ambient temperature 25°C, P₁: Inlet air pressure, Purge air discharge tube (Option: P): None

Note: When equipped with fitting for purge air discharge (Option: P), the outlet air atmospheric pressure dew point will rise by 1°C or less for tubing lengths of 5m or less.

Performance Charts

IDG5H

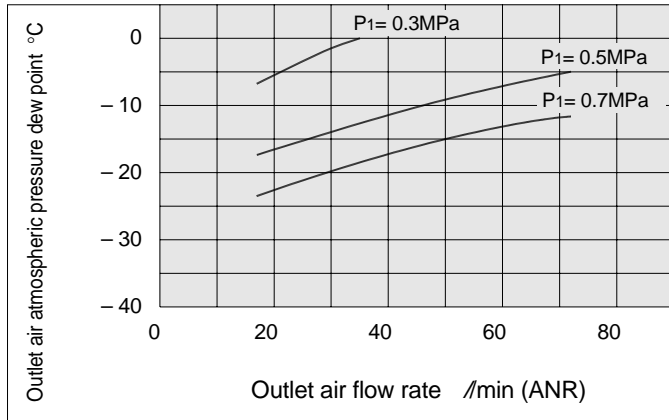

ID10H

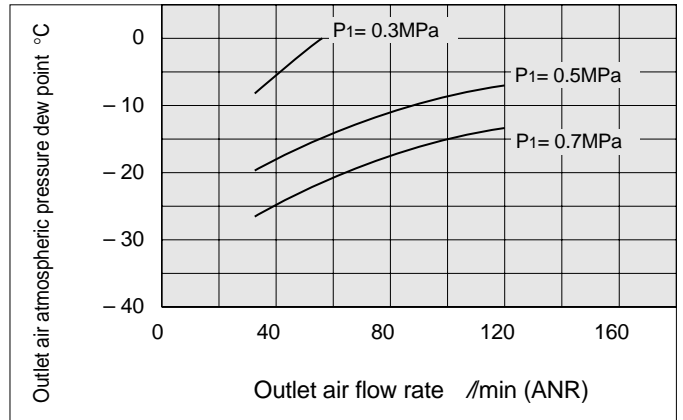

IDG20H

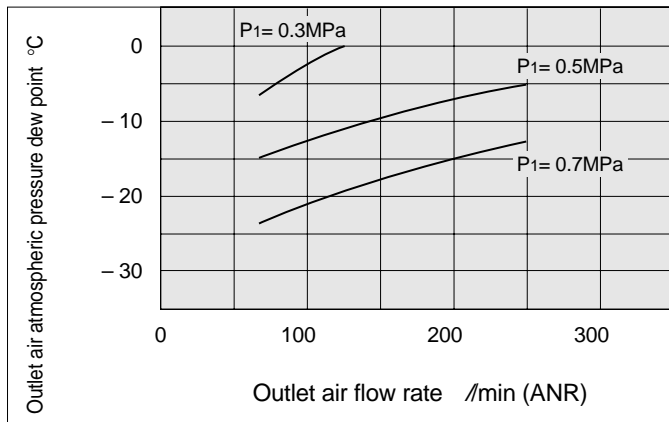

IDG30H

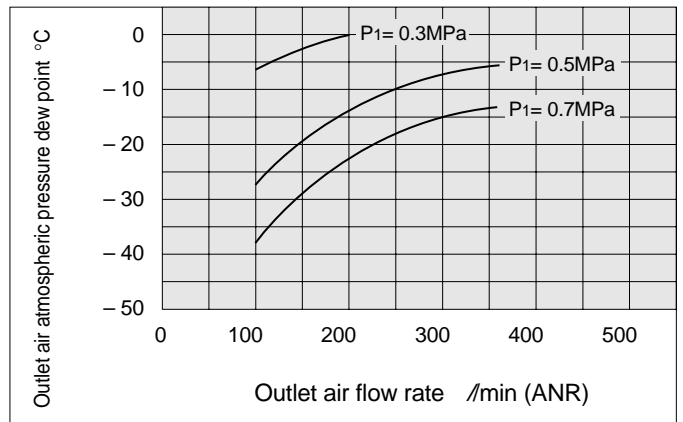

IDG50H

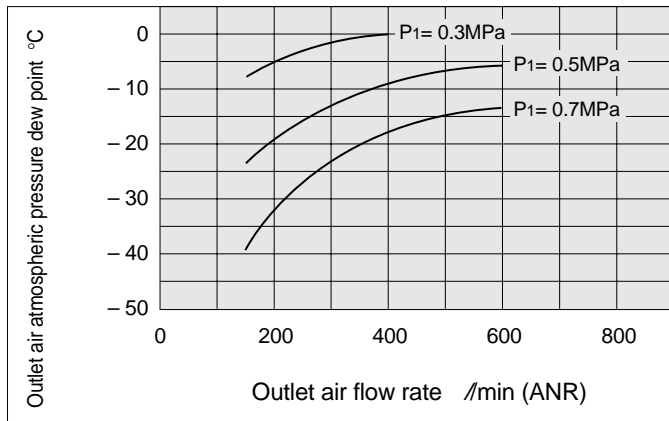

IDG60H

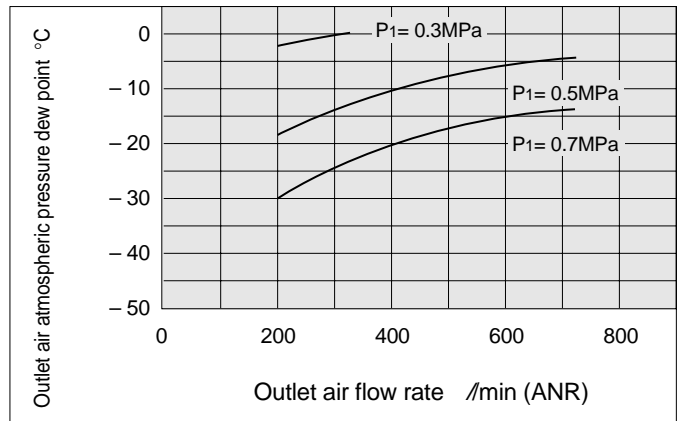

IDG75H

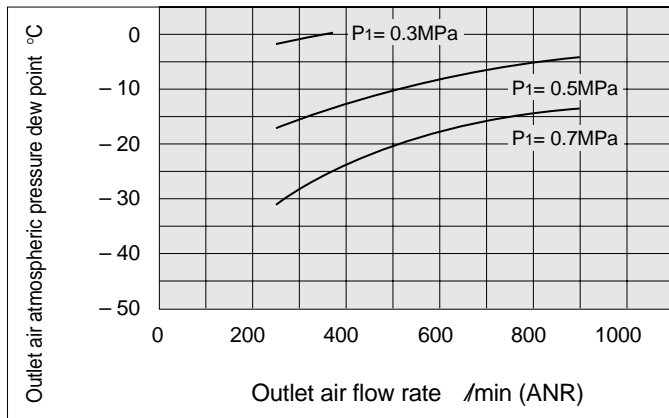

IDG100H

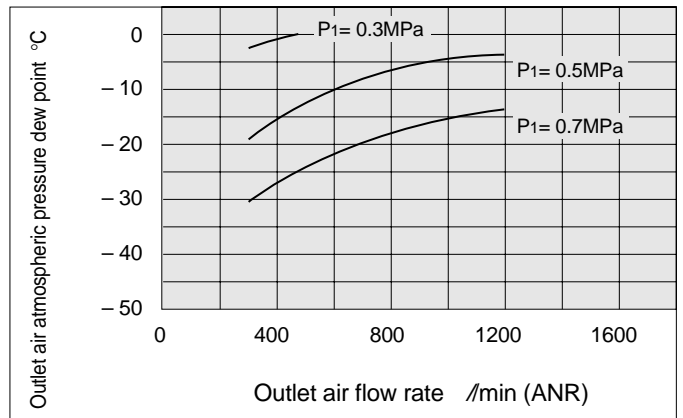

Single Style/Standard Dew Point –40°C Specifications

How to Order

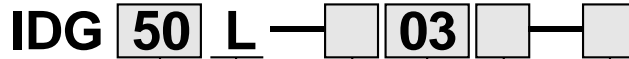

• **Flow rate by size**

Size	Outlet air flow rate Purge air flow rate /min (ANR)
30	75/25
50	110/40
60	170/57
75	240/80
100	300/100

• **Standard dew point temperature**

Symbol	Standard dew point °C
L	-40

• **Optional specifications**

Nil	None (standard)
P	With purge air discharge fitting
R	Flow direction (right→left)

Note) In case of two or more options, indicate in alphabetical order.

• **Accessories**

Nil	None (standard)
B	With bracket

Note) When symbol B is indicated, a bracket assembly with a part number shown in the table below is included as an accessory.

• **Port size**

Symbol	Bore	Sizes				
		30	50	60	75	100
02	1/4	●	●	—	—	—
03	3/8	●	●	●	●	●
04	1/2	—	—	●	●	●

• **Thread type**

Nil	Rc
N	NPT
F	G



IDG30L

JIS symbol

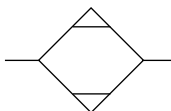

Bracket assembly (accessory) part nos.

Part No.	Applicable models
BM64	IDG30, IDG30H, IDG30L IDG50, IDG50H, IDG50L
BM65	IDG60, IDG60H, IDG60L IDG75, IDG75H, IDG75L IDG100, IDG100H, IDG100L

* With cap bolts and spring washers

Standard Specifications/Single Style (Standard dew point – 40°C)

Model		Standard dew point – 40°C				
		IDG30L	IDG50L	IDG60L	IDG75L	IDG100L
Range of operating conditions	Fluid	Compressed air				
	Inlet air pressure MPa	0.3 to 1.0				
	Inlet air temperature ^{Note 1)}	- 5 to 50°C				
	Ambient temperature	- 5 to 50°C				
Standard performance	Outlet air atmospheric pressure dew point	- 40 (- 50)°C ^{Note 4)}				
	Conditions for standard performance	Inlet air flow rate /min (ANR) ^{Note 2)}	100	150	227	320
Outlet air flow rate /min (ANR)		75	110	170	240	300
Purge air flow rate /min (ANR) ^{Note 3)}		25	40	57	80	100
Inlet air pressure MPa		0.7				
Inlet air temperature		25°C				
Inlet air saturation temperature		25°C				
Ambient temperature		25°C				
Dew point indicator purge air flow rate		1 /min (ANR) {inlet air pressure at 0.7MPa}				
Port size (nominal size B)		1/4, 3/8		3/8, 1/2		
Weight kg (with bracket)		0.74 (0.87)	0.77 (0.90)	1.50 (1.65)	1.65 (1.80)	1.80 (1.95)

Note 1) With no freezing.

Note 2) ANR indicates the flow rate converted to the value for 20°C at atmospheric pressure.

Note 3) Includes dew point indicator purge air flow rate of 1 /min (ANR) (inlet air pressure at 0.7MPa).

Note 4) Values inside () are applicable with a refrigeration type air dryer installed on the upstream side.

Conditions: Inlet air temperature 25°C (saturated air), Ambient temperature 25°C
 P1: Inlet air pressure, Tube for purge air discharge (Option: P): None

Performance Charts

IDG30L

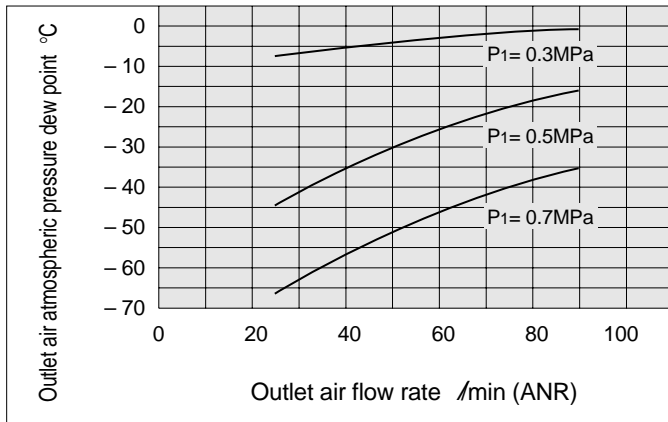

IDG50L

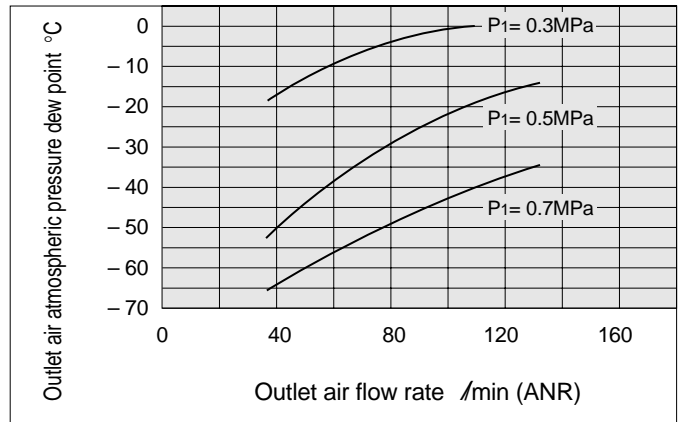

IDG60L

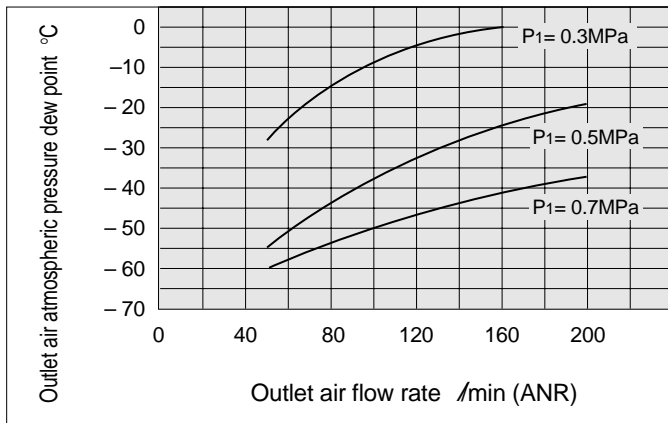

IDG75L

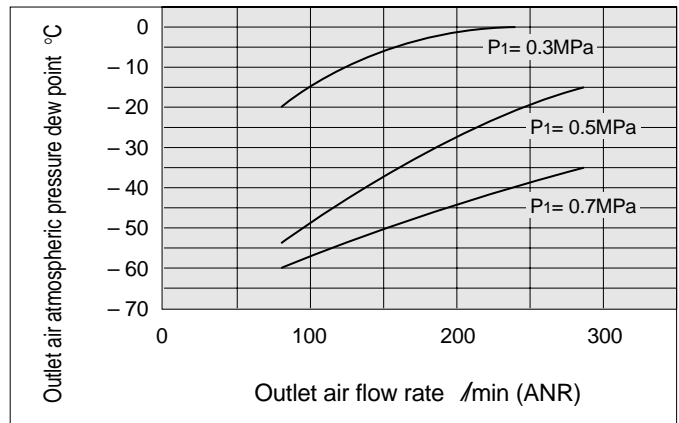

IDG100L

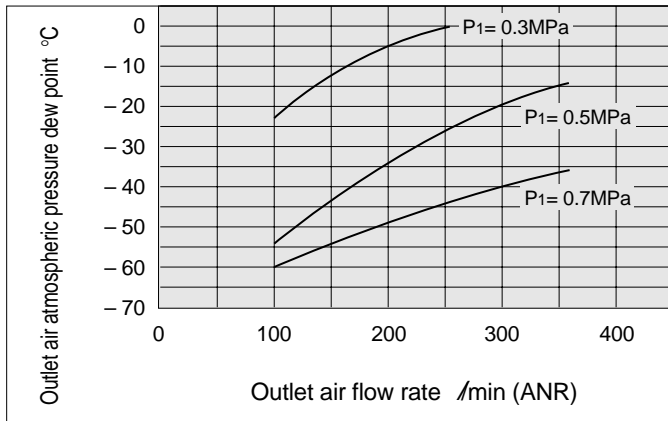

Fitting for purge air discharge (Option: P)

As the length of tubing for purge air discharge becomes longer, the outlet air atmospheric pressure dew point becomes higher. Refer to the table below.

Outlet air atmospheric pressure dew point °C by purge air discharge tube length

Tube length	Model	IDG30L	IDG50L
0m		-40	
1m		-39	
3m		-38	
5m			

Note) In case of models other than the above, the outlet air atmospheric pressure dew point will increase by 1°C or less for tubing lengths of 5m or less.

Conditions

- Inlet air temperature: 25°C (saturated)
- Ambient temperature: 25°C
- Inlet air pressure: 0.7MPa
- Outlet air flow rate: Flow rate for standard performance conditions (refer to page 6)
- Tubing size (O.D. x I.D.) mm: $\phi 12 \times \phi 9$

Series IDG

Construction

IDG1



Optional specifications
With fitting for purge air discharge (Option: P)

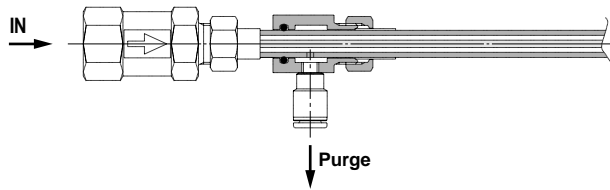

IDG5, IDG5H

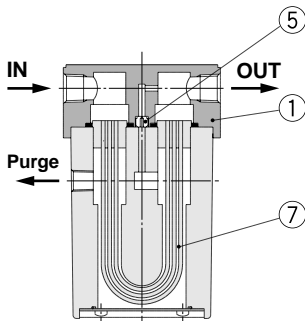

Optional specifications
With fitting for purge air discharge (Option: P)

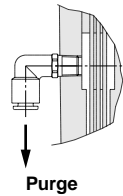

IDG10, IDG10H IDG20, IDG20H

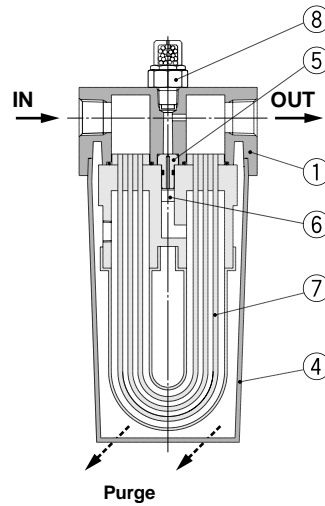

Optional specifications
With fitting for purge air discharge (Option: P)

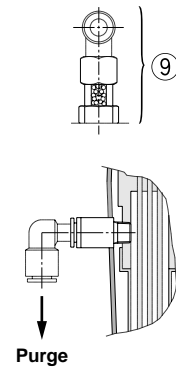

Parts list

No.	Description	Material				Note
		IDG1	IDG5, 5H	IDG10, 10H	IDG20, 20H	
1	Body	Copper alloy		Aluminum alloy		Platinum silver coating (IDG1 is electroless nickel plated)
2	Female connector	Copper alloy		—		Electroless nickel plated
3	Strainer	Copper alloy		—		
4	Case	—	—	Resin		
5	Orifice	Resin		Stainless		
6	Silencer	—	—	Copper alloy		

Replacement parts

No.	Description	Part Nos.				Note
		IDG1	IDG5, 5H	IDG10, 10H	IDG20, 20H	
7	Membrane module set	—	IDG-EL5 IDG-EL5H	IDG-EL10 IDG-EL10H	IDG-EL20 IDG-EL20H	
8	Dew point indicator set	—	—	IDG-DP01		
9		—	—	IDG-DP01-X001		With option: P

**IDG30, IDG30H, IDG30L
IDG50, IDG50H, IDG50L**

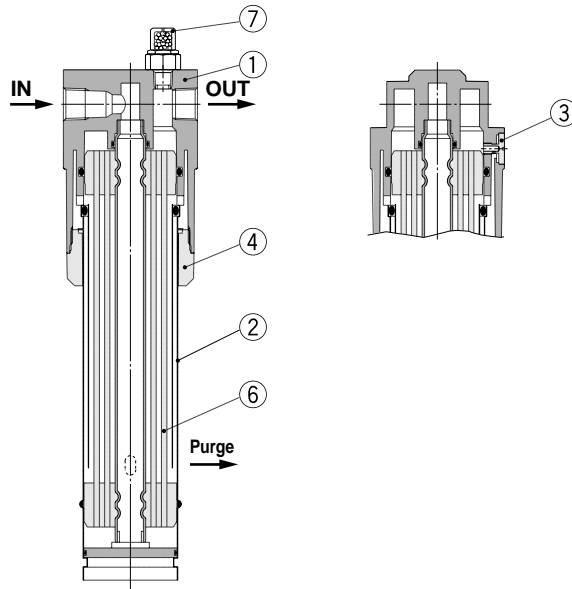

Optional specifications

With fitting for purge air discharge (Option: P)

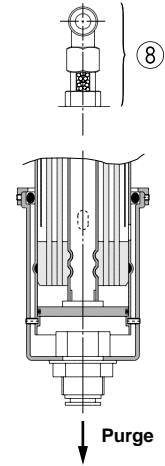

**IDG60, IDG60H, IDG60L
IDG75, IDG75H, IDG75L
IDG100, IDG100H, IDG100L**

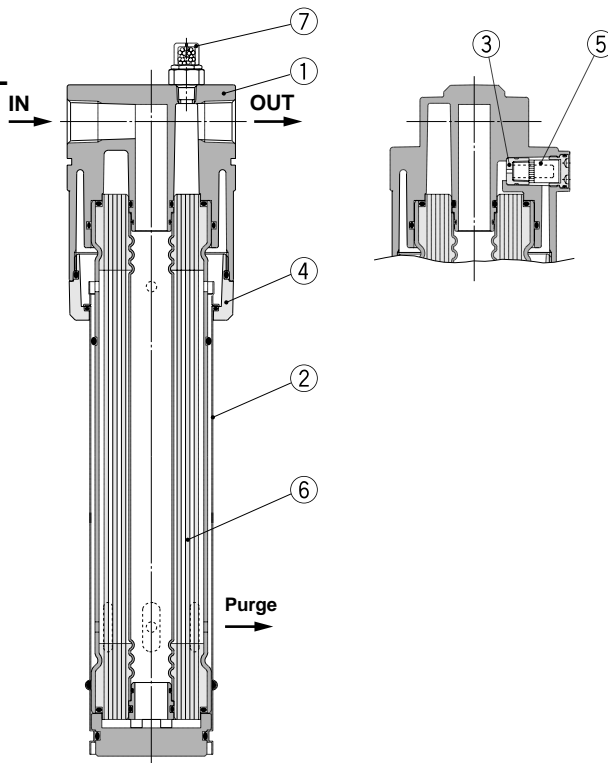

Optional specifications

With fitting for purge air discharge (Option: P)

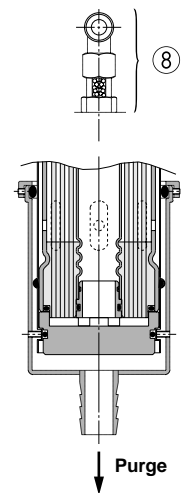

Parts list

No.	Description	Material					Note
		IDG30, 30H, 30L	IDG50, 50H, 50L	IDG60, 60H, 60L	IDG75, 75H, 75L	IDG100, 100H, 100L	
1	Body	Aluminum alloy					Platinum silver coating
2	Case	Stainless steel					
3	Orifice	Stainless steel					
4	Holder	Aluminum alloy		Aluminum			
5	Silencer	Resin + Copper alloy					

Replacement parts

No.	Description	Part Nos.					Note
		IDG30, 30H, 30L	IDG50, 50H, 50L	IDG60, 60H, 60L	IDG75, 75H, 75L	IDG100, 100H, 100L	
6	Membrane module set	IDG-EL30	IDG-EL50	IDG-EL60 IDG-EL60L	IDG-EL75 IDG-EL75L	IDG-EL100 IDG-EL100L	
7	Dew point indicator set	IDG-DP01					
8		IDG-DP01-X001					With option: P

Series IDG

Dimensions

IDG1

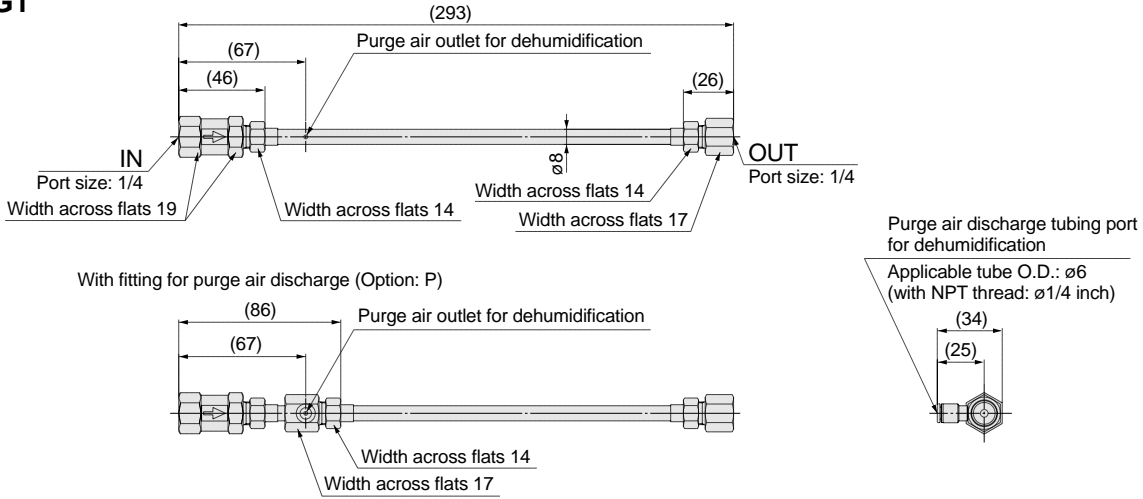

IDG5, IDG5H

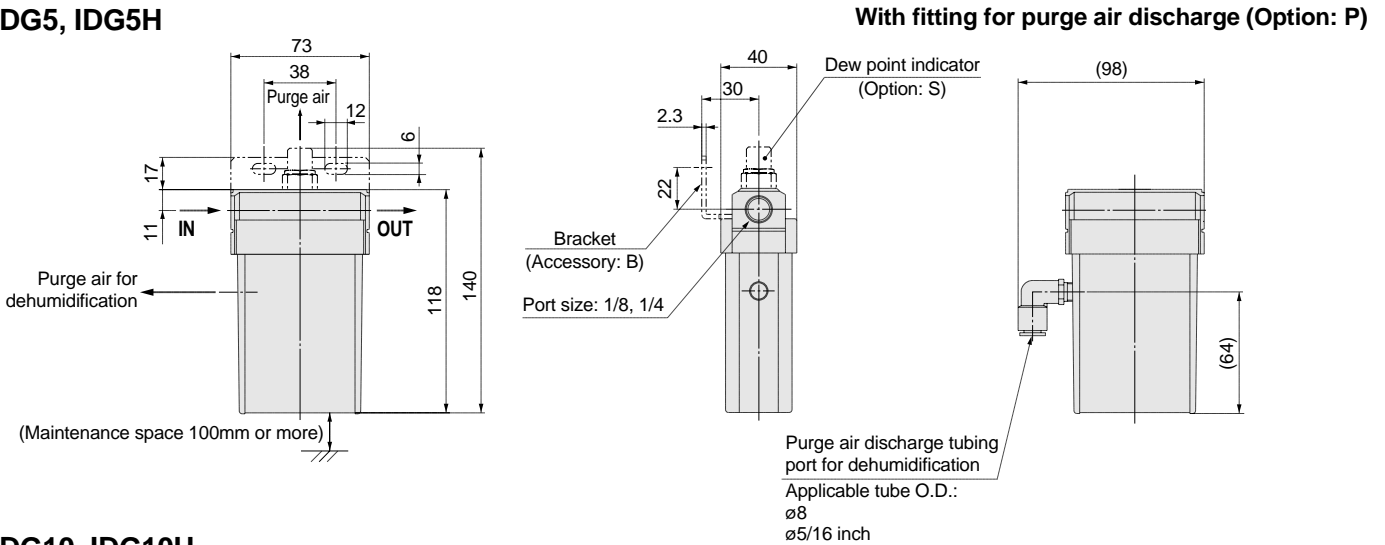

IDG10, IDG10H IDG20, IDG20H

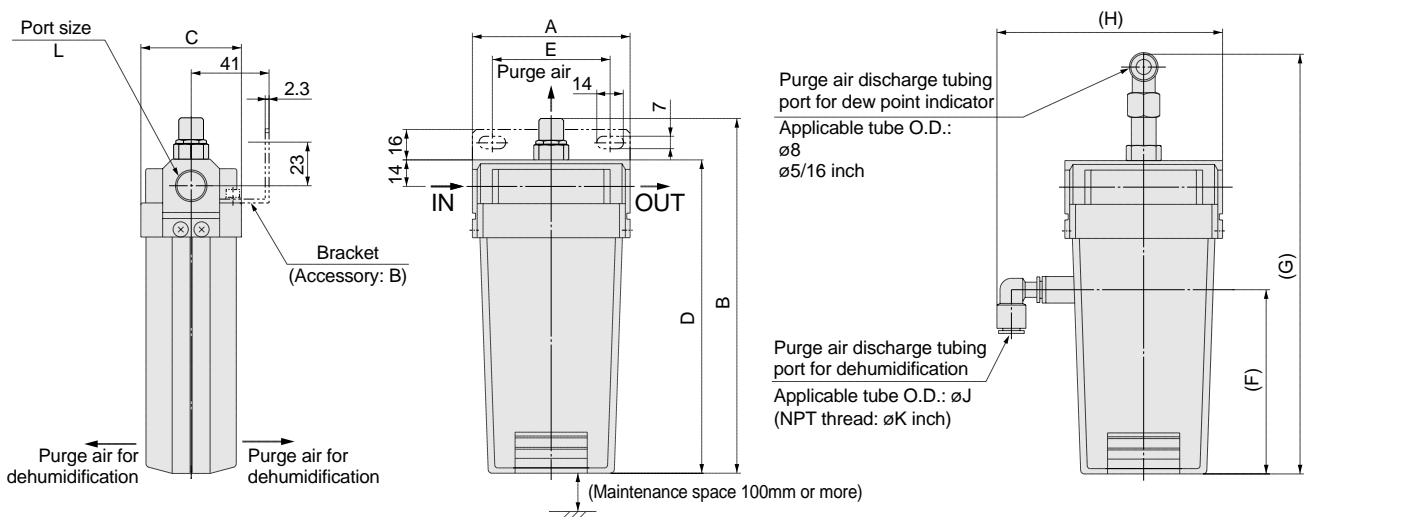

Models	Port size L	A	B	C	D	E	Option: P				
							F	G	H	J	K
IDG10, IDG10H	1/4, 3/8	83	187	53	165	62	97	224	119 [126]	8	5/16
IDG20, IDG20H	1/4, 3/8	113	212	54	190	82	114	249	147 [154]	10	3/8

Values inside [] are for NPT threads

IDG30, IDG30H, IDG30L IDG50, IDG50H, IDG50L

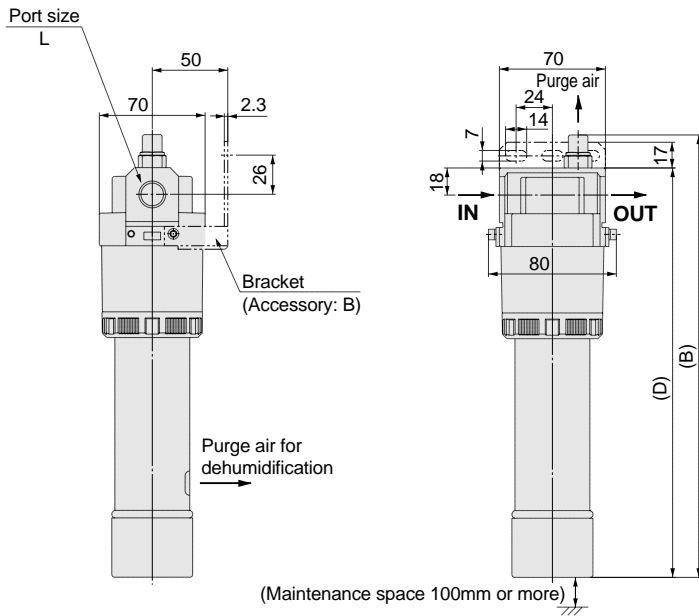

With fittings for purge air discharge (Option: P)

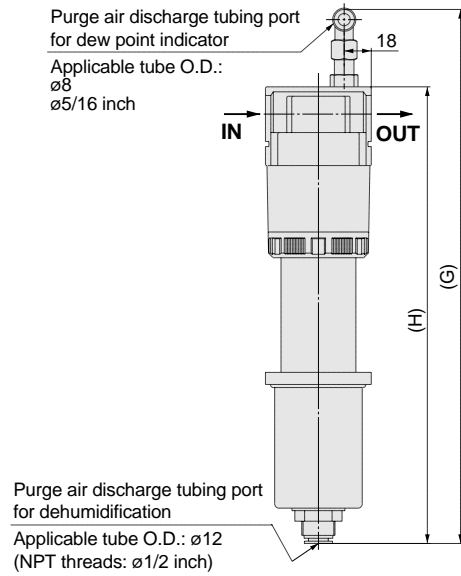

IDG60, IDG60H, IDG60L IDG75, IDG75H, IDG75L IDG100, IDG100H, IDG100L

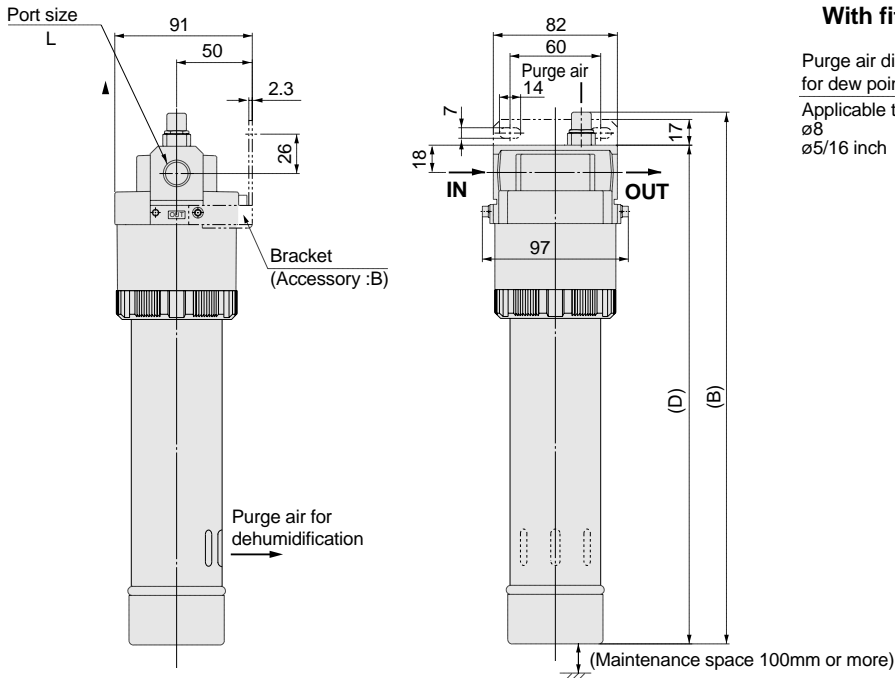

With fittings for purge air discharge (Option: P)

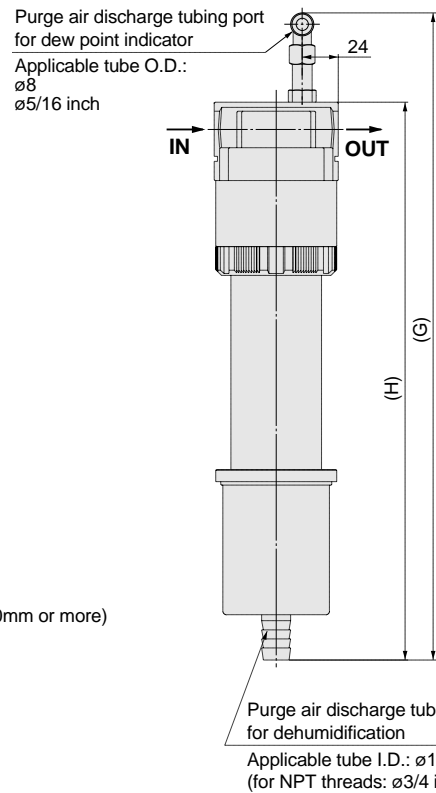

Models	Port size L	B	D	Option: P	
				G	H
IDG30, IDG30H, IDG30L	1/4, 3/8	293	271	361	302
IDG50, IDG50H, IDG50L		337	315	405	346
IDG60, IDG60H	3/8, 1/2	352	330	428	369
IDG75, IDG75H, IDG100, IDG100H	1/2	392	370	468	409
IDG60L	3/8, 1/2	472	450	548	489
IDG75L		542	520	618	559
IDG100L					

Membrane Air Dryer Unit

Air Dryer

Units (M Type, V Type)

How to Order

IDG 30 M 03

Size

5
10
20
30
50
60
75
100

Optional specifications

Symbol	Contents	Sizes							
		5	10	20	30	50	60	75	100
Nil	None (standard)	●	●	●	●	●	●	●	●
P	With fitting for purge air discharge	●	●	●	●	●	●	●	●
R	Flow direction (right→left)	●	●	●	●	●	●	●	●
S	With dew point indicator	●	Standard equipment						

Note) • In case of two or more options, indicate them in an alphabetical order.
• Symbol P is for M type only.

Standard dew point temperature and air flow rate

Symbol	Standard dew point °C	Flow rate by size							
		5	10	20	30	50	60	75	100
Nil	-20	50/12	100/25	200/50	300/75	500/125	600/125	750/150	1000/190
H	-15	50/6	100/11	200/22	300/35	500/60	600/65	750/80	1000/110
L	-40	—	—	—	75/25	110/40	170/57	240/80	300/100

Drain discharge method

(Mist separator, Micro mist separator, Micro mist separator with pre-filter)

Symbol	Drain discharge method	Sizes							
		5	10	20	30	50	60	75	100
Nil	Manual valve	●	●	●	●	●	●	●	●
C	N.C. auto drain	—	●	●	—	—	—	—	—
D	N.O. auto drain	●	—	—	●	●	●	●	●
J	Drain guide (bore 1/4 without valve mechanism)	—	●	●	●	●	●	●	●

Note) • A differential pressure type auto drain is used for body size 5.
• When symbols C or D are specified, an auto drain with a part number shown on page 13 is mounted.

Component equipment

Symbol	Contents	Description	Models				
			Mist separator	Micro mist separator	Micro mist separator with pre-filter	Membrane air dryer	Regulator
M	With separator	IDG5 to IDG50	●	●	—	●	—
		IDG5H to IDG50H	●	●	—	●	—
		IDG30L, IDG50L	●	●	—	●	—
		IDG60 to IDG100	—	—	●	●	—
		IDG60H to IDG100H	—	—	●	●	—
V	With regulator and separator	IDG5 to IDG50	●	●	—	●	●
		IDG5H to IDG50H	●	●	—	●	●
		IDG30L, IDG50L	●	●	—	●	●
		IDG60 to IDG100	—	—	●	●	●
		IDG60H to IDG100H	—	—	●	●	●
V	With regulator and separator	IDG60L to IDG100L	●	●	—	●	●
		IDG60L to IDG100L	●	●	—	●	●

Port size

Symbol	Bore	Sizes							
		5	10	20	30	50	60	75	100
01	1/8	●	—	—	—	—	—	—	—
02	1/4	●	●	●	●	—	—	—	—
03	3/8	—	●	●	●	●	●	Note)	Note)
04	1/2	—	—	—	—	—	●	●	●

Note) For standard dew point -40°C (symbol L) only

Thread type

Nil	Rc
N	NPT
F	G

Standard Specifications/Units (M Type, V Type) [Standard Dew Point – 20°C]

Models		Standard dew point –20°C							
		IDG5M	IDG10M	IDG20M	IDG30M	IDG50M	IDG60M	IDG75M	IDG100M
		IDG5V	IDG10V	IDG20V	IDG30V	IDG50V	IDG60V	IDG75V	IDG100V
Component equipment	Mist separator	AFM2000	AFM3000		AFM4000			—	
	Micro mist separator	AFD2000	AFD3000		AFD4000			—	
	Micro mist separator with pre-filter	—					AMH350	AMH450	
	Regulator (V type only)	AR2001	AR2501			AR4001			
Range of operating conditions	Fluid	Compressed air							
	Inlet air pressure MPa	0.3 to 0.85			0.3 to 1.0				
	Inlet air temperature	–5 to 55°C <small>Note1)</small>			–5 to 50°C <small>Note1)</small>			5 to 50°C	
	Ambient temperature	–5 to 55°C			–5 to 50°C			5 to 50°C	
Standard performance	Outlet air atmospheric pressure dew point	–20°C							
	Inlet air flow rate /min (ANR) <small>Note 2)</small>	62	125	250	375	625	725	900	1190
Standard performance conditions	Outlet air flow rate /min (ANR)	50	100	200	300	500	600	750	1000
	Purge air flow rate /min (ANR) <small>Note 3)</small>	12	25	50	75	125	125	150	190
	Inlet air pressure MPa	0.7							
	Inlet air temperature	25°C							
	Inlet air saturation temperature	25°C							
	Ambient temperature	25°C							
	Dew point indicator purge air flow rate	1 /min (ANR) {inlet air pressure at 0.7MPa}							
Micro mist separator filtration degree	0.01µm (95% filtered particle size)								
Micro mist separator with pre-filter filtration degree	0.01µm (95% filtered particle size)								
Regulator construction (V type only)	Relief type								
Port size (nominal size B)	1/8, 1/4	1/4, 3/8				3/8, 1/2	1/2		
Weight kg (with auto drain)	M type	0.83 (0.90)	1.21 (1.30)	1.44 (1.53)	2.23 (2.33)	2.26 (2.36)	2.55 (2.65)	3.10 (3.20)	3.15 (3.25)
	V type	1.28 (1.35)	1.67 (1.76)	1.90 (1.99)	3.34 (3.45)	3.37 (3.48)	3.74 (3.84)	4.29 (4.39)	4.34 (4.44)

Note 1) With no freezing.
 Note 2) ANR indicates the flow rate converted to the value for 20°C at atmospheric pressure.
 Note 3) Includes dew point indicator purge air flow rate 1 /min (ANR) (inlet air pressure at 0.7MPa) (except IDG5M and IDG5V).
 Note 4) Refer to CAT.E510-A "Modular Type Regulator with Built-in Pressure Gauge" for regulator flow rate characteristics and pressure characteristics.

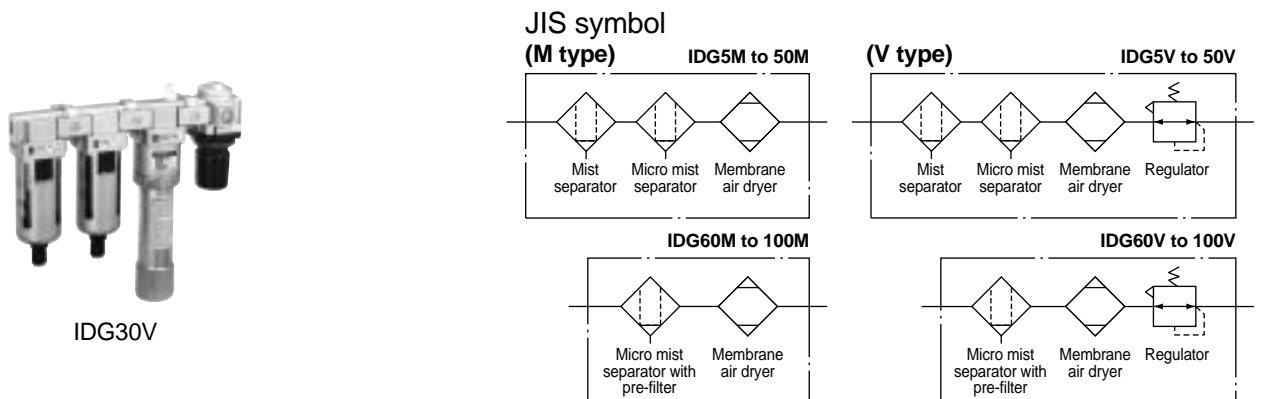

Part numbers/Auto drain, Case assembly, Pressure gauge

Applicable models		IDG5M	IDG10M	IDG20M	IDG30M	IDG50M	IDG60M	IDG75M	IDG100M
		IDG5V	IDG10V	IDG20V	IDG30V	IDG50V	IDG60V	IDG75V	IDG100V
Differential pressure type auto drain		AD62	—	—	—	—	—	—	—
Float type auto drain	N.C.	—	AD53			—	—	—	—
	N.O.	—	—	—	AD44		—	—	—
Case assembly (N.O.)		—	—	—	—	—	AMH-CA350-D	AMH-CA450-D	
Pressure gauge (V type only)		GC30-10							

Replacement parts (Mist separator, Micro mist separator, Element for micro mist separator with pre-filter)

Description	Model	AFM2000	AFD2000	AFM3000	AFD3000	AFM4000	AFD4000	AMH350	AMH450
Element assembly		630611	63092	630617	63093	630623	63094	AMH-EL350	AMH-EL450

Refer to pages 8 and 9 for membrane air dryer replacement parts.

Series IDG

Standard Specifications/Units (M type, V type) [Standard dew point – 15°C]

Models		Standard dew point –15°C							
		IDG5HM	IDG10HM	IDG20HM	IDG30HM	IDG50HM	IDG60HM	IDG75HM	IDG100HM
		IDG5HV	IDG10HV	IDG20HV	IDG30HV	IDG50HV	IDG60HV	IDG75HV	IDG100HV
Component equipment	Mist separator	AFM2000	AFM3000		AFM4000			—	
	Micro mist separator	AFD2000	AFD3000		AFD4000			—	
	Micro mist separator with pre-filter	—					AMH350	AMH450	
	Regulator (V type only)	AR2001	AR2501			AR4001			
Range of operating conditions	Fluid	Compressed air							
	Inlet air pressure MPa	0.3 to 0.85			0.3 to 1.0				
	Inlet air temperature	– 5 to 55°C ^{Note 1)}			– 5 to 50°C ^{Note 1)}			5 to 50°C	
	Ambient temperature	– 5 to 55°C			– 5 to 50°C			5 to 50°C	
Standard performance	Outlet air atmospheric pressure dew point	– 15°C							
Standard performance conditions	Inlet air flow rate /min (ANR) ^{Note 2)}	56	111	222	335	560	665	830	1110
	Outlet air flow rate /min (ANR)	50	100	200	300	500	600	750	1000
	Purge air flow rate /min (ANR) ^{Note 3)}	6	11	22	35	60	65	80	110
	Inlet air pressure MPa	0.7							
	Inlet air temperature	25°C							
	Inlet air saturation temperature	25°C							
	Ambient temperature	25°C							
Dew point indicator purge air flow rate		1 /min (ANR) {inlet air pressure at 0.7MPa}							
Micro mist separator filtration degree		0.01µm (95% filtered particle size)							
Micro mist separator with pre-filter filtration degree		0.01µm (95% filtered particle size)							
Regulator construction (V type only)		Relief type							
Port size (nominal size B)		1/8, 1/4	1/4, 3/8			3/8, 1/2	1/2		
Weight kg (with auto drain)	M type	0.83 (0.90)	1.21 (1.30)	1.44 (1.53)	2.23 (2.33)	2.26 (2.36)	2.55 (2.65)	3.10 (3.20)	3.15 (3.25)
	V type	1.28 (1.35)	1.67 (1.76)	1.90 (1.99)	3.34 (3.45)	3.37 (3.48)	3.74 (3.84)	4.29 (4.39)	4.34 (4.44)

Note 1) With no freezing.

Note 2) ANR indicates the flow rate converted to the value for 20°C at atmospheric pressure.

Note 3) Includes dew point indicator purge air flow rate 1 /min (ANR) (inlet air pressure at 0.7MPa) (except IDG5HM and IDG5HV).

Note 4) Refer to CAT.E510-A "Modular Type Regulator with Built-in Pressure Gauge" for regulator flow rate characteristics and pressure characteristics.



IDG30HV

JIS symbol

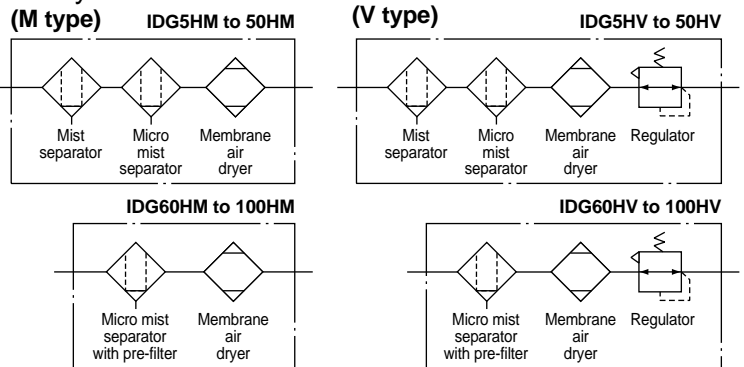

Part numbers/Auto drain, Case assembly, Pressure gauge

Applicable models		IDG5HM	IDG10HM	IDG20HM	IDG30HM	IDG50HM	IDG60HM	IDG75HM	IDG100HM
Description		IDG5HV	IDG10HV	IDG20HV	IDG30HV	IDG50HV	IDG60HV	IDG75HV	IDG100HV
Differential pressure type auto drain		AD62	—	—	—	—	—	—	—
Float type auto drain	N.C.	—	AD53			—	—	—	—
	N.O.	—	—	—	AD44		—	—	—
Case assembly		—	—	—	—	—	AMH-CA350-D	AMH-CA450-D	
Pressure gauge (V type only)		GC30-10							

Replacement parts (Mist separator, Micro mist separator, Element for micro mist separator with pre-filter)

Description	Equipment	AFM2000	AFD2000	AFM3000	AFD3000	AFM4000	AFD4000	AMH350	AMH450
Element assembly		630611	63092	630617	63093	630623	63094	AMH-EL350	AMH-EL450

Refer to pages 8 and 9 for membrane air dryer replacement parts.

Standard Specifications/Units (M type, V type) [Standard Dew Point – 40°C]

Models		Standard dew point – 40°C				
		IDG30LM IDG30LV	IDG50LM IDG50LV	IDG60LM IDG60LV	IDG75LM IDG75LV	IDG100LM IDG100LV
Component equipment	Mist separator	AFM4000				
	Micro mist separator	AFD4000				
	Regulator (V type only)	AR4001				
Range of operating conditions	Fluid	Compressed air				
	Inlet air pressure MPa	0.3 to 1.0				
	Inlet air temperature ^{Note 1)}	– 5 to 50°C				
	Ambient temperature	– 5 to 50°C				
Standard performance	Outlet air atmospheric pressure dew point	– 40 (– 50)°C ^{Note 4)}				
Standard performance conditions	Inlet air flow rate /min (ANR) ^{Note 2)}	100	150	227	320	400
	Outlet air flow rate /min (ANR)	75	110	170	240	300
	Purge air flow rate /min (ANR) ^{Note 3)}	25	40	57	80	100
	Inlet air pressure MPa	0.7				
	Inlet air temperature	25°C				
	Inlet air saturation temperature	25°C				
	Ambient temperature	25°C				
Dew point indicator purge air flow rate		1 /min (ANR) (inlet air pressure at 0.7MPa)				
Micro mist separator filtration degree		0.01µm (95% filtered particle size)				
Regulator construction (V type only)		Relief type				
Port size (nominal size B)		1/4, 3/8			3/8, 1/2	
Weight kg (with auto drain)	M type	2.23 (2.33)	2.26 (2.36)	2.99 (3.09)	3.14 (3.24)	3.29 (3.39)
	V type	3.34 (3.45)	3.37 (3.48)	4.10 (4.20)	4.25 (4.35)	4.40 (4.50)

Note 1) With no freezing.

Note 2) ANR indicates the flow rate converted to the value for 20°C at atmospheric pressure.

Note 3) Includes dew point indicator purge air flow rate 1 /min (ANR) (inlet air pressure at 0.7MPa).

Note 4) Values inside () are applicable when a refrigeration type air dryer is installed on the upstream side.

Note 5) Refer to CAT.E510-A "Modular Type Regulator with Built-in Pressure Gauge" for regulator flow rate characteristics and pressure characteristics.



IDG30LV

JIS symbol (M type)

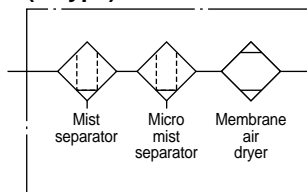

(V type)

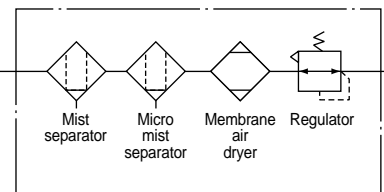

Part numbers/Auto drain, Pressure gauge

Applicable models	IDG30LM IDG30LV	IDG50LM IDG50LV	IDG60LM IDG60LV	IDG75LM IDG75LV	IDG100LM IDG100LV
Description					
Float type auto drain (N.O.)	AD44				
Pressure gauge	GC30-10				

Replacement parts (Mist separator, Micro mist separator element)

Description	Equipment	AFM4000	AFD4000
Element assembly		630623	63094

Refer to pages 8 and 9 for membrane air dryer replacement parts.

Flow Rate Characteristics

IDG5M, IDG5HM
IDG5V, IDG5HV

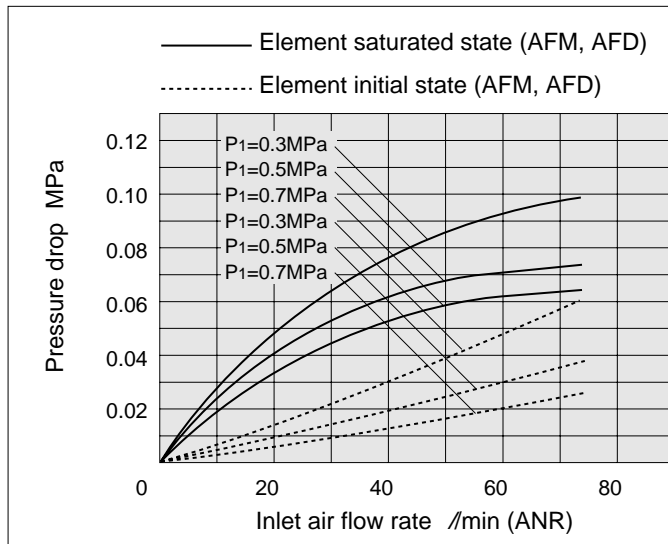

IDG10M, IDG10HM
IDG10V, IDG10HV

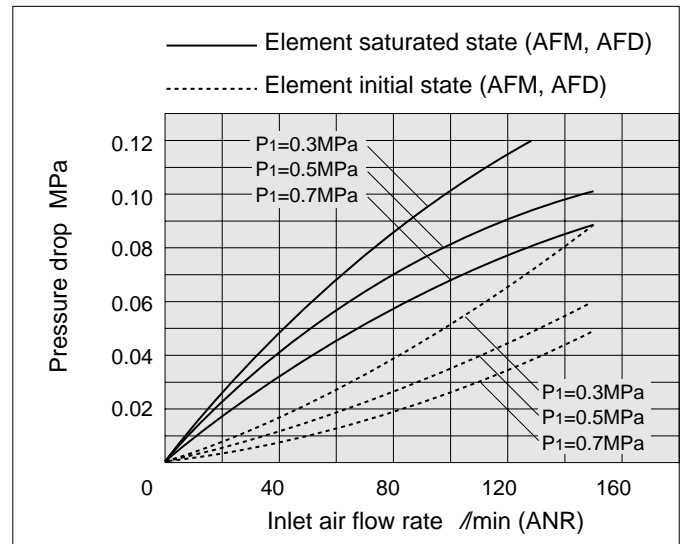

IDG20M, IDG20HM
IDG20V, IDG20HV

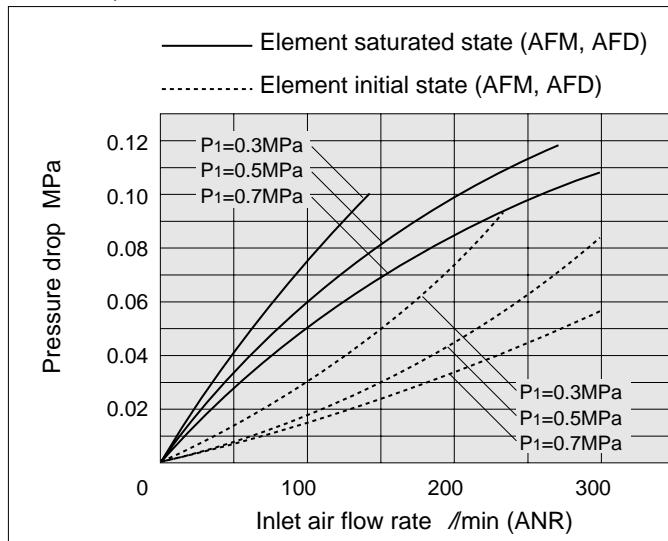

IDG30M, IDG30HM, IDG30LM
IDG30V, IDG30HV, IDG30LV

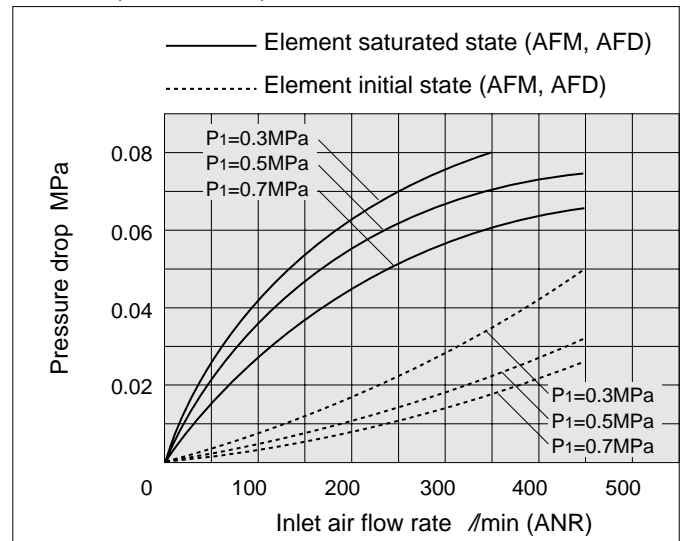

IDG50M, IDG50HM, IDG50LM
IDG50V, IDG50HV, IDG50LV

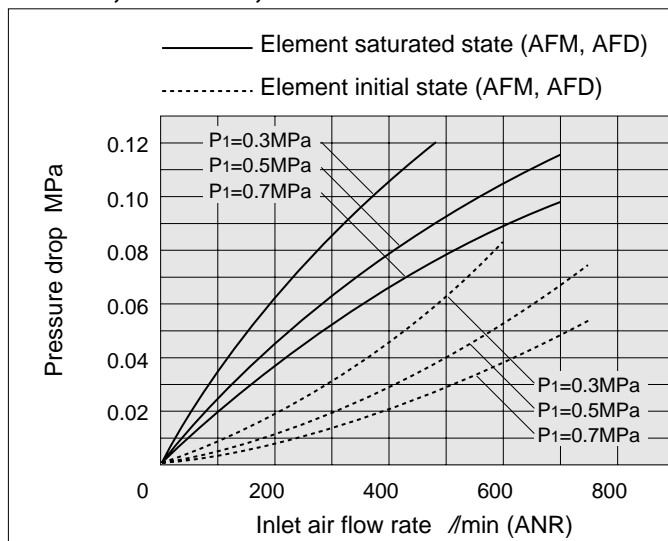

Conditions: Inlet air temperature 25°C, P₁: Inlet air pressure

IDG60M, IDG60HM IDG60V, IDG60HV

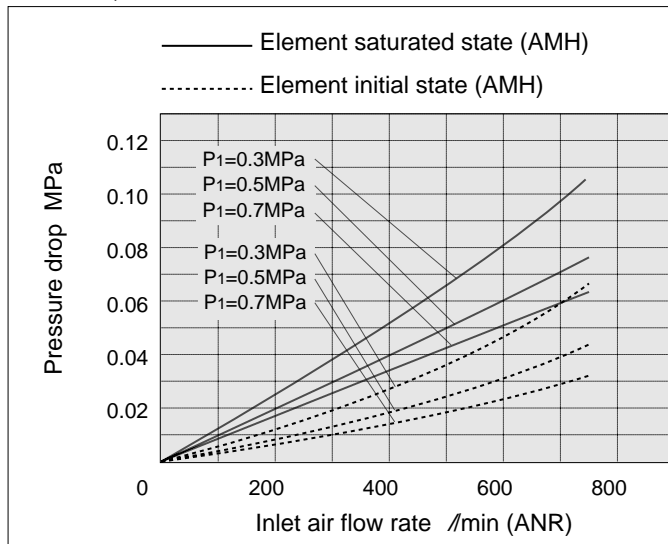

IDG60LM IDG60LV

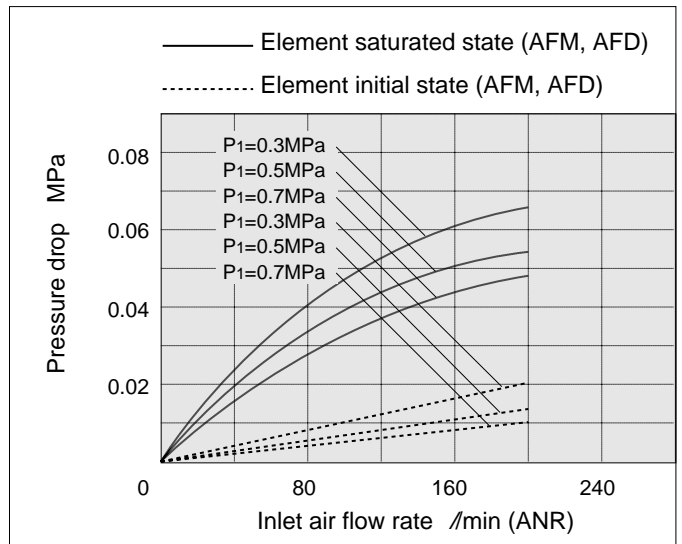

IDG75M, IDG75HM IDG75V, IDG75HV

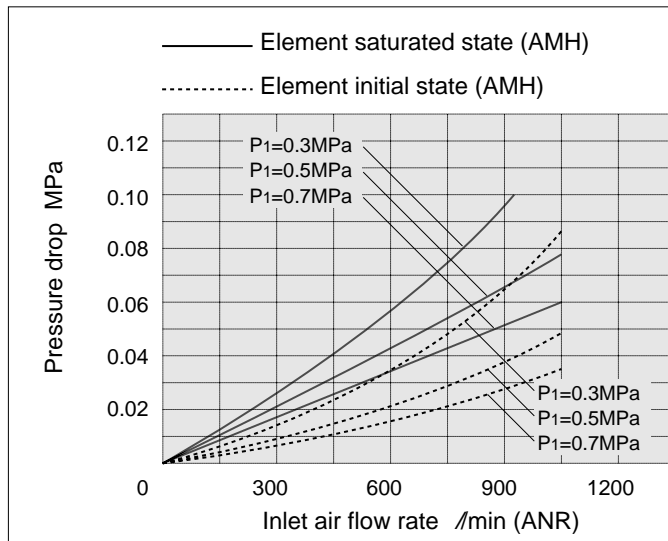

IDG75LM IDG75LV

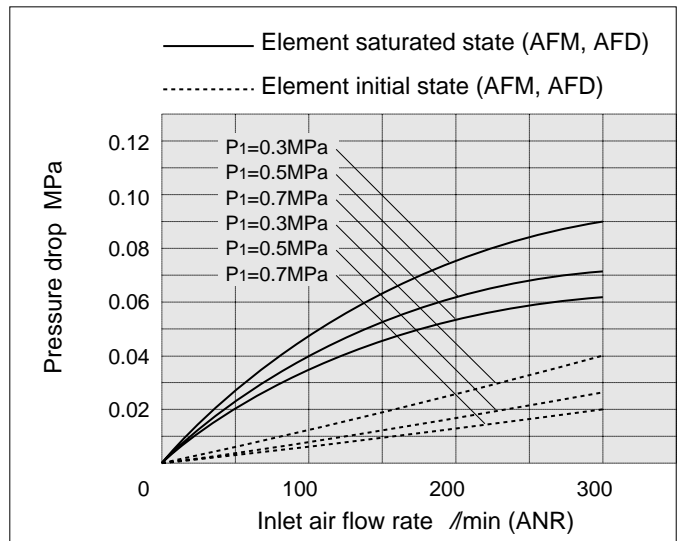

IDG100M, IDG100HM IDG100V, IDG100HV

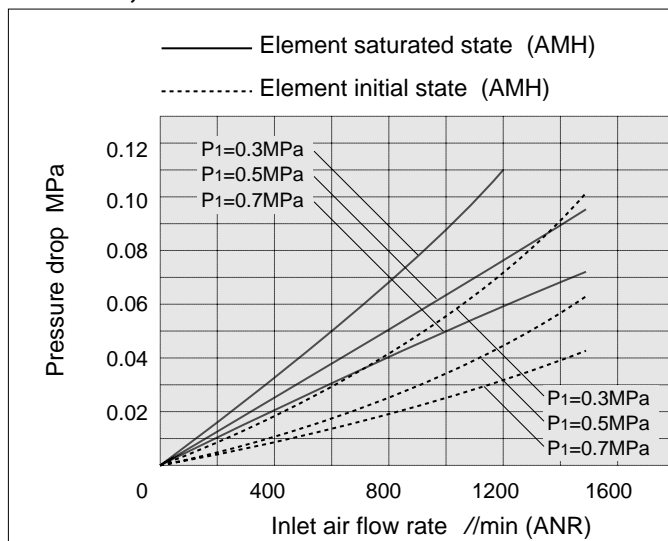

IDG100LM IDG100LV

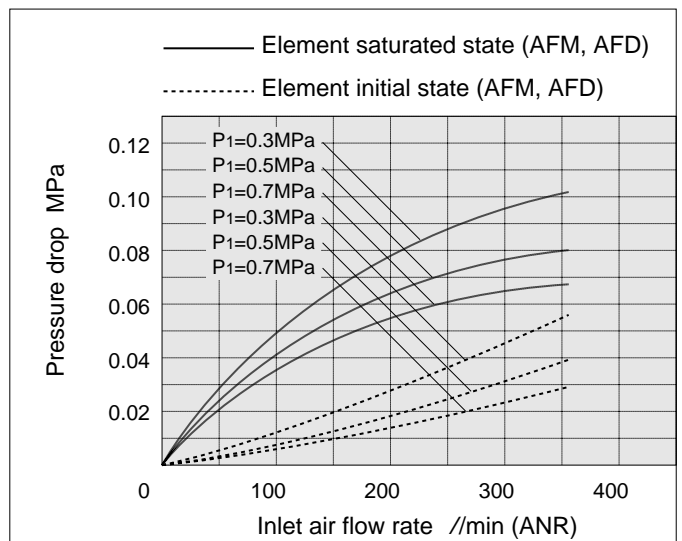

Series IDG

Dimensions (M Type)

IDG5M, IDG5HM

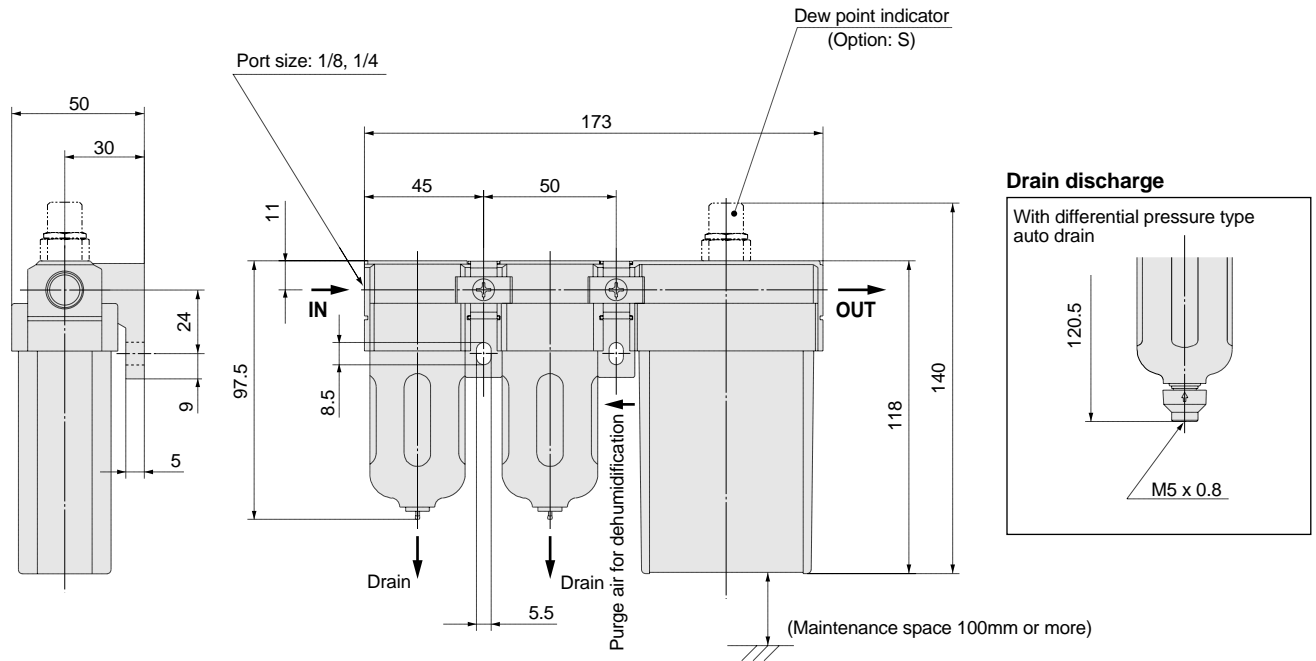

With fittings for purge air discharge (Option:P)

Purge air discharge tubing port for dew point indicator
Applicable tube O.D.: $\varnothing 8$

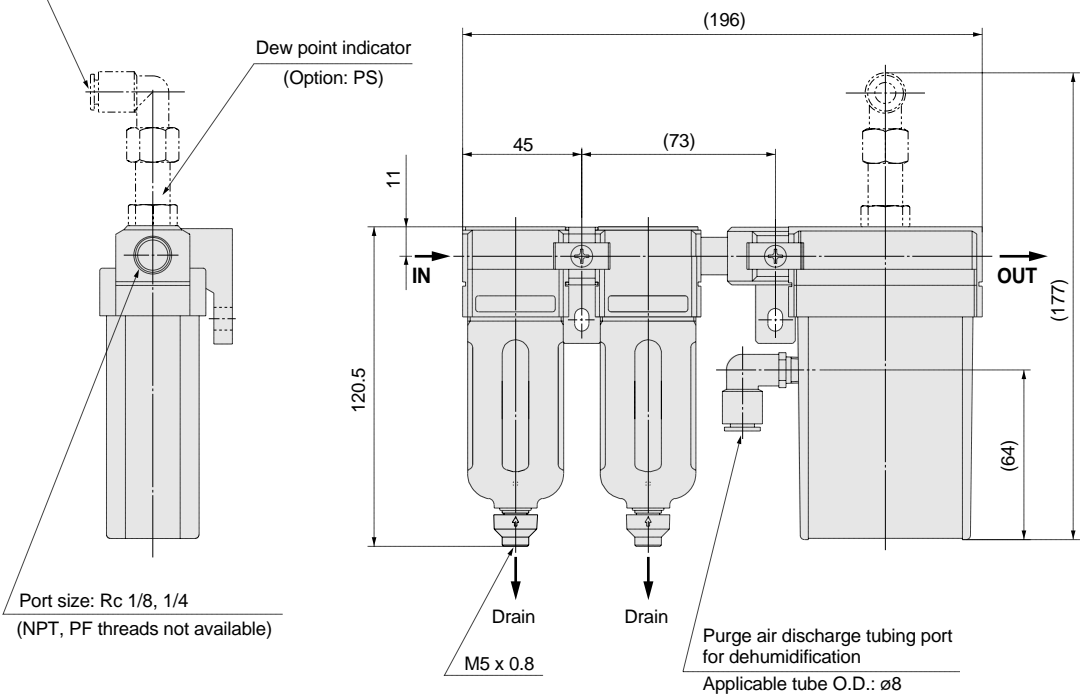

IDG10M, IDG10HM IDG20M, IDG20HM

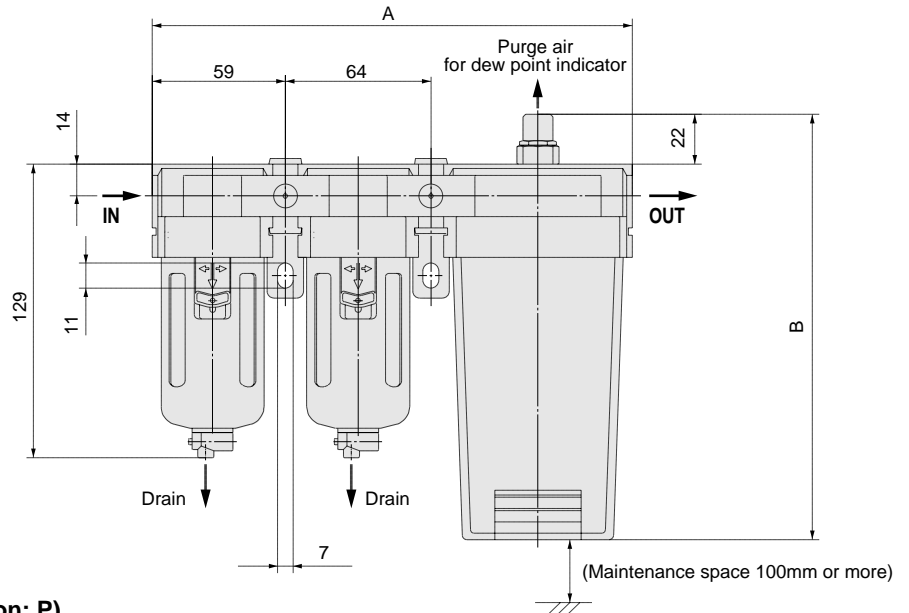
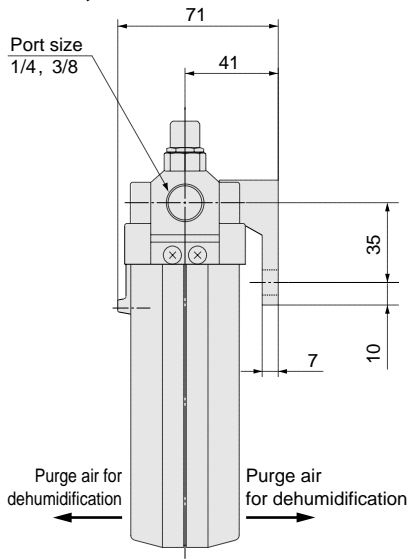

With fittings for purge air discharge (Option: P)

Drain discharge

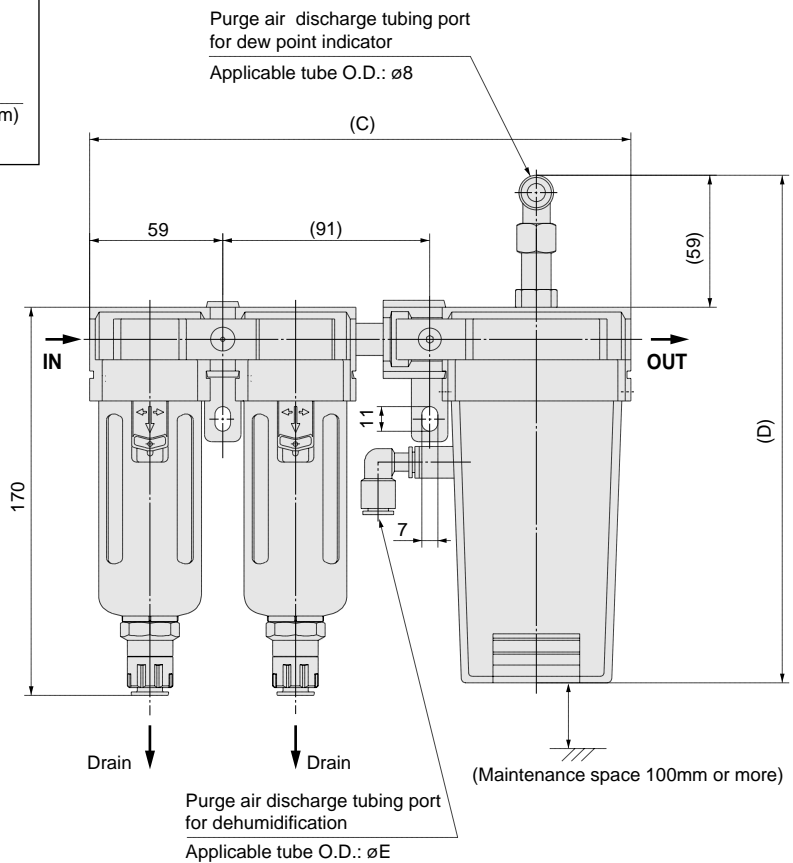
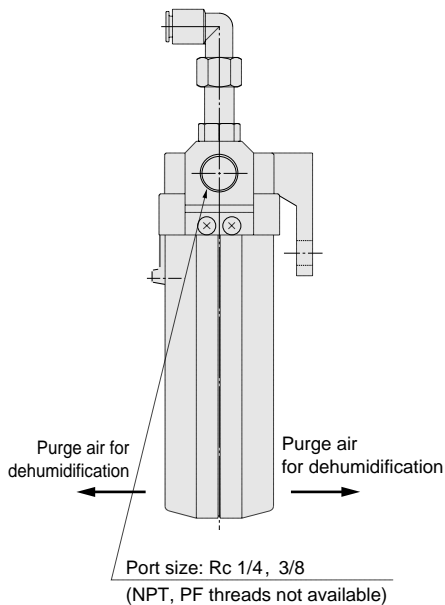
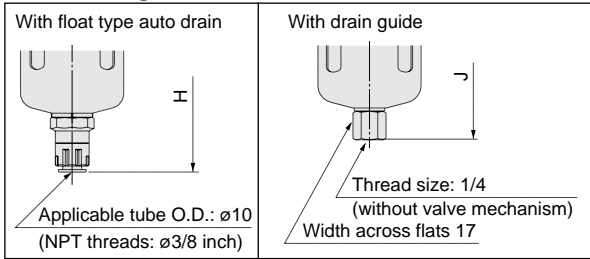

Drain discharge

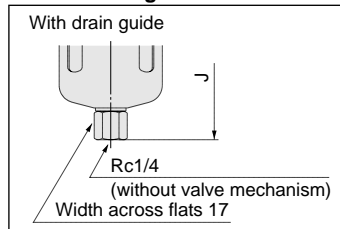

Models	A	B	Option: P			With float type auto drain	With drain guide
			C	D	E	H	J
IDG10M, IDG10HM	211	187	238	224	8	170	135
IDG20M, IDG20HM	241	212	268	249	10		

Series IDG

Dimensions (M Type)

IDG30M, IDG30HM, IDG30LM
IDG50M, IDG50HM, IDG50LM

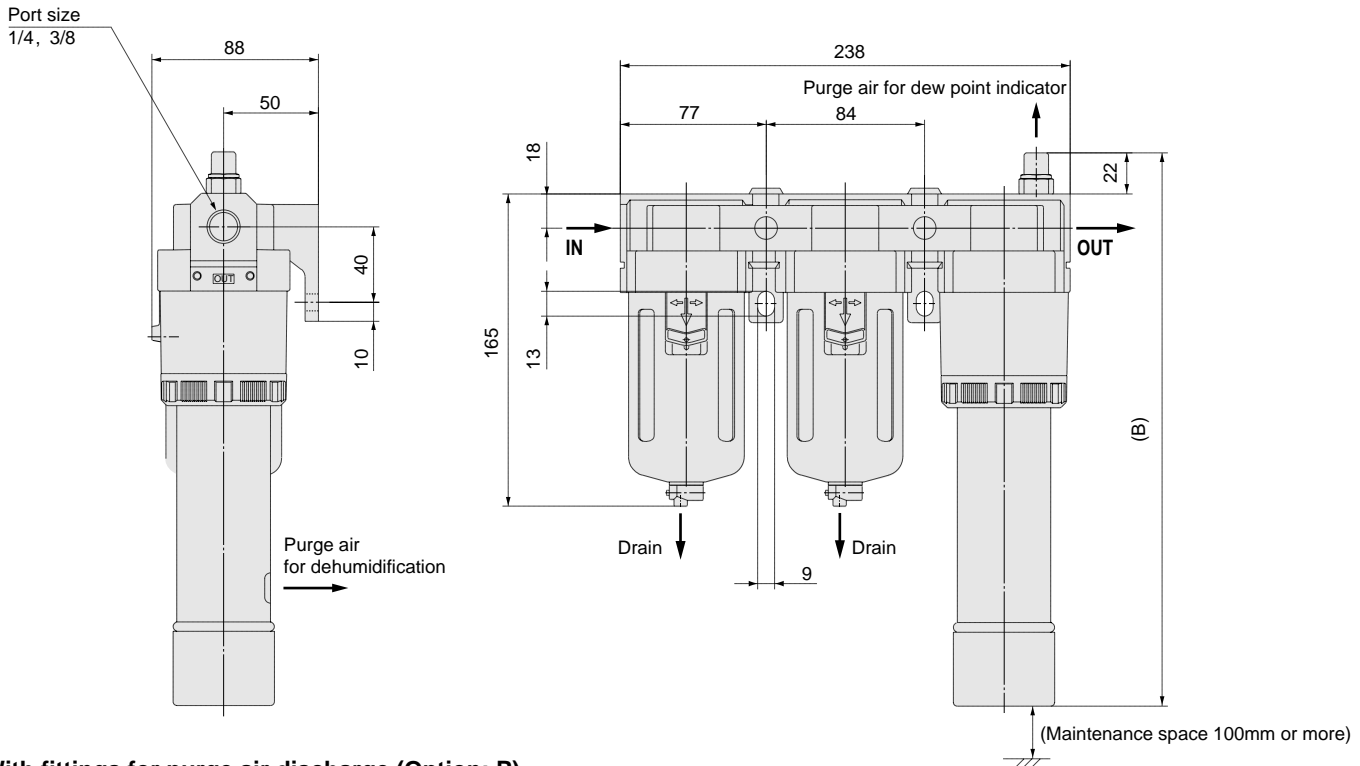

With fittings for purge air discharge (Option: P)

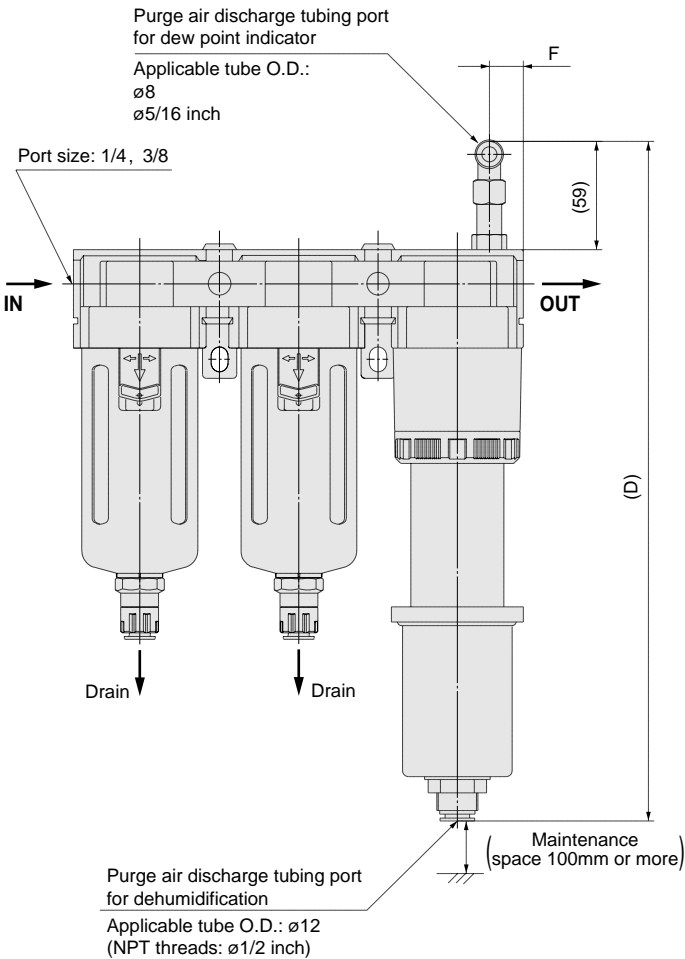

Models	B	Option: P		With float type auto drain	With drain guide
		D	F	H	J
IDG30M, IDG30HM, IDG30LM	293	361	18	206	171
IDG50M, IDG50HM, IDG50LM	337	405			

Drain discharge

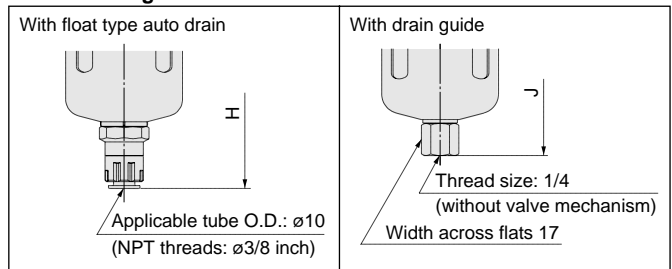

IDG60M, IDG60HM
IDG75M, IDG75HM
IDG100M, IDG100HM

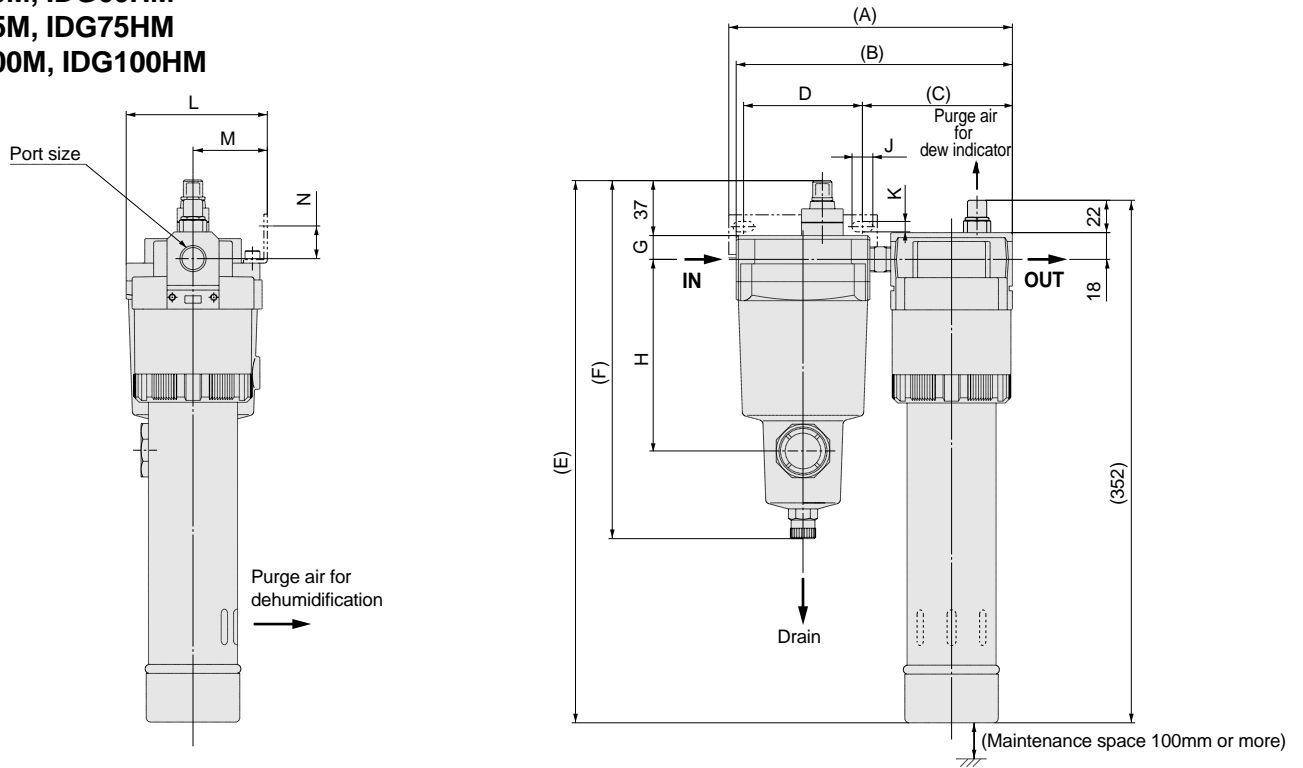

With fittings for purge air discharge (Option: P)

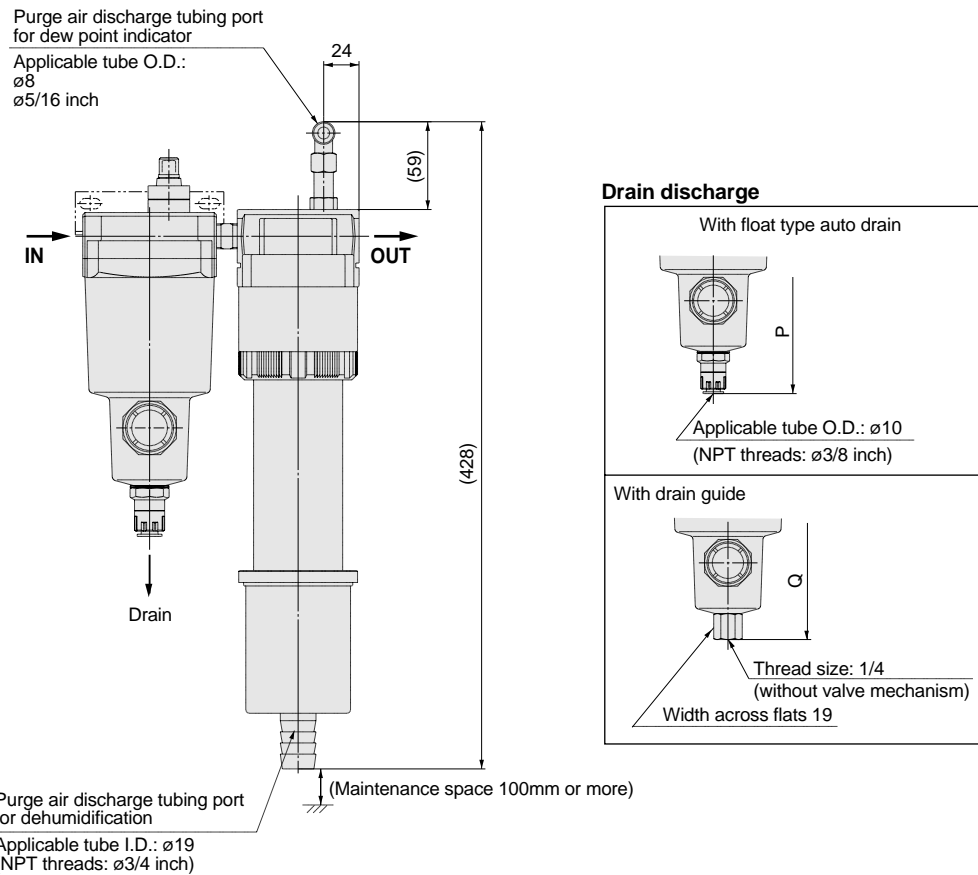

Models	Port size	A	B	C	D	E	F	G	H	J	K	L	M	N	With float type auto drain	With drain guide
															P	Q
IDG60M, IDG60HM	3/8, 1/2	191	186	101	80	365	241	16	129	14	7	95	50	22	255	241
IDG75M, IDG75HM, IDG100M, IDG100HM	1/2	204	202	104	90	368	262	19	147		9	108	55	25	276	262

Series IDG

Dimensions (M Type)

IDG60LM
IDG75LM
IDG100LM

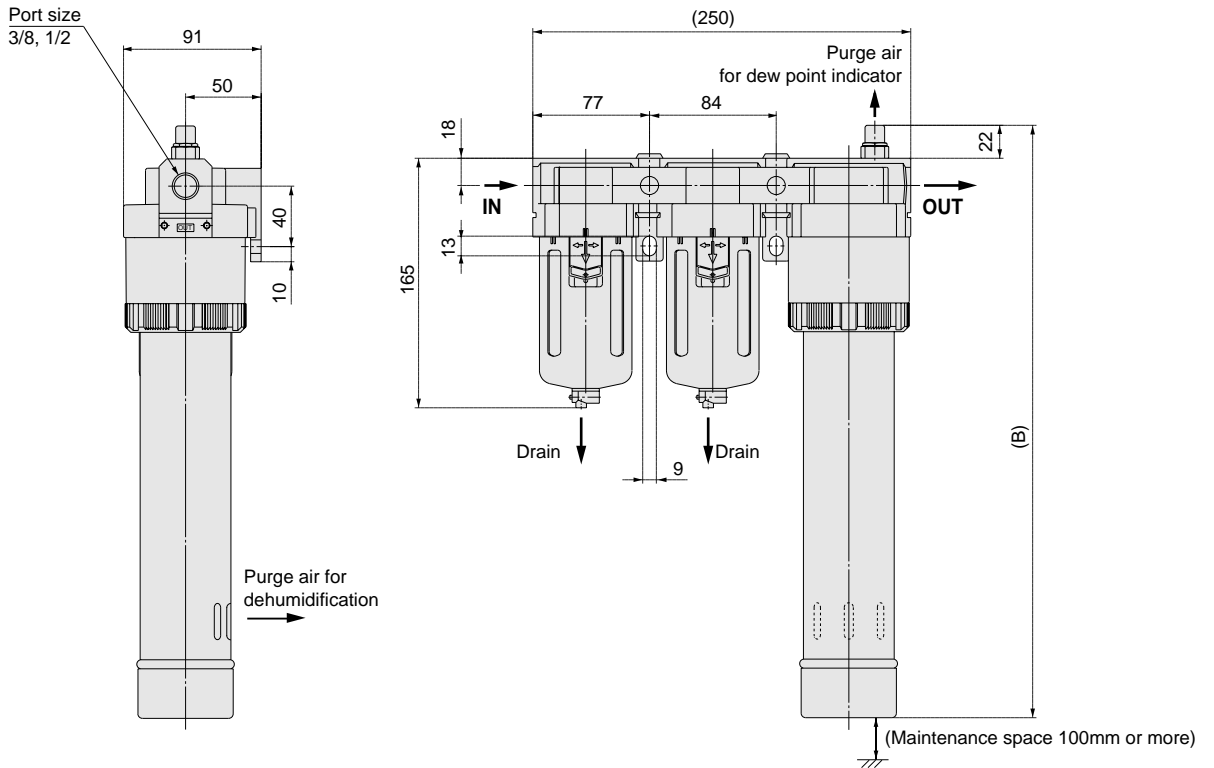

With fittings for purge air discharge (Option: P)

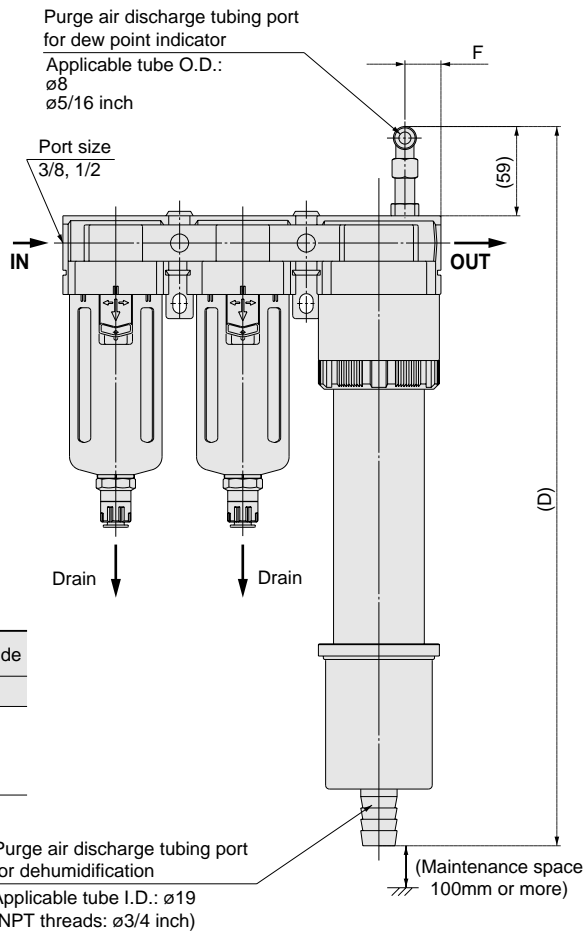
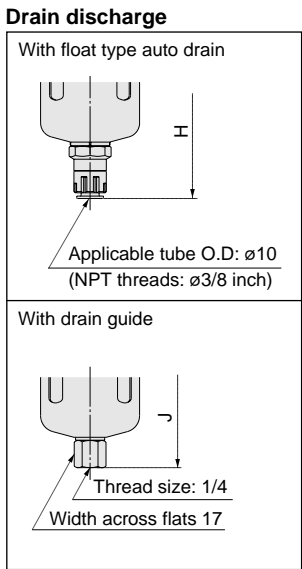

Model	B	Option: P		With float type auto drain	With drain guide
		D	F	H	J
IDG60LM	392	468	24	206	171
IDG75LM	472	548			
IDG100LM	542	618			

Dimensions (V Type)

IDG5V, IDG5HV

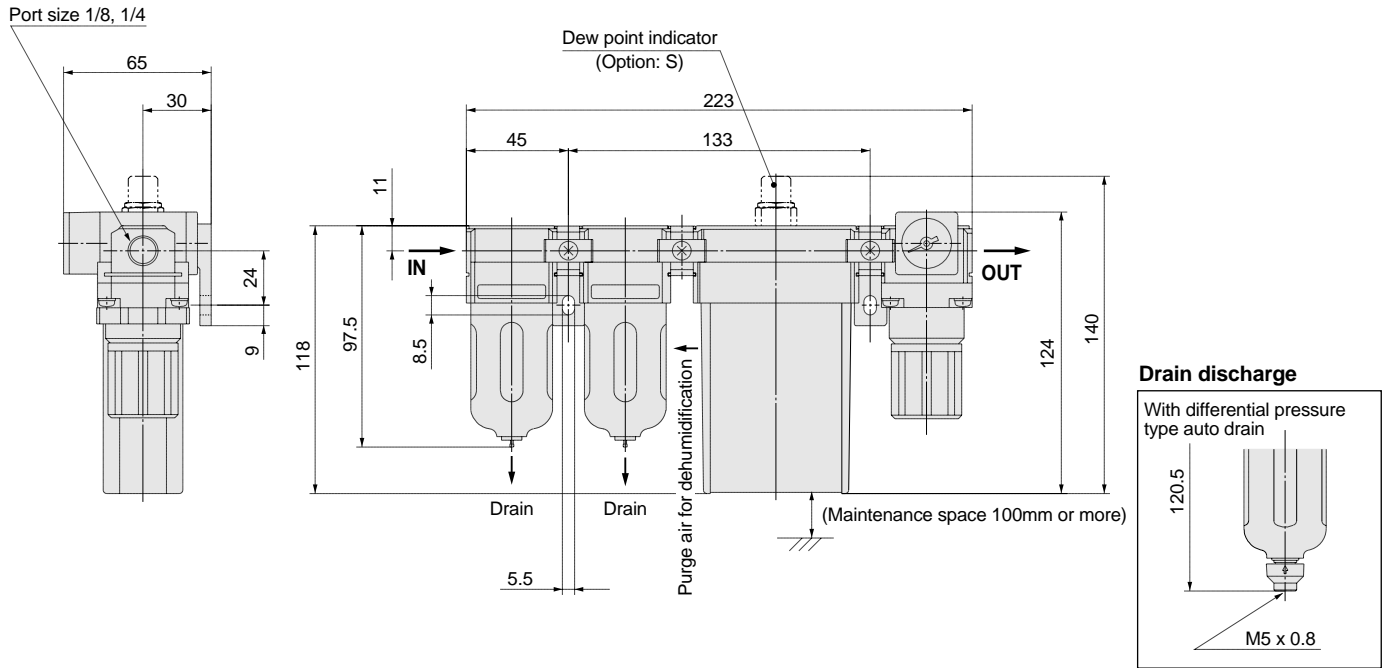

**IDG10V, IDG10HV
IDG20V, IDG20HV**

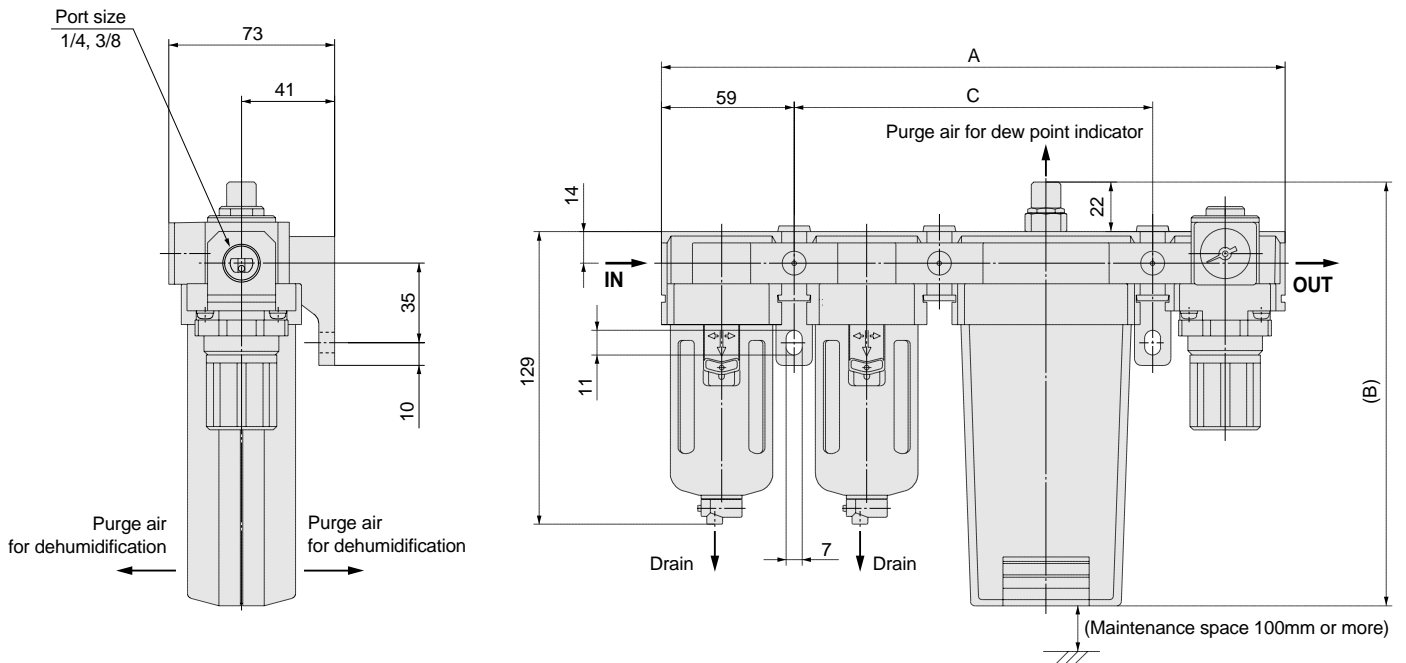

Drain discharge

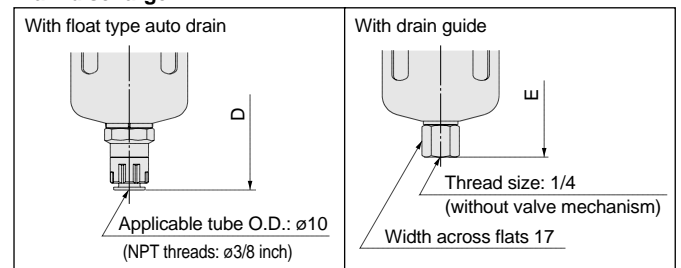

Models	A	B	C	With float type auto drain	With drain guide
				D	E
IDG10V, IDG10HV	275	187	158	170	135
IDG20V, IDG20HV	305	212	188		

Series IDG

Dimensions (V Type)

IDG30V, IDG30HV, IDG30LV
IDG50V, IDG50HV, IDG50LV

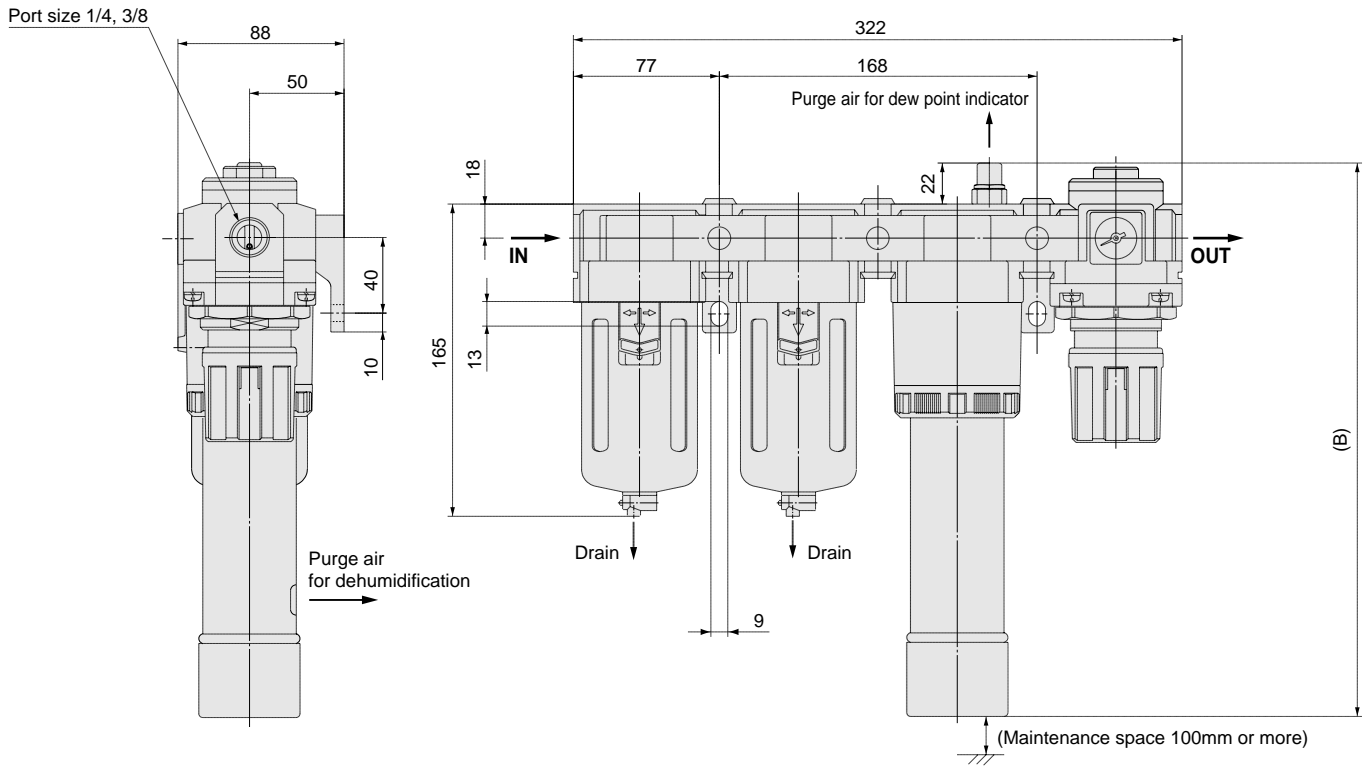

Models	B	With float type auto drain	With drain guide
		D	E
IDG30V, IDG30HV, IDG30LV	293	206	171
IDG50V, IDG50HV, IDG50LV	337		

Drain discharge

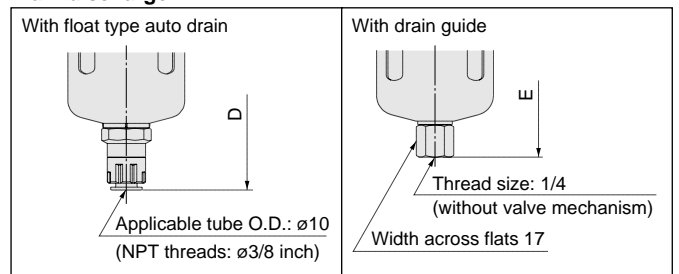

IDG60V, IDG60HV
IDG75V, IDG75HV
IDG100V, IDG100HV

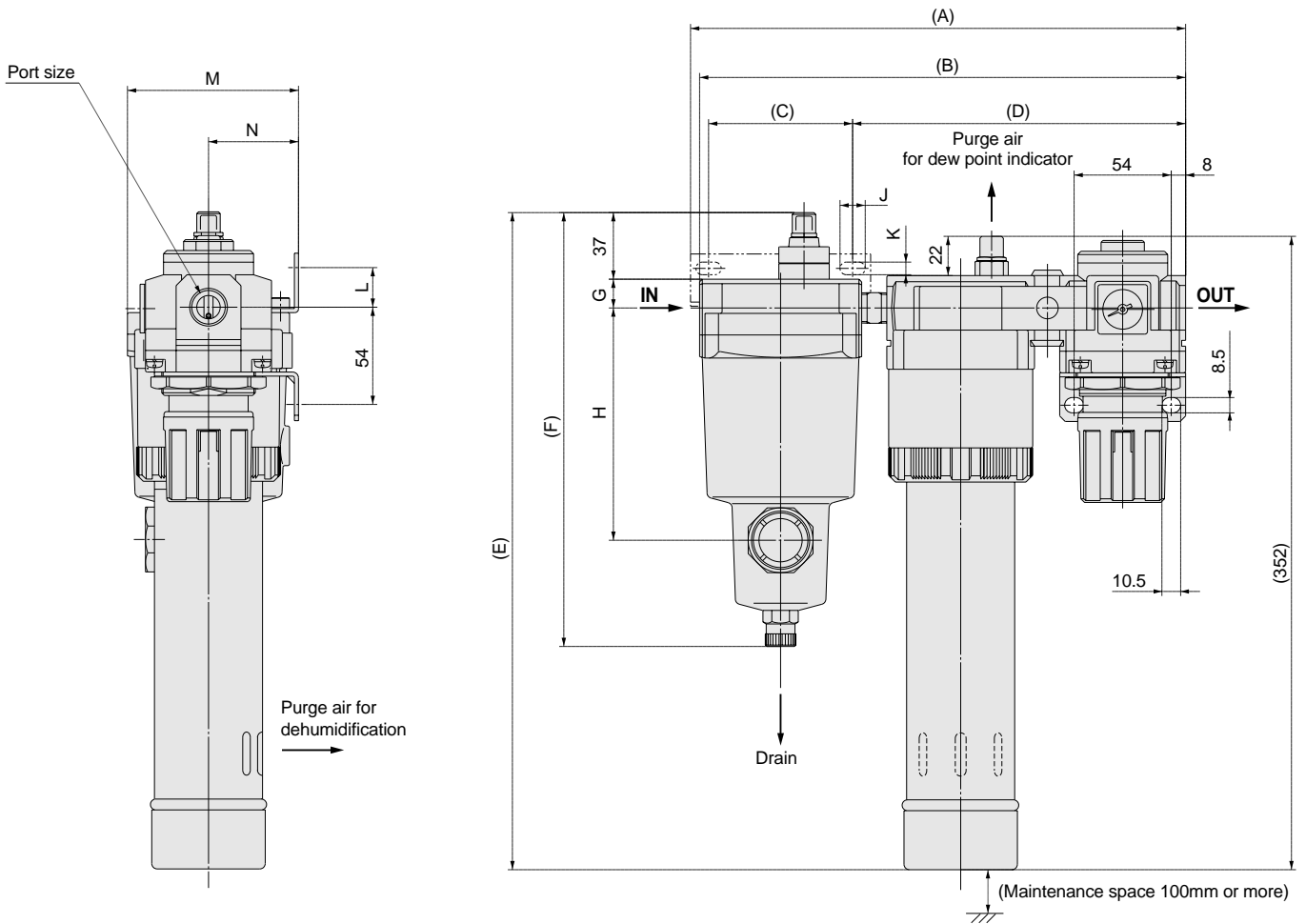

Drain discharge

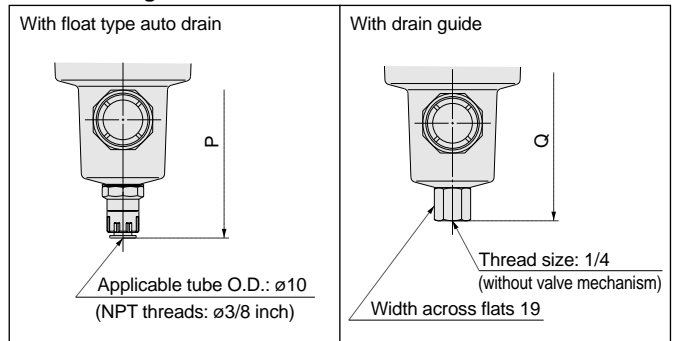

Models	Port size	A	B	C	D	E	F	G	H	J	K	L	M	N	With float type auto drain	With drain guide
															P	Q
IDG60V, IDG60HV	3/8, 1/2	275	270	80	185	365	241	16	129	14	7	22	95	50	255	241
IDG75V, IDG75HV, IDG100V, IDG100HV	1/2	288	286	90	188	368	262	19	147		9	25	108	55	276	262

Series IDG

Dimensions (V Type)

IDG60LV
IDG75LV
IDG100LV

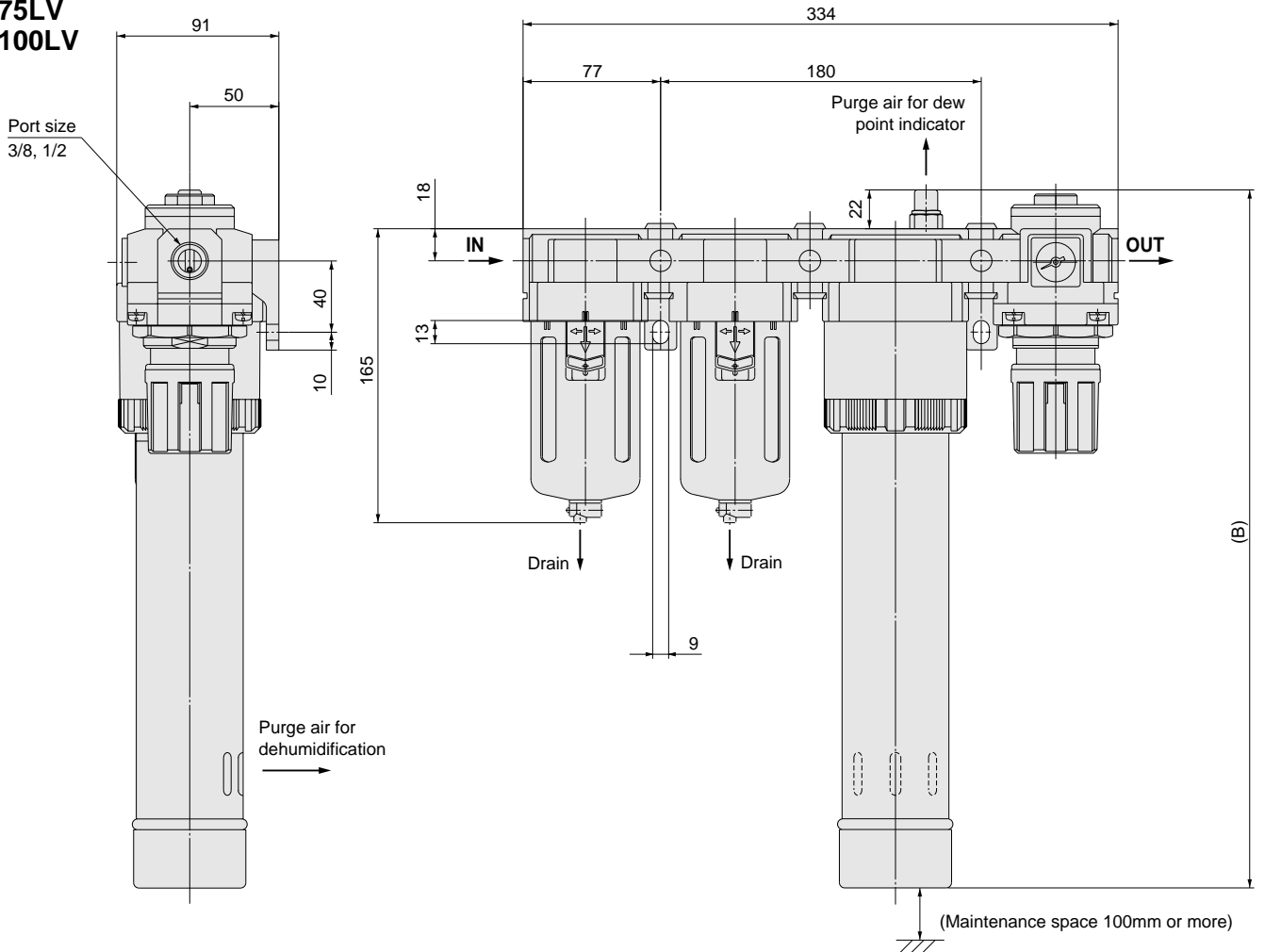

Model	B	With float type auto drain	With drain guide
		H	J
IDG60LV	392	206	171
IDG75LV	472		
IDG100LV	542		

Drain discharge

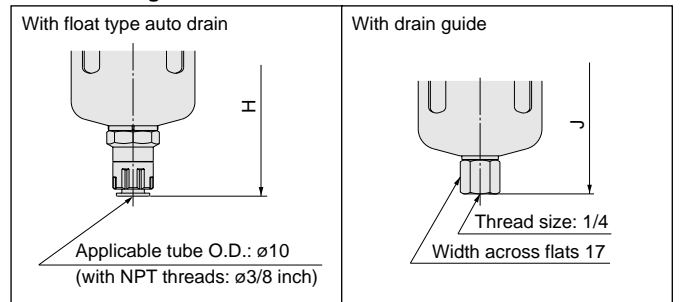

Series IDG Model Selection Method

Model Selection

Step 1 Confirmation of operating conditions

Outlet air flow rate [l/min (ANR)]
Outlet air atmospheric pressure dew point [°C]
(When necessary to convert from the dew point under pressure, refer to the dew point temperature conversion chart below.)
Inlet air pressure [MPa]
Inlet air temperature [°C]
Allowable pressure drop ΔP [MPa]
Compressed air supply capacity Q [l/min (ANR)]

Dew point temperature conversion chart

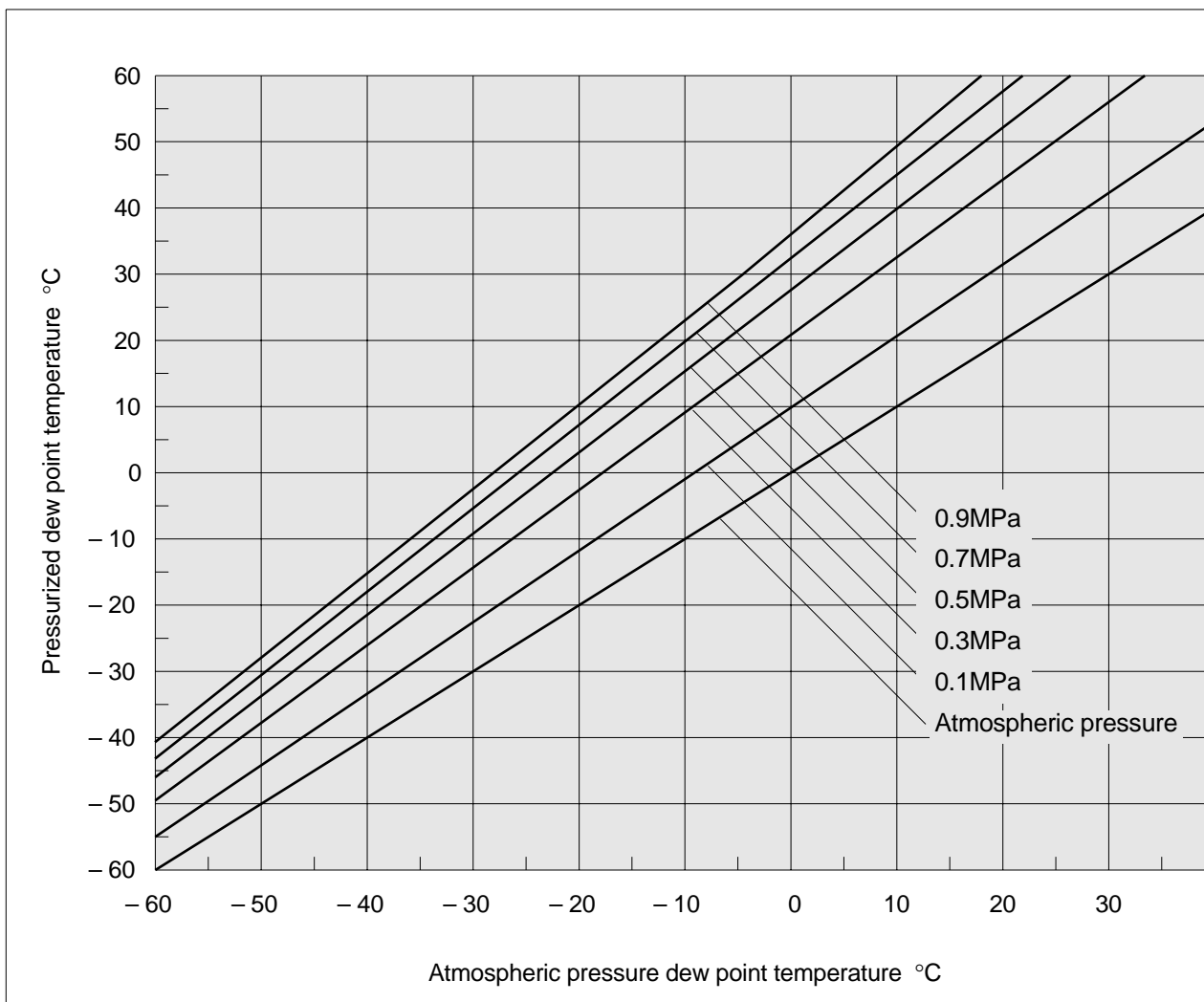

Step 2 Tentative determination of membrane air dryer model

Tentative determination of model from performance charts (Refer to pages 3, 5 and 7.)

Note: When the inlet air temperature is not 25°C, make a tentative model determination from the performance charts referring to the information below. For each increase of 1°C in the inlet air temperature, the outlet air atmospheric pressure dew point increases by approximately 0.8°C.

(Inlet air pressure: 0.7MPa
Outlet air flow rate: At rated flow rate)

Step 3 Confirmation of purge air flow rate

Read from purge air flow rate charts (Refer to page 31.)

Conditions: Membrane air dryer model
Inlet air pressure [MPa]

Step 4 Confirmation of calculation for inlet air flow rate Q1, and compressed air supply capacity

Inlet air flow rate Q_1 [/min (ANR)] =
Outlet air flow rate [/min (ANR)] + Purge air flow rate [/min (ANR)]

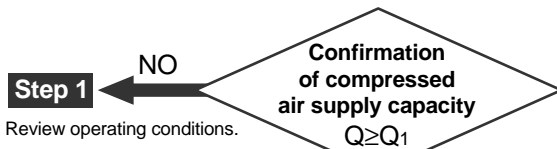

Step 1 Review operating conditions.

YES

Step 5

Step 5 Confirmation of pressure drop ΔP_1 [MPa]

Single style (Refer to pages 30 and 31.)
Unit (Refer to pages 16 and 17.)

Conditions: Membrane air dryer model
Inlet air flow rate Q_1 [/min (ANR)]
Inlet air pressure [MPa]

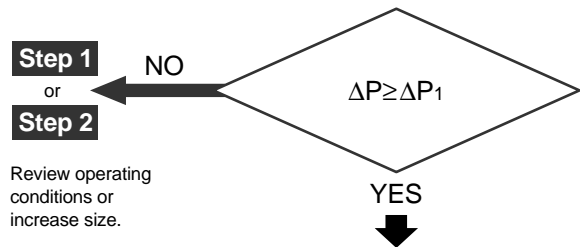

Step 1
or
Step 2

Review operating conditions or increase size.

Step 6 Examine drain discharge method (for units), accessories and optional specifications.

Single style (Refer to pages 1, 4 and 6.)
Unit (Refer to page 12.)

Model Determination

Flow Rate Characteristics

IDG1

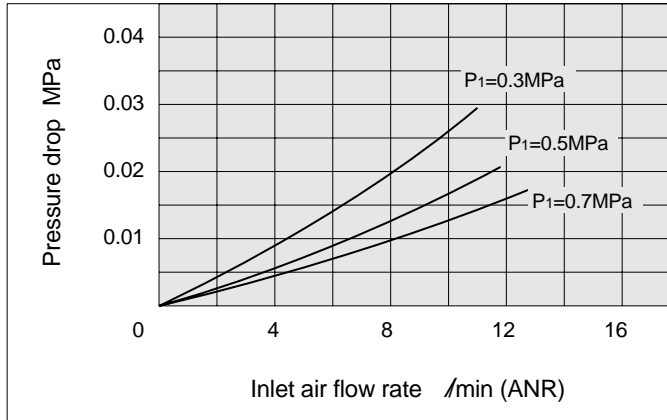

IDG5, IDG5H

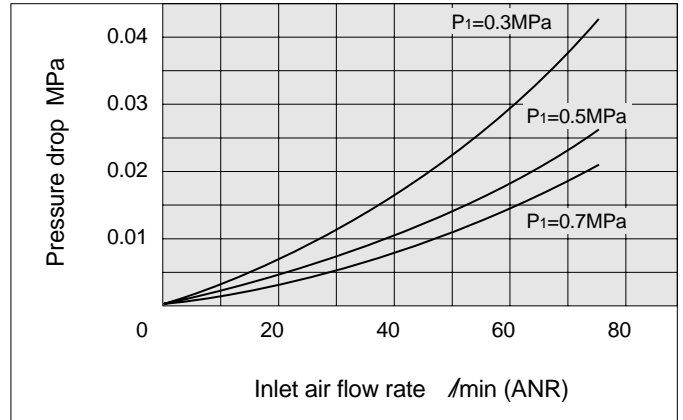

IDG10, IDG10H

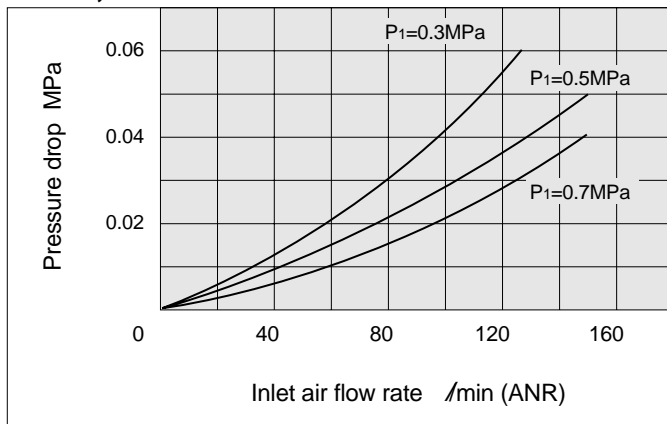

IDG20, IDG20H

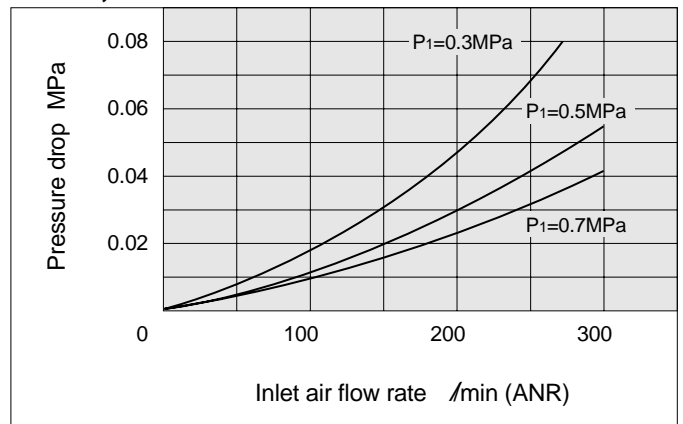

IDG30, IDG30H, IDG30L

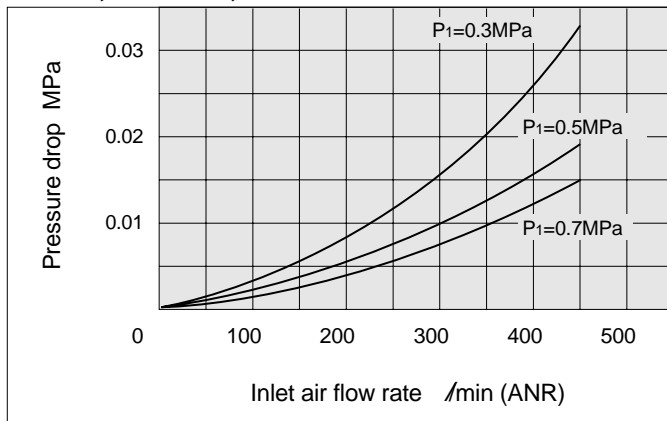

IDG50, IDG50H, IDG50L

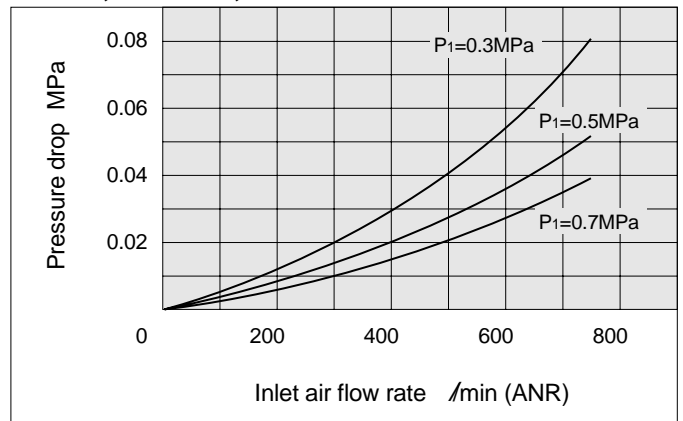

IDG60, IDG60H

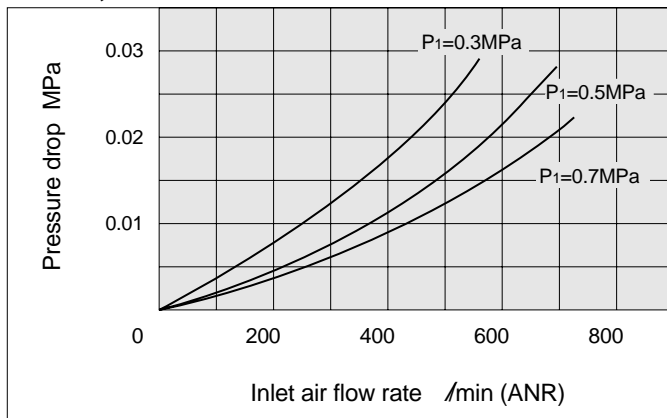

IDG60L

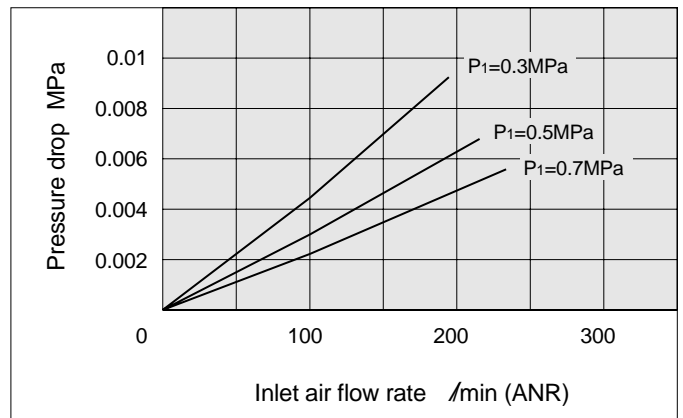

Conditions: Inlet air temperature 25°C, P₁: Inlet air pressure

IDG75, IDG75H

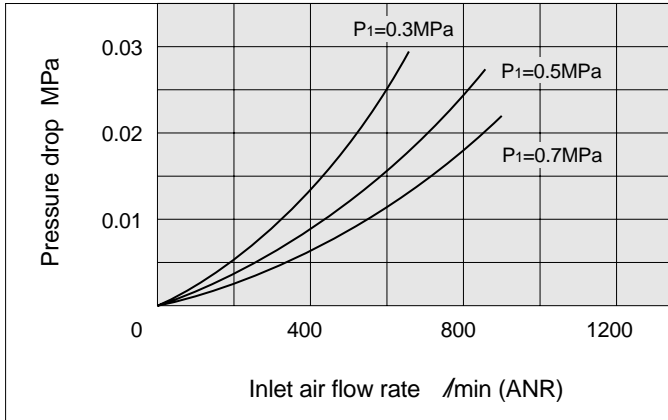

IDG75L

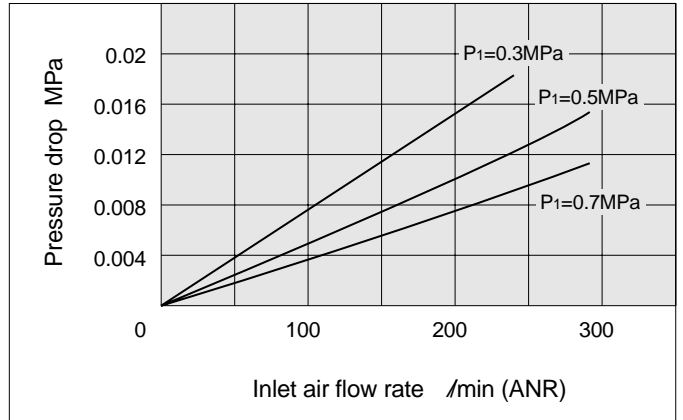

IDG100, IDG100H

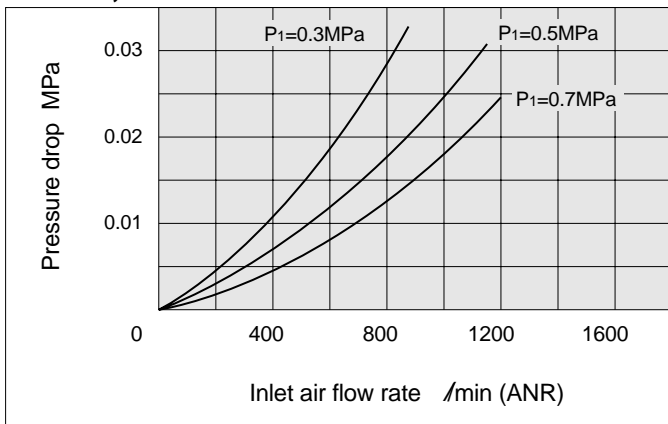

IDG100L

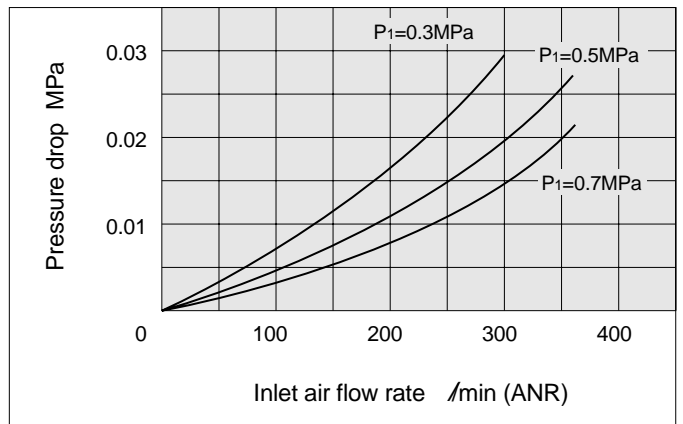

Series IDG

Purge Air Flow Rate Charts

Conditions: Inlet air temperature 25°C

IDG1

**IDG5
IDG5H**

**IDG10
IDG10H**

**IDG20
IDG20H**

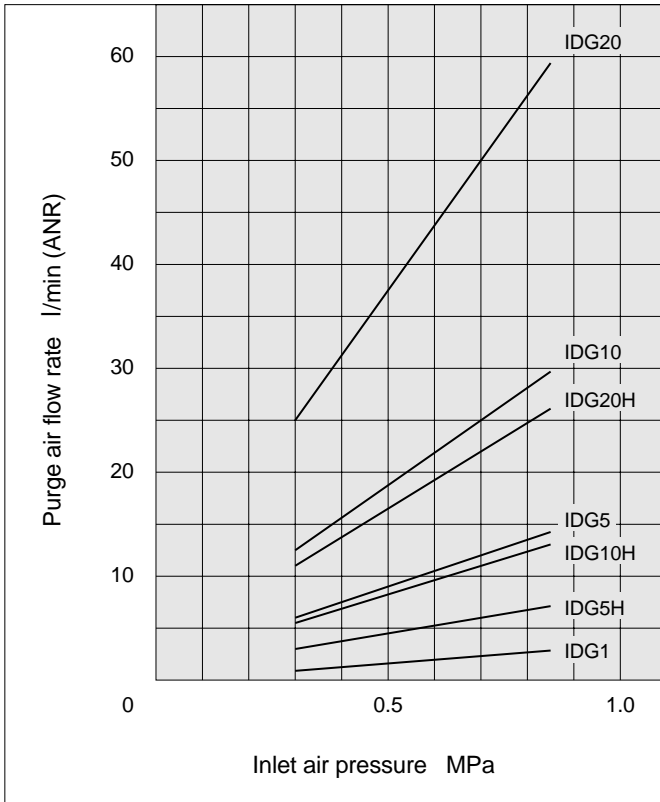

**IDG30
IDG30H**

**IDG30L
IDG50**

**IDG50H
IDG50L**

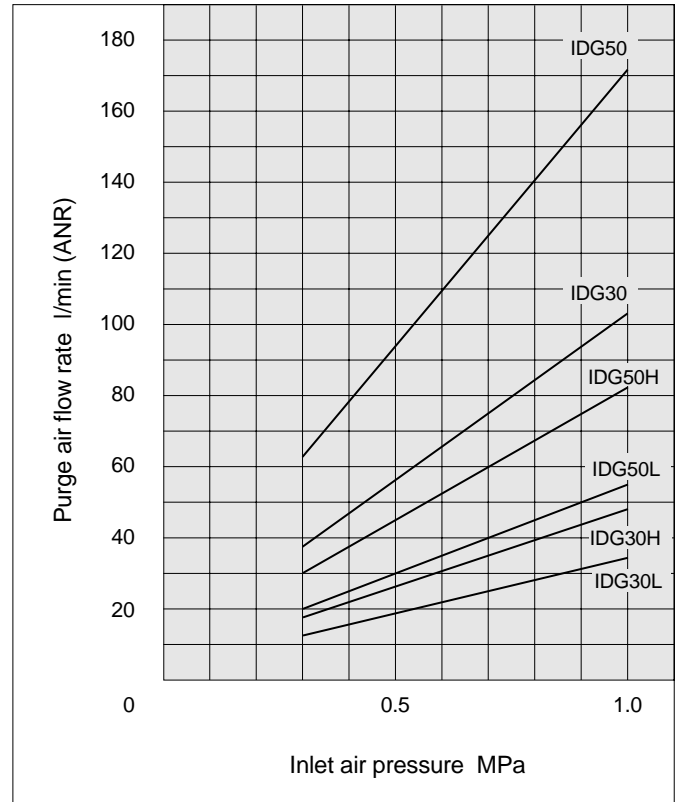

**IDG60
IDG60H**

**IDG75
IDG75H**

**IDG100
IDG100H**

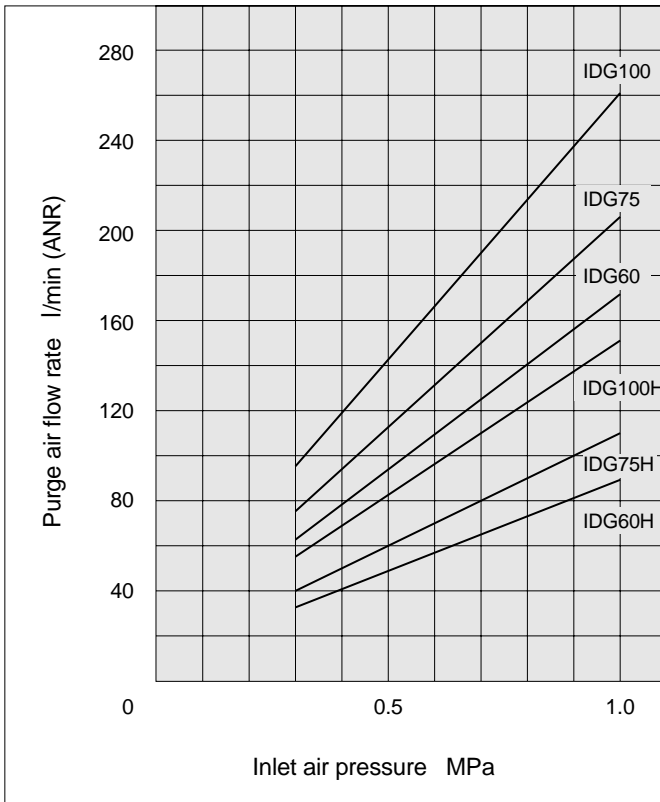

IDG60L

IDG75L

IDG100L

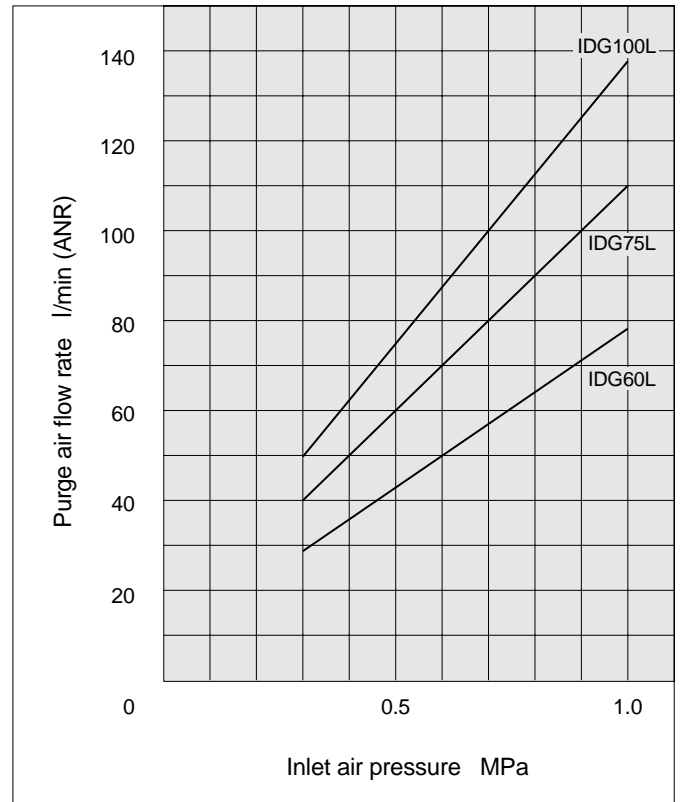





Series IDG Safety Instructions

These safety instructions are intended to prevent a hazardous situation and/or equipment damage. These instructions indicate the level of potential hazard by a label of "**Caution**", "**Warning**" or "**Danger**". To ensure safety, be sure to observe ISO 4414 Note 1), JIS B 8370 Note 2) and other safety practices.

 **Caution** : Operator error could result in injury or equipment damage.

 **Warning** : Operator error could result in serious injury or loss of life.

 **Danger** : In extreme conditions, there is a possible result of serious injury or loss of life.

Note 1) ISO 4414: Pneumatic fluid power – Recommendations for the application of equipment to transmission and control systems

Note 2) JIS B 8370: General Rules for Pneumatic Equipment

Warning

1. The compatibility of pneumatic equipment is the responsibility of the person who designs the pneumatic system or decides its specifications.

Since the products specified here are used in various operating conditions, their compatibility for the specific pneumatic system must be based on specifications or after analysis and/or tests to meet your specific requirements.

2. Only trained personnel should operate pneumatically operated machinery and equipment.

Compressed air can be dangerous if an operator is unfamiliar with it. Assembly, handling or repair of pneumatic systems should be performed by trained and experienced operators.

3. Do not service machinery/equipment or attempt to remove components until safety is confirmed.

1. Inspection and maintenance of machinery/equipment should only be performed after confirmation of safe locked-out control positions.

2. When equipment is to be removed, confirm the safety process as mentioned above. Cut the supply pressure for this equipment and exhaust all residual compressed air in the system.

3. Before machinery/equipment is restarted, take measures to prevent shooting-out of cylinder piston rod, etc. (Bleed air into the system gradually to create back pressure.)

4. Contact SMC if the product is to be used in any of the following conditions:

1. Conditions and environments beyond the given specifications, or if product is used outdoors.

2. Installation on equipment in conjunction with atomic energy, railway, air navigation, vehicles, medical equipment, food and beverages, recreation equipment, emergency stop circuits, press applications, or safety equipment.

3. An application which has the possibility of having negative effects on people, property, or animals, requiring special safety analysis.



Series IDG

Air Cleaning Equipment Precautions 1

Be sure to read before handling.

Precautions on Design

Employ a safe design so that the following type of unexpected conditions will not occur.

⚠ Warning

1. Design so that high temperature compressed air does not flow downstream.

In case of cooling equipment failure (stoppage of cooling water in water cooled type after cooler, stoppage of fan motor in air cooled type after cooler, etc.) on the air supply side, high temperature compressed air can flow downstream and cause damage or malfunction of downstream equipment (separators, air dryers, etc.).

2. Use a design that allows for stoppage of the compressed air supply.

Compressed air flow may be stopped by clogging of separators, etc.

⚠ Caution

1. Use a design that prevents reverse pressure and back flow.

Reverse pressure and back flow can cause equipment damage or malfunction, etc.

Give attention to safety measures, including handling procedures.

Selection

⚠ Warning

1. When selecting equipment, first adequately confirm the purpose for which it will be used, the required specifications and the operating conditions (pressure, flow rate, temperature, environment), etc. Then select equipment from the latest catalogs without exceeding the specification ranges. Contact SMC in advance regarding any questions.

2. Do not use for caisson shields, breathing, medical treatment or for blowing of medicine or food products which will enter the human body.

This cleaning equipment is exclusively for use with industrial compressed air, and should not be used for other applications. If other application is unavoidable, give attention to safety measures and contact SMC in advance.

3. This product cannot be used on board vehicles or vessels.

This product cannot be used on board vehicles, vessels or other transportation devices, because vibration will cause damage. If this type of use is unavoidable, contact SMC in advance.

Selection

⚠ Caution

1. Do not allow flow greater than the rated flow rate.

If the flow exceeds the rated flow rate even momentarily, this can cause drainage and oil to be sprayed into the downstream side or cause damage.

2. The product cannot be used with low pressure air (blowers).

Cleaning equipment is exclusively for use with compressed air at a minimum operating pressure determined according to the equipment. Using below the minimum operating pressure can cause reduced performance and malfunction. If this type of use is unavoidable, contact SMC in advance.

Mounting

⚠ Caution

1. Confirm the mounting position.

Since the mounting position is different for each piece of equipment, this should be confirmed either in this catalog or in the instruction manual. Mounting in a tilted position can cause faulty drainage discharge, auto drain malfunction and damage in some types of equipment.

2. Ensure sufficient maintenance space.

When installing and mounting, be sure to allow the space required for maintenance and inspections. Confirm the necessary maintenance space in the instruction manual for each piece of equipment.

Piping

⚠ Caution

1. Preparation before piping

Before piping is connected, it should be thoroughly blown out with air (flushing) or washed to remove chips, cutting oil and other debris from inside the pipe.

2. Wrapping of pipe tape

When screwing together pipes and fittings, etc., be certain that chips from the pipe threads and sealing material do not get inside the piping.

Further, when pipe tape is used, leave 1.5 to 2 thread ridges exposed at the end of the threads.

3. Implement measures to prevent drainage from collecting inside piping.

Drains should be installed in the lower sections of piping that rises, or piping should be designed with a slight taper provided along the direction of flow so that drainage will not accumulate.

4. Confirm IN and Out ports.

When piping is being installed, take care to prevent incorrect connection of the water and air sides, or the IN and OUT ports.



Series IDG

Air Cleaning Equipment Precautions 2

Be sure to read before handling.

Air Supply

Warning

1. Do not use with fluids other than compressed air.

Cleaning equipment is designed exclusively for use with compressed air. Contact SMC in advance if a fluid other than compressed air is to be used.

2. Do not use compressed air which contains chemicals, organic solvents or corrosive gases.

Do not use compressed air containing chemicals, organic solvents, salt or corrosive gases, as this can cause damage and/or malfunction, etc.

3. Use within the operating pressure range.

The operating pressure range is determined by the equipment being used. Operation beyond this range can cause damage, failure or malfunction.

Operating Environment

Warning

1. Do not use in the following environments, as this can cause failure.

1. Locations with an atmosphere of corrosive gases, organic solvents or chemical solutions, or where there may be contact with these.
2. Locations where there is contact with sea spray, water or steam.
3. Locations which receive direct sunlight. (Sunlight should be blocked to prevent deterioration of resin from ultra violet rays, and over heating, etc.)
4. Locations near heat sources with poor ventilation. (Heat sources should be blocked off, because radiated heat may cause damage due to softening of materials.)
5. Locations with impacts or vibration. (Check the specifications for each series.)
6. Locations with high moisture and dust. (Contact SMC in advance.)

2. Adhere to the fluid and ambient temperature ranges.

The fluid and ambient temperatures are determined by the equipment being used. Operation beyond this range can cause damage, failure or malfunction, etc.

Maintenance

Warning

1. If an abnormality occurs, stop the compressed air.

If abnormalities such as smoke, unusual odor or unusual noise occur, stop the inflow of compressed air, as this may indicate a fire.

2. When performing inspections, set the compressed air pressure at zero.

When the compressed air side is to be disassembled for auto drain inspection, separator element replacement or film module replacement, etc., confirm that the pressure is at zero before proceeding.

Caution

1. Do not place heavy objects on the unit or use it as a step.

The equipment may be deformed or damaged, and if balance is lost, falling may cause injury.

2. Discharge drainage regularly.

Accumulation of drainage in equipment, piping or other areas can cause malfunction of the equipment or unexpected trouble due to splash over into the downstream side, etc. Therefore, the amount of drainage and the operation of auto drains should be checked every day.



Series IDG

Specific Product Precautions 1

Be sure to read before handling.

Refer to pages 34 through 36 for safety instructions and air cleaning equipment precautions.

Precautions on Design

⚠ Caution

1. Devise a layout which considers the position of purge air discharge ports.

Purge air is humid air. Devise a layout in which purge air will not cause trouble such as corrosion or malfunction of peripheral equipment.

2. When very clean air is required

(supply to air bearings, blowing of semiconductor parts, etc.)

Install a micro mist separator or super mist separator on the downstream side (end terminal) of the membrane air dryer (unit).

Furthermore, grease is used in the regulator that is used in units (V type). When very clean air is required, install a separator as mentioned above on the downstream side, or instead of a regulator, use a type (special order) that is fitted with a micro mist separator regulator (AWD series).

3. Time to reach the rated dew point

A certain amount of time is required to reach the rated dew point after beginning the flow of air into the membrane air dryer. Using the times below as a guide, begin operating downstream equipment after reaching the rated dew point.

Standard dew point – 20°C, – 15°C: Approx. 10min.

Standard dew point – 40°C: Approx. 30 min.*

*This time can be shortened as described below.

- 1) Provide a valve on the downstream side of the membrane air dryer.
- 2) Supply air with the valve closed. Only purge air flows into the membrane air dryer.
- 3) After 15 minutes or more, open the valve and let air flow to the downstream equipment.

4. Dehumidification performance when inlet air temperature changes

The performance charts indicate an inlet air temperature of 25°C. See below for other temperatures.

For each increase of 1°C in the inlet air temperature, the outlet air atmospheric pressure dew point increases by approximately 0.8°C.

(Inlet air pressure: 0.7MPa, Outlet air flow rate: At rated flow rate)

Selection

⚠ Caution

1. Consider the purge air flow rate.

Read the purge air flow rate from the charts and calculate the "required outlet air flow rate + purge air flow rate".

The air supply capacity must be at least equal to the calculated flow or the required outlet air flow rate cannot be obtained.

2. Selection on a line in which a mist separator or micro mist separator is already installed

Confirm the operating air flow rate and pressure, and select a membrane air dryer in accordance with the model selection method (page 28). If a membrane air dryer is selected based on the port sizes of previously installed equipment, a model may be selected which is too small and the dehumidification capacity may be insufficient.

3. With fittings for purge air discharge (Option: P)

As the length of the tubing for purge air discharge increases, dehumidification performance decreases. Use the specified tubing size and keep the length within 5 meters or less. Refer to "Outlet air atmospheric pressure dew point by purge air discharge tube length" on page 3 for information on this subject.

Mounting

⚠ Caution

1. Do not obstruct the purge air discharge ports.

If purge air back pressure becomes too high or purge air stops flowing, dehumidification performance will decrease or become impossible.

2. Be sure to install a mist separator and micro mist separator or a micro mist separator with pre-filter on the upstream side of the membrane air dryer.

If the inlet air contains oil or water drops, etc., performance will be reduced. (A mist separator and micro mist separator or a micro mist separator with pre-filter are already installed on the unit types.)

3. Install a regulator on the downstream side of the membrane air dryer.

If it is installed on the upstream side, dehumidification performance will be reduced.

4. Use adequate care in handling.

There is a danger of damage if dropped.



Series IDG

Specific Product Precautions 2

Be sure to read before handling.

Refer to pages 34 through 36 for safety instructions and air cleaning equipment precautions.

Piping

⚠ Warning

1. Confirm locking of case and body.

When using in a unit, be sure the air pressure is zero before using a mist separator or micro mist separator with modular connections. Also, confirm that the body and case are locked together with a click before starting the flow of compressed air.

2. Confirm tightening of the holder.

(for IDG30 to IDG100, IDG30H to IDG100H, IDG30L to IDG100L)

Before starting the flow of compressed air, turn the membrane air dryer's holder in its tightening direction, confirming that it is completely tightened and that the case will not come off.

3. Confirm tightening of insert fittings.

(for IDG1)

Before starting the flow of compressed air, turn the union nut in its tightening direction, confirming that it is completely tightened and that the membrane module will not come off.

4. Minimum bending radius

(for IDG1)

When installing piping for the membrane air dryer, maintain a minimum bending radius of 35mm or more. Furthermore, do not bend the sections that are within 50mm from the end of the membrane modules.

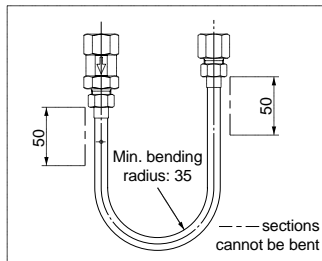

5. With fittings for purge air discharge

(Option: P)

The piping of purge air for dehumidification and for the dew point checker can be combined, but do not merge these with compressed air lines or drain piping, etc., as this can cause damage.

Piping

⚠ Caution

1. Use of tools

Hold the upper portion of the body (die-cast aluminum section) with a spanner or adjustable angle wrench. Do not turn it while holding the case section.

2. Drain piping for separators

When installing drain piping for mist separators or micro mist separators, use the prescribed tubing size and keep the length within 5 meters or less.

Also, be sure that the tubing does not stand up or become folded over.

3. Piping materials for low dew point air

When air with a low dew point (-40°C or less) is required, do not use nylon tubing for the membrane air dryer's downstream piping. A characteristic of nylon tubing is that it is affected by the ambient air, and it may not be possible to obtain the specified low dew point at the end of the tube. For low dew point air, use stainless steel or Teflon® piping.

4. With fittings for purge air discharge (Option: P)

(for IDG60 to IDG100, IDG60H to IDG100H, IDG60L to IDG100L)

To install piping for dehumidification purge air discharge, attach tubing of the prescribed size to the hose nipple section and then secure it with tubing bands.

Air Supply

⚠ Caution

1. Compressed air supply capacity

An air supply is necessary which has a supply capacity at least equal to the "required outlet air flow rate (dry air flow rate) + purge air flow rate". Confirm the purge air flow rate with the purge air flow rate charts (pages 32).

Operating Environment

⚠ Caution

1. Do not use at temperatures (fluid or ambient temperatures) higher than the prescribed operating conditions.

Resin is used in the membrane module, and it can be damaged by operation at high temperatures. Especially when installed immediately after a reciprocating type air compressor, confirm that the fluid temperature does not exceed the range of operating conditions during use.

2. Keep the inlet air temperature lower than the ambient temperature.

If the membrane air dryer's body is cooled by the surrounding air, water drops may accumulate inside and reduce its dehumidification capacity.

Teflon® is a registered trademark of DuPont.



Series IDG

Specific Product Precautions 3

Be sure to read before handling.

Refer to pages 34 through 36 for safety instructions and air cleaning equipment precautions.

Maintenance

Warning

1. Do not remove the orifice (plug) when in a pressurized state.

Never remove the orifice (plug) while under pressure, as it can fly out causing a hazard.

Caution

1. Confirming dehumidification function with the dew point indicator

Observe the color of the dew point indicator to confirm whether the membrane air dryer is functioning normally.

[When dew point indicator color is blue: Functioning normally]

[When dew point indicator color is pink: Dew point temperature is high (outlet air is moist) Note: Atmospheric pressure dew point Approx. -10°C or more]

It takes about 1 hour from the start of air flow for the dew point indicator color to change.

2. Confirmation of oil contamination with dew point indicator

When the dew point indicator color turns brown, a large amount of oil has contaminated the membrane air dryer. In this case, replace the dew point indicator and membrane module.

3. Element replacement period

The element of the mist separator and micro mist separator or micro mist separator with pre-filter, which are installed on the inlet side of the membrane air dryer, should be replaced after about two years of use.

Even within this period, replace the element if the drop in the unit's pressure reaches 0.2MPa.

4. Membrane module replacement period

Replace the membrane module if the dew point indicator's color turns white, pink or brown.

When periodic replacement is to be performed, the schedule will depend on the operating conditions, but as a general rule replacement should be performed after four years of use. Even within this period, replace the module if the dew point indicator's color changes to any of the colors mentioned above.

5. Tightening torque for mounting of membrane module and case

(for IDG5, 10, 20, 5H, 10H, 20H)

Tighten within the prescribed tightening torque range.

Tightening outside of this range can cause damage to the membrane module, case and mounting screws, or cause poor sealing, etc.

(Confirm the tightening torque range in the instruction manual.)

6. Pressure gauge installation

A pressure gauge should be installed at the entry side of the membrane air dryer (unit) for maintenance and inspection purposes.

**Austria**

SMC Pneumatik GmbH (Austria).
Grakstrasse 8, A-2100 Körneuburg
Phone: 02262-62280, Fax: 02262-62285

**Germany**

SMC Pneumatik GmbH
Boschring 13-15, D-63329 Egelsbach
Phone: 06103-4020, Fax: 06103-402139

**Netherlands**

SMC Pneumatics BV
Postbus 308, 1000 AH Amsterdam
Phone: 020-5318888, Fax: 020-5318880

**Slovenia**

SMC Slovenia d.o.o.
Grajski trg 15, 8360 Zuzemberk
Phone: 068-88 044 Fax: 068-88 041

**Belgium**

SMC Pneumatics N.V./S.A.
Nijverheidsstraat 20, B-2160 Wommelgem
Phone: 03-355-1464, Fax: 03-355-1466

**Greece**

S. Parianopoulos S.A.
9, Konstantinoupolios Street,
GR-11855 Athens
Phone: 01-3426076, Fax: 01-3455578

**Norway**

SMC Pneumatics (Norway) A/S
Wollsveien 13 C, granfoss Noeringspark
N-134 Lysaker, Norway
Phone: 22 99 6036, Fax: 22 99 6103

**Spain**

SMC España, S.A.
Zuazobidea 14, Pol. Ind. Jundiz,
E-01015 Vitoria
Phone: 945-184 100, Fax: 945-184 124

**Czech**

SMC Czech.s.r.o.
Kodanska 46, CZ-100 10 Prague 10
Phone: 02-67154 790, Fax: 02-67154 793

**Hungary**

SMC Hungary Kft.
Budafoki ut 107-113, 1117 Budapest
Phone: 01-204 4366, Fax: 01-204 4371

**Poland**

Semac Co., Ltd.
PL-05-075 Wesola k/Warszaway, ul. Wspolna 1A
Phone: 022-6131847, Fax: 022-613-3028

**Sweden**

SMC Pneumatics Sweden A.B.
Ekhagsvägen 29-31, S-14105 Huddinge
Phone: 08-603 07 00, Fax: 08-603 07 10

**Denmark**

SMC Pneumatik A/S
Jens Juuls vej 32, DK-8260 Viby J
Phone: 45-70252900, Fax: 45-70252901

**Ireland**

SMC Pneumatics (Ireland) Ltd.
2002 Citywest Business Campus,
Naas Road, Saggart, Co. Dublin
Phone: 01-403 9000, Fax: 01-464 0500

**Portugal**

SMC España (Sucursal Portugal), S.A.
Rua de Engº Ferreira Dias 452, 4100 Porto
Phone: 02-610-89-22, Fax: 02-610-89-36

**Switzerland**

SMC Pneumatik AG
Dorfstrasse 7, CH-8484 Weisslingen
Phone: 052-396-3131, Fax: 052-396-3191

**Estonia**

Teknoma Eesti AS
Mustamäe tee 5, EE-0006 Tallinn, Estonia
Phone: 259530, Fax: 259531

**Italy**

SMC Italia S.p.A
Via Garibaldi 62, I-20061 Carugate, (Milano)
Phone: 02-92711, Fax: 02-92150394

**Romania**

SMC Romania srl
Vasile Stroescu 19, Sector 2, Bucharest
Phone: 01-210-1354, Fax: 01-210-1680

**Turkey**

Entek Pnömatik San. ve Tic Ltd. Sti.
Perpa Tic. Merkezi Kat: 11 No: 1625,
TR-80270 Okmeydanı Istanbul
Phone: 0212-221-1512, Fax: 0212-220-2381

**Finland**

SMC Pneumatikka OY
Veneentekijantie 7, SF-00210 Helsinki
Phone: 09-681021, Fax: 09-6810233

**Latvia**

Ottensten Latvia SIA
Ciekurkalna Prima Gara Linija 11,
LV-1026 Riga, Latvia
Phone: 371-23-68625, Fax: 371-75-56748

**Russia**

SMC Pneumatik LLC
Centrako Business Centre 103,
Bolshoy Prospect V.O., 199106 St. Petersburg
Phone: 812-1195131, Fax: 812-1195129

**UK**

SMC Pneumatics (UK) Ltd
Vincent Avenue, Crownhill,
Milton Keynes, MK8 0AN
Phone: 01908-563888 Fax: 01908-561185

**France**

SMC Pneumatique, S.A.
1, Boulevard de Strasbourg, Parc Gustave Eiffel
Bussy Saint Georges
F-77607 Marne La Vallée Cedex 3
Phone: 01-6476 1000, Fax: 01-6476 1010

**Lithuania**

UAB Ottensten Lietuva
Savanoriu pr.180, LT-2600 Vilnius, Lithuania
Phone/Fax: 370-2651602

**Slovakia**

SMC Slovakia s.r.o.
Pribinova ul. C. 25, 819 02 Bratislava
Phone: 0-563 3548, Fax: 07-563 3551

OTHER SUBSIDIARIES WORLDWIDE:

ARGENTINA, AUSTRALIA, BOLIVIA, BRASIL, CANADA, CHILE, CHINA, HONG KONG, INDIA, MALAYSIA, MEXICO, NEW ZEALAND, PHILIPPINES, SINGAPORE, SOUTH KOREA, TAIWAN, THAILANDIA, USA, VENEZUELA

For more information, please contact your local SMC Regional Centre

SMC UK Regional Centres**BELFAST**

Tel:02890 778414 Fax:02890 778422
SMC Pneumatics (UK) Ltd
Northern Ireland Regional Centre
Suite 3, Shaftesbury House, Edgewater Road
Belfast
BT3 9JQ

CRAWLEY

Tel:01293 614094 Fax:01293 614135
SMC Pneumatics (UK) Ltd
Crawley Regional Centre
9 Pelham Court, Pelham Place, Broadfield
Crawley
RH11 9AZ

IPSWICH

Tel:01473 240040 Fax:01473 747707
SMC Pneumatics (UK) Ltd
Ipswich Regional Centre
Unit 6 & 7, Alpha Business Park
16-18 Whitehouse Road, Ipswich, Suffolk
IP1 5LT

NEWCASTLE

Tel:0191 487 2040 Fax:0191 487 2041
SMC Pneumatics (UK) Ltd
Newcastle Regional Centre
Unit B6, Marquis Court, Marquis Way
Team Valley Trading Estate, Gateshead
Tyne & Wear
NE11 0RU

BIRMINGHAM

Tel:01675 467177 Fax:01675 465073
SMC Pneumatics (UK) Ltd
Birmingham Regional Centre
24 The Courtyard, Gorseley Lane, Coleshill
Warwickshire
B46 1JA

CUMBERNAULD

Tel:01236 781133 Fax:01236 780611
SMC Pneumatics (UK) Ltd
Scottish Regional Centre
1 Carradale Crescent,
Broadwood Business Park, Cumbernauld
Glasgow
G68 9LE

MANCHESTER

Tel:0161 876 7371 Fax:0161 876 7372
SMC Pneumatics (UK) Ltd
Manchester Regional Centre
3 Modwen Road, Waters Edge Business Park
Ordsall Lane, Salford, Manchester
M5 3EZ

POOLE

Tel:01202 732233 Fax:01202 737743
SMC Pneumatics (UK) Ltd
Poole Regional Centre
Unit 4, Acorn Business Centre, Ling Road
Poole, Dorset
BH12 4NZ

BRISTOL

Tel:01179 522155 Fax:01179 522186
SMC Pneumatics (UK) Ltd
Bristol Regional Centre
5 East Gate Office Centre
East Gate Road, Eastville, Bristol
BS5 6XX

DROITWICH

Tel: 01905 774544 Fax: 01905 797343
SMC Pneumatics (UK) Ltd
Droitwich Regional Centre
Hampton Park, Hampton Lovett
Droitwich, Worcestershire
WR9 0NX

MILTON KEYNES

Tel: 01908 265247 Fax: 01908 262705
SMC Pneumatics (UK) Ltd
Vincent Avenue, Crownhill, Milton Keynes
MK8 0AN

SHEFFIELD

Tel: 01909 565504 Fax: 01909 569717
SMC Pneumatics (UK) Ltd
Sheffield Regional Centre
Unit 4, North Anston Business Park
Houghton Road, North Anston, Sheffield
S25 4JJ

SMC UK Distributors**Birmingham**

JAMES LISTER
Tel: 0121 5803800
Fax: 0121 5535951

Bristol

APPLIED AUTOMATION
Tel: 0117 9827769
Fax: 0117 9235522

Cardiff

WALES FLUID POWER
Tel: 02920 494551
Fax: 02920 481955

Blackburn

BLACKBURN PNEUMATIC SYSTEMS LTD
Tel: 01254 682232
Fax: 01254 682224

Bury St Edmunds

PNEUMATIC LINES
Tel: 01284 706239
Fax: 01284 761218

Plymouth

APPLIED AUTOMATION
Tel: 01752 343300
Fax: 01752 341161