

## Zubehör

### Zwischenstück

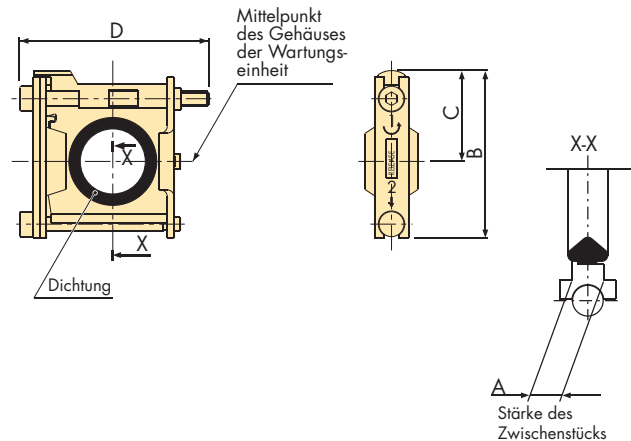

Bestell- Nr.	A	B	C	D	Verwendbares Modell
<b>Y100</b>	6	27	15	33	AC 10
<b>Y200</b>	3	35.5	18.5	48	AC 20
<b>Y300</b>	4	47	26	59	AC 30
<b>Y400</b>	5	57	31	65	AC 40
<b>Y500</b>	5	61	33	70	AC 40-06
<b>Y600</b>	6	75.5	41	86	AC50, AC60

### Ersatzteile

Beschreibung	Material	Bestell-Nr.				
		Y100	Y200	Y300	Y400	Y500
Dichtung	HNBR	<b>Y100P-060AS</b> <small>Anm. 1)</small>	<b>Y200P-060S</b>	<b>Y300P-060S</b>	<b>Y400P-060S</b>	<b>Y500P-060S</b>

Anm. 1) Y-100 wird mit 2 O-Ringen aus NBR geliefert.

### Zwischenstück mit Befestigungselement

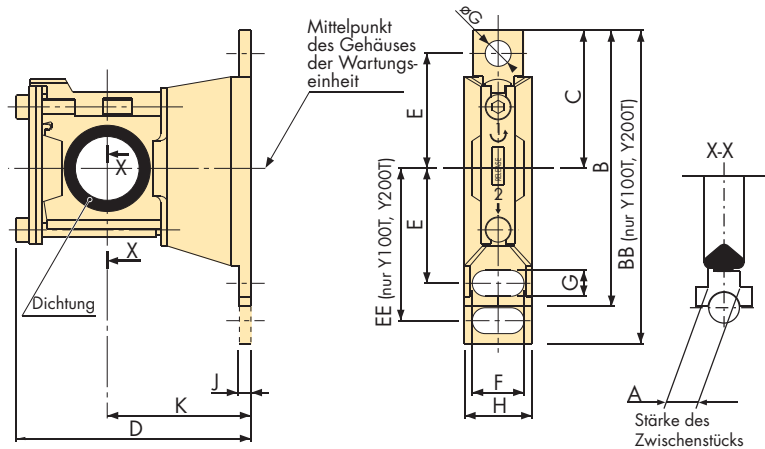
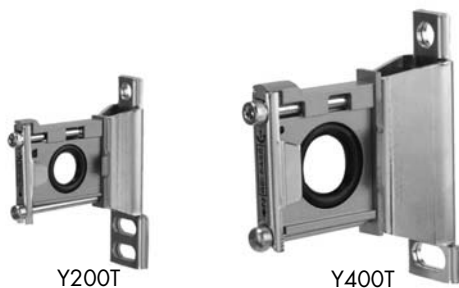

Bestell-Nr.	A	B	BB	C	D	E	EE	F	G	øG	H	J	K	Verwendbares Modell
<b>Y100T</b>	6	—	56	24.5	40.5	20	27	6.8	4.5	4.5	14	2.8	25	AC10
<b>Y200T</b>	3	—	67	29	53	24	33	12	5.5	5.5	19	3.2	30	AC20
<b>Y300T</b>	4	82	—	41	68	35	—	14	7	7	21	4	41	AC30
<b>Y400T</b>	5	96	—	48	81.5	40	—	18	9	9	26	4	50	AC40
<b>Y500T</b>	5	96	—	48	86	40	—	18	9	9	27	4.6	50	AC40-06
<b>Y600T</b>	6	120	—	60	112	50	—	20	11	11	31	6.4	70	AC50, AC55, AC60, AC50B, AC55B, AC60B

### Ersatzteile

Beschreibung	Material	Bestell-Nr.				
		Y100T	Y200T	Y300T	Y400T	Y500T
Dichtung	HNBR	<b>Y100P-060AS</b> <small>Anm. 1)</small>	<b>Y200P-060S</b>	<b>Y300P-060S</b>	<b>Y400P-060S</b>	<b>Y500P-060S</b>

Anm. 1) Y-100T wird mit 2 O-Ringen aus NBR geliefert.

