



Installation and Maintenance Manual

EX12*-SMB1 Series (Mitsubishi MELSEC-A Series, MELSECNET/mini-S3 Data Link System)

For future reference, please keep this manual in a safe place

This manual should be read in conjunction with the current product catalogue

Safety Instructions

These safety instructions are intended to prevent a hazardous situation and/or equipment damage. These instructions indicate the level of potential hazard by label of "CAUTION", "WARNING".

To ensure safety, be sure to observe ISO, JIS and other safety practices.

CAUTION : Operator error could result in injury or equipment damage.

WARNING: Operator error could result in serious injury or loss of life.

CAUTION

Thoroughly read this manual and operate the product within the specified range. Follow the instructions.

Do not drop or impart any impact to the product.

Use within specified voltage range. Use outside of specified voltage will cause malfunction, damage to unit, electric shock, and fire. Do not touch the terminals or internal circuit board while they are energized. It may cause malfunction, damage to unit, and electric shock.

Use within operating ambient temperature. Do not use where temperatures can rapidly change even though it is within the specifications. Foreign objects should be prevented from entering the product. Contamination by foreign objects, such as wire chips will cause fire, breakage, and malfunction.

Use within the operating environment of the protection structure. Avoid using IP20 where water or oil, etc. can be splashed. IP65 is achieved by mounting on manifold solenoid valve and process wire entry correctly.

Carry out regular checks to confirm correct operation. Safety may not be maintained by unintentional malfunction or incorrect operation.

WARNING

The product specified here is designed to be used in standard factory automation equipment. Do not use in machinery and/or equipment where operators may be injured, and malfunction or failure may cause loss of life.

Do not disassemble to repair or modify the product.

Specifications

Item	Specifications				
	EX120-SMB1	EX121-SMB1	EX122-SMB1	EX123-SMB1	EX124-SMB1
Output point	16 points				
Output style	Transistor style (NPN open collector style)				
Connecting load	DC24V, Solenoid valve with lamp-surge voltage protection circuit of 2.1W or less				
Residual voltage	0.4V or less				
Occupied station	2 stations				
Power supply voltage	Unit	DC24V±10%, -5%			DC24V±10%
	Solenoid valve	DC24V±10%, -5%			DC24V±10%, -5%
Current consumption	0.1A or less (inside unit)				
Weight (or less)	110g	140g	130g	240g	240g
Operating ambient temperature	0~+55°C (Max. 8 points ON)				
	0~+50°C (All points ON)				
Operating ambient humidity	35~85%RH (No dew allowed)				
Vibration resistance	5G (According to JIS C0912)				
Impact resistance	10G (According to JIS C0911)				
Noise resistance	1000Vp-p pulse width 1μs leading 1ns				
Withstand voltage	AC1000V 50/60Hz for 1 min. between the terminal and the case				
Insulation resistance	More than 2MΩ (DC500V) between the terminal and the case				
Operating atmosphere	No corrosive gas				
Protection class	IP20			IP65	

Outline

This SI unit is able to connect to Mitsubishi Electric Corp. PLC, MELSEC-A series, MELSECNET/mini-S3 Data Link system.

This SI unit has 16 output points (2 stations). Maximum is 512 I/O points (64 stations) per PLC master unit.

Applicable PLC

The following master unit is required to operate MELSECNET/mini-S3 data link system:

AnS type A1S71PT32-S3
A type AJ71PT32-S3

Note: Refer to the Mitsubishi Electric Corporation User Manual for full details.

Applicable solenoid valves

SI unit	Applicable solenoid valve
EX120-SMB1	VQ1000, VQ2000
EX121-SMB1	VQ1000, VQ2000, SX3000, SX5000, SY3000, SY5000
EX122-SMB1	SX3000, SX5000, SY3000, SY5000
EX123-SMB1	VQ2000, VQ4000
EX124-SMB1	VQ2000, VQ4000

Refer to the catalogues for each solenoid valve for details.

CAUTION

If solenoid valves, other than those stated in the chart above, are used, SMC offers no guarantee against malfunction of the SI unit, nor if any load, other than solenoid valves is used.

Terminal block

Terminal name	Connected to
24V	24V supply power cable
0V	0V supply power cable
SDA	RDA of the next station
SDB	RDB of the next station
SG	SG of the previous and next station
RDA	SDA of the previous station
RDB	SDB of the previous station
FG	Grounding conductor and shield
0V (Note 1)	0V supply power cable (for solenoid valve)
24V (Note 1)	24V supply power cable (for solenoid valve)

Note 1: Only EX124-SMB1 corresponds

Wiring (Fig 1)

CAUTION

Power of the product and all other equipment should be turned off while wiring.

Tighten the wiring with terminal screw completely. The terminal screw for connection is M3. Use appropriate crimp-style terminal for the terminal screw. Short circuit, fire, and malfunction will be caused if terminal screw is not tightened enough.

Avoid incorrect wiring. It may damage the product and/or other equipment.

Ensure that the FG terminal is correctly earthed. Power with correct capacity should be prepared by considering the in-rush current when starting.

Influence of noise should be avoided for the wiring. Wiring should be separated from power cables and high voltage cables.

Wiring of the signal cables

Wiring of twisted pair cable should follow the drawing shown in Fig 1. Shielding of shield cable should be one point grounding at receiving side, or sending side. Use cable recommended by Mitsubishi Electric Corporation.

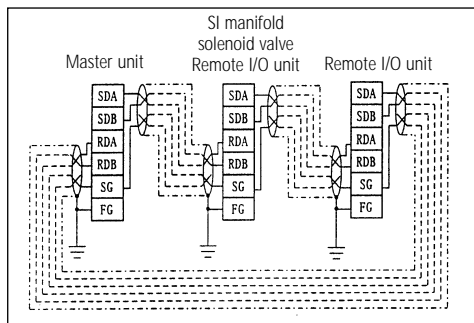

Fig 1

Wiring of power supply

Ensure that the power is within the specified voltage range.

Ensure that the cable is capable of supporting the solenoid and SI unit in terms of rating.

Corresponding SI unit output and solenoid valve

1. Standard wiring

The outputs of the SI unit are assigned from the D side (down) solenoid valve in the order 0, 1, 2, etc.

The SI unit can be mounted from the direction of the D side or the U side (up).

CAUTION

Products exist that can only be mounted from one side of the manifold. Please refer to the current catalogue for each solenoid valve.

When the number of stations on a VQ,SX manifold are 8 or less the internal wiring will default to DOUBLE solenoid wiring.

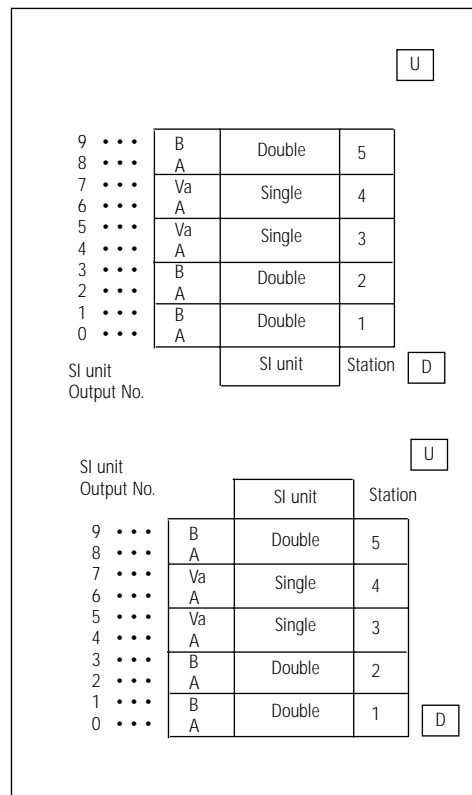

Fig 2

2. Non standard wiring (mixed wiring)

Mixed wiring is available as a non-standard option. If mixed wiring is specified, the positions of the single and double solenoids on the manifold must be indicated when ordering.

LED display

LED name	Content
POWER	Lights in case of the power supply input
RUN	Lights when the data is normally communicating with the master station
SD	Lights when sending of data (high speed flashing)
RD	Lights when receiving of data (high speed flashing)
ERR	Lights when receiving data error and is out in normal communication

Address setting

Power should be turned off to set address. Open the SI unit cover, adjust by turning the address setting switch using a small bladed screwdriver. Setting range is 1~64. As the SI unit has 2 occupied stations, the setting will be 1,3,5...63. The address can be set regardless of the connecting order, however it is not possible to set with vacant positions. It is not possible to set address overlap.

Part identification (Fig 3)

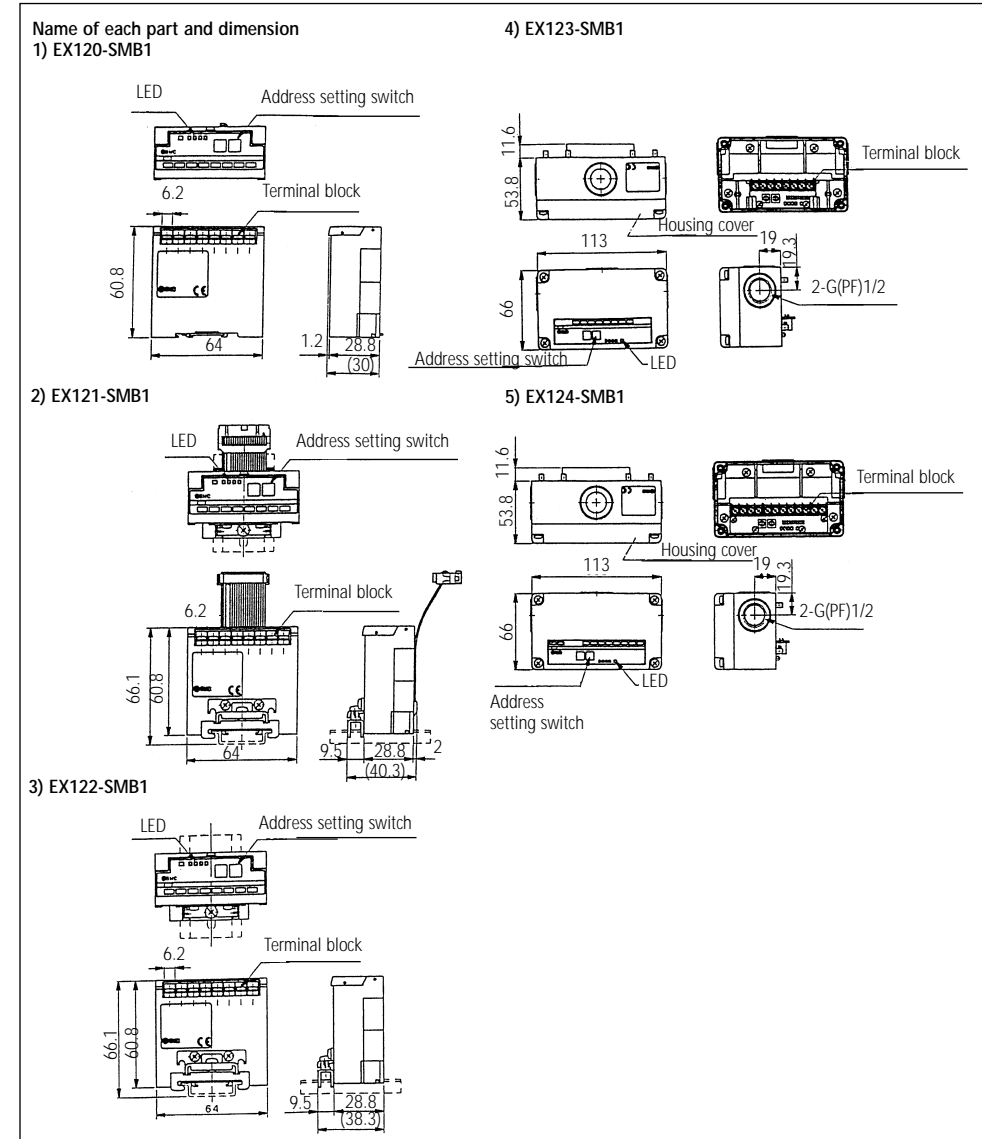

Fig 3

For additional information please contact your local SMC office, see below:

When you enquire about the product, please contact the following

SMC Corporation:

ENGLAND	Phone 01908-563888	TURKEY	Phone 212-2211512
ITALY	Phone 02-927111	GERMANY	Phone 6103-402-0
HOLLAND	Phone 020-5318888	FRANCE	Phone 01-64-76-10-00
SWITZERLAND	Phone 052-396-31-31	SWEDEN	Phone 08-603 07 00
SPAIN	Phone 945-184100	AUSTRIA	Phone 02262-62-280
	Phone 902-255255	IRELAND	Phone 01-4501822
GREECE	Phone 01-3426076	DENMARK	Phone 70 25 29 00
FINLAND	Phone 09-68 10 21	NORWAY	Phone 67-12 90 20
BELGIUM	Phone 03-3551464	POLAND	Phone 48-22-6131847

