

Air Slide Table

Series MXJ

Height: 10 mm/Width: 20 mm/Length: 43 mm (MXJ4)

Traveling parallelism: 0.005 mm

Front mounting accuracy: 0.01 mm

Top mounting accuracy: 0.03 mm

Integrated front mounting part and table result in a highly accurate and rigid top and front mounting surface.



Note 1) Right angle degree of the front mounting surface to the body mounting surface

Note 2) Parallelism of the top mounting surface to the body mounting surface

M3 or M4 screw sizes are used for body mounting.

(Except for MXJ4 top mounting)
Prevents damage to the screws when mounting

Model	MXJ4	MXJ6	MXJ8
Threads for through-hole mounting on the top	M2.5	M3	M3
Threads for tap mounting on the bottom	M3	M4	M4

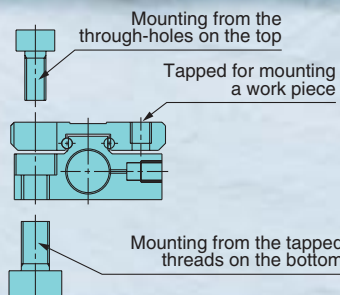

Auto switch mountable in two rows

- Auto switches can be mounted in two rows for all models in the range of MXJ4 to MXJ8.
- Two auto switches can be mounted with a 5 mm or longer stroke.



Actual size

(MXJ6-10)

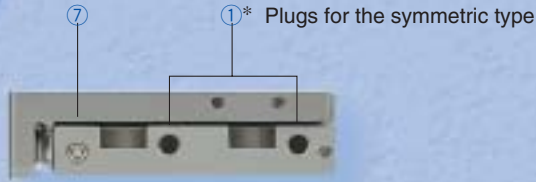

- ① Piping port
- ② Axial piping plate
- ③ Axial piping port
- ④ Retraction end stroke adjuster
- ⑤ Extension end stroke adjuster
- ⑥ Switch rail
- ⑦ Vacuum port (clean specifications)

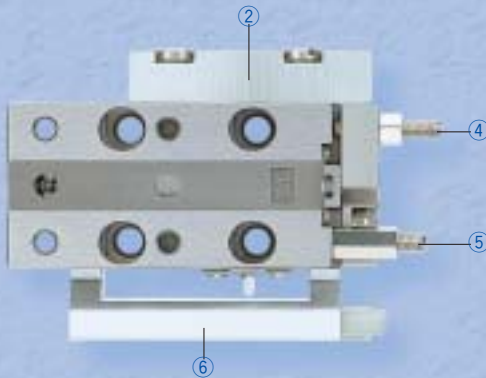
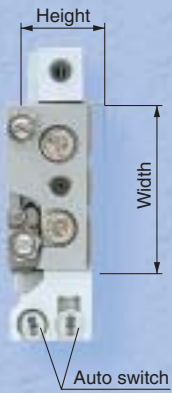

③ Axial Piping

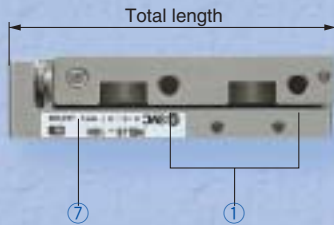

Model	Total length	Width	Height
MXJ4	43	20	10
MXJ6	43	22	11
MXJ8	45	26	13

(mm)

Note) Values of stroke 10 mm.

Symmetric Style

Piping ports are provided on both the right and left hand sides. Switch rails and axial piping plates are interchangeable between the right and left hand side.

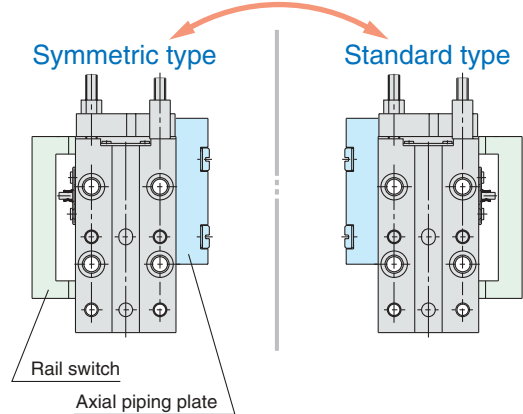

Variations

Model		Bore size (mm)	Standard stroke (mm)				Adjuster option			Piping option
Standard type	Symmetric type		5	10	15	20	Extension end	Retraction end	Both ends	Axial piping type
MXJ4	MXJ4L	4.5	●	●	—	—	●	●	●	●
MXJ6	MXJ6L	6	●	●	●	—	●	●	●	●
MXJ8	MXJ8L	8	●	●	●	●	●	●	●	●

Clean Specification

Clean specification products are available with no dimensional changes. The same options are available as for standard products.

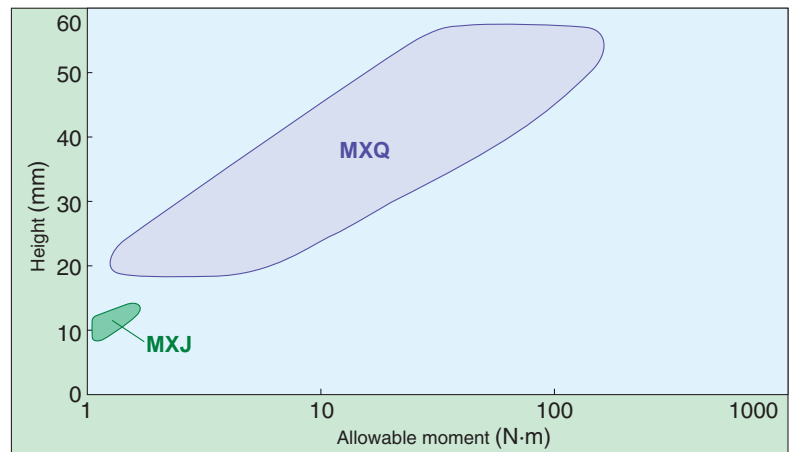
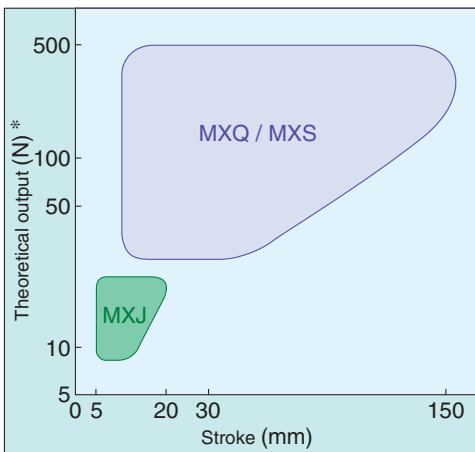

* Operating pressure: 0.5 MPa when operating direction is OUT.

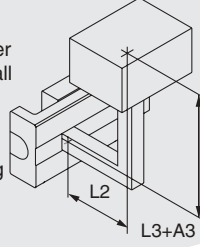
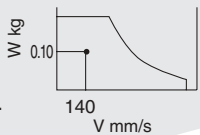
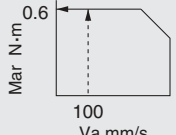
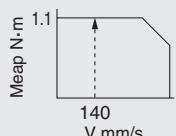
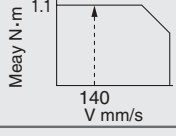

Series MXJ Model Selection

Model Selection Steps	Formula/Data	Selection Examples
<p>1 Operating Conditions</p> <p>List the operating conditions considering the mounting position and workpiece configuration.</p>	<ul style="list-style-type: none"> • Model to be used • Type of cushion • Mounting orientation • Average speed V_a (mm/s) • Load weight W (kg) • Overhang (mm) 	<p>Cylinder: MXJ6-10 Cushion: Rubber stopper Mounting: Horizontal wall mounting Average speed: $V_a = 100$ mm/s Load weight: $W = 0.1$ kg $L_2 = 40$ mm $L_3 = 50$ mm</p> 
<p>2 Load Weight</p> <p>Find the collision speed (mm/S)</p> <p>Confirm that the load weight W (kg) does not exceed the value in the graph.</p>	$V = \frac{1.4 \cdot V_a}{*}$ <p>* Correction factor (Reference value)</p> <p>Graph (1)</p>	<p>$V = 1.4 \times 100 = 140$</p> <p>Confirm that $V = 140$ and $W = 0.1$ do not exceed the values in Graph (1).</p> <p>Applicable because it does not exceed the value in Graph (1).</p> 
<p>3 Load Factor</p>		
<p>3-1 Load Factor of Static Moment</p> <p>Find the static moment M (N·m).</p> <p>Find the allowable static moment M_a (N·m).</p> <p>Find the load factor of the static moment.</p>	$M = W \times 9.8 (L_n + A_n)/1000$ <p>Corrected value of moment centre position distance A_n: Table (1)</p> <p>Pitch, Yaw moment: Graph (2) Roll moment: Graph (3)</p> $\alpha_1 = M/M_a$	<p>Examine M_r.</p> $M_r = 0.1 \times 9.8(40 + 3)/1000 = 0.042$ <p>$A_2 = 3$</p> <p>Obtain $M_{ar} = 0.6$ from $V_a = 100$ in Graph (3).</p> $\alpha_1 = 0.042/0.6 = 0.07$ 
<p>3-2 Load Factor of Dynamic Moment</p> <p>Find the dynamic moment M_e (N·m).</p> <p>Find the allowable dynamic moment M_{ea} (N·m) from graph.</p> <p>Find the load factor of the dynamic moment.</p>	$M_e = 1/3 \cdot W_e \times 9.8 (L_n + A_n)/1000$ <p>Weight equivalent to impact $W_e = \delta \cdot W \cdot V$ δ: Bumper coefficient Rubber stopper: 4/100 Metal stopper: 16/100</p> <p>Corrected value of moment centre position distance A_n: Table (1)</p> <p>Pitch, Yaw moment: Graph (2)</p> $\alpha_2 = M_e/M_{ea}$	<p>Examine M_{ep}.</p> $M_{ep} = 1/3 \times 0.56 \times 9.8 \times (40+3)/1000 = 0.078$ <p>$W_e = 4/100 \times 0.1 \times 140 = 0.56$</p> <p>$A_3 = 3$</p> <p>Obtain $M_{eap} = 1.1$ from $V = 140$ in Graph (2).</p> $\alpha_2 = 0.078/1.1 = 0.07$  <p>Examine M_{ey}.</p> $M_{ey} = 1/3 \times 0.56 \times 9.8 \times (50+11)/1000 = 0.116$ <p>$W_e = 0.56$</p> <p>$A_3 = 11$</p> <p>Obtain $M_{eay} = 1.1$ from $V = 140$ in Graph (2).</p> $\alpha_2' = 0.116/1.1 = 0.1$ 
<p>3-3 Sum of Load Factors</p> <p>Possible to use if the sum of the load factors does not exceed 1.</p>	$\alpha_1 + \alpha_2 < 1$	$\alpha_1 + \alpha_2 + \alpha_2' =$ <p>Applicable because</p> $0.07 + 0.07 + 0.1 = 0.24 < 1$

Series MXJ

Fig. (1) Overhang: L_n (mm), Correction Value of Moment Centre Position Distance: A_n (mm)

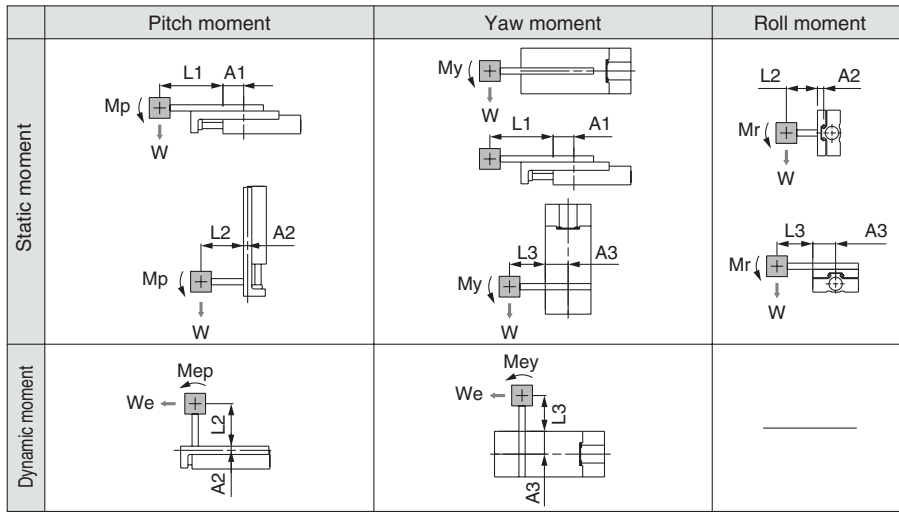

Note) Static moment: Moment generated by gravity
Dynamic moment: Moment generated by impact when colliding with stopper

Fig. (2) Allowable Static Load: F (N)

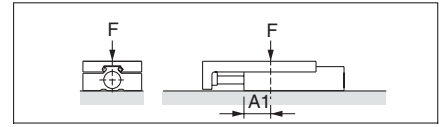

Graph (1) Load Weight: W
MXJ4

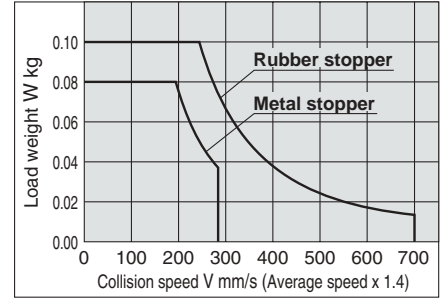

MXJ6

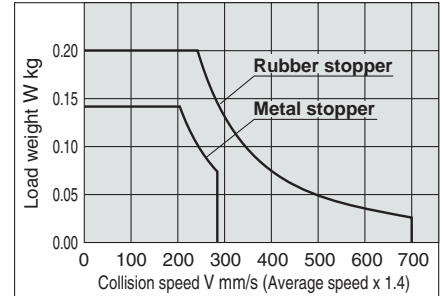

MXJ8

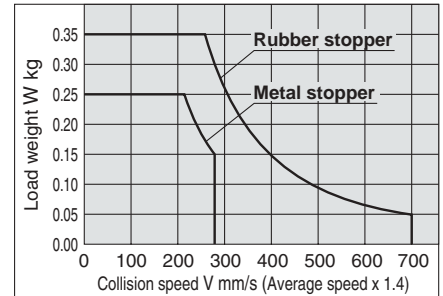
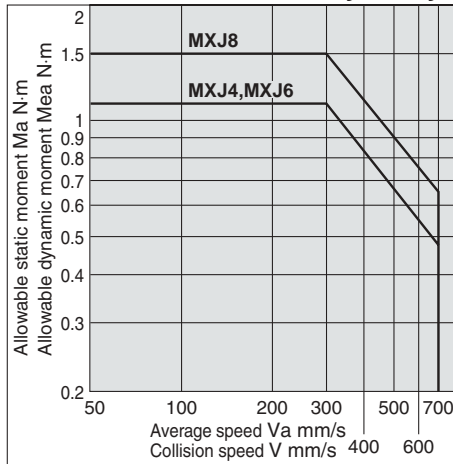

Table (4) Allowable Static Load: F (N)

Model	Allowable static load
MXJ4	300
MXJ6	300
MXJ8	500

The above value represents the applicable load at the position where the moment does not work at the time of stop. Factors such as impact, etc. are not in consideration with the value.

Graph (2) Allowable Moment
Pitch Moment: M_{ap} , M_{eap}
Yaw Moment: M_{ay} , M_{eay}



Note) Use the average speed when calculating static moment.
Use the collision speed when calculating dynamic moment.

Table (1) Correction Value of Moment Centre Position Distance: A_n (mm)

Model	Corrected value of moment centre position distance (Refer to Fig. 2.)		
	A1	A2	A3
MXJ4	10	3	10
MXJ6	10	3	11
MXJ8	12	4	13

Graph (3) Allowable Moment
Roll Moment: M_{ar}

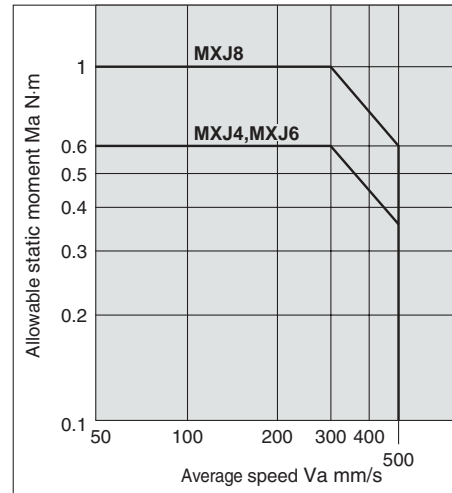

Table (2) Max. Allowable Load Weight: W_{max} (kg)

Model	Max. allowable load weight	
	Rubber stopper	Metal stopper
MXJ4	0.1	0.08
MXJ6	0.2	0.14
MXJ8	0.35	0.25

The above value represents the maximum value for each allowable load mass. For the maximum allowable load mass for each piston speed, please refer to Graph (1).

Table (3) Maximum Allowable Moment: M_{max} (N·m)

Model	Pitch/Yaw moment: M_{pmax}/M_{ymax}	Roll moment: M_{rmax}
MXJ4	1.1	0.6
MXJ6	1.1	0.6
MXJ8	1.5	1.0

The above value represents the maximum value of allowable moment. For the maximum allowable moment for each piston speed, please refer to Graph (2) and (3).

Symbol

Symbol	Definition	Unit	Symbol	Definition	Unit
A_n ($n = 1$ to 3)	Corrected value of moment centre position distance	mm	F	Allowable static load	N
L_n ($n = 1$ to 3)	Overhang	mm	V	Collision speed (Average speed x 1.4)	mm/s
M (M_p , M_y , M_r)	Static moment (pitch, yaw, roll)	N·m	V_a	Average speed	mm/s
M_a (M_{ap} , M_{ay} , M_{ar})	Allowable static moment (pitch, yaw, roll)	N·m	W	Load weight	kg
M_e (M_{ep} , M_{ey})	Dynamic moment (pitch, yaw)	N·m	W_a	Weight equivalent to impact	kg
M_{ea} (M_{eap} , M_{eay})	Allowable dynamic moment (pitch, yaw)	N·m	W_{max}	Max. allowable load weight	kg
M_{max} (M_{pmax} , M_{ymax} , M_{rmax})	Max. allowable moment (pitch, yaw, roll)	N·m	α	Load factor	—

Air Slide Table

Series MXJ

∅4.5, ∅6, ∅8

How to Order

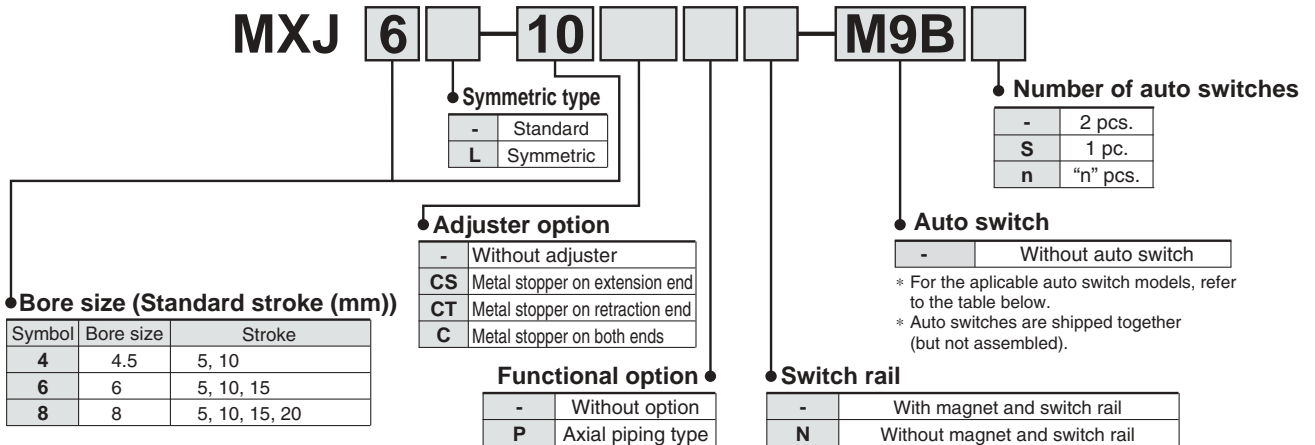

(Note) Use an optional stepped positioning pin (see page 5) because the positioning pin hole of this product goes through.

Applicable Auto Switches/Refer to page 16 through to 21 for further information on auto switches.

Type	Special function	Electrical entry	Indicator light	Wiring (Output)	Load voltage		Auto switch model		Lead wire length*(m)			Pre-wired connector	Applicable load		
					DC	AC	Electrical entry direction	In-line	0.5 (Nil)	3 (L)	5 (Z)		IC circuit	Relay, PLC	
Reed switch	—	Grommet	Yes	3-wire (NPN equivalent)	—	5 V	—	A96V	A96	●	●	—	—	IC circuit	—
				2-wire	24 V	12 V	100 V	A93V	A93	●	●	—	—	—	Relay, PLC
					5 V, 12 V	100 V or less	A90V	A90	●	●	—	—	—	IC circuit	—
Solid state switch	—	Grommet	Yes	3-wire (NPN)	24 V	5 V	—	M9NV	M9N	●	●	○	○	IC circuit	Relay, PLC
				3-wire (PNP)		12 V		M9PV	M9P	●	●	○	○		
				2-wire		12 V		M9BV	M9B	●	●	○	○	—	
				3-wire (NPN)		5 V		F8N	—	●	●	○	—	IC circuit	
				3-wire (PNP)		12 V				●	●	○		—	
				2-wire		12 V		F8B	—	●	●	○	—	—	
				3-wire (NPN)		5 V		F9NWV	F9NW	●	●	○	○	IC circuit	
				3-wire (PNP)		12 V		F9PWV	F9PW	●	●	○	○	—	
				2-wire		12 V		F9BWV	F9BW	●	●	○	○	—	

* Lead wire length symbols: 0.5 m..... Nil (Example) M9N
3 m..... L (Example) M9NL
5 m..... Z (Example) M9NZ

* Solid state switches marked with "○" are produced upon receipt of order.

* Solid state switches marked with "○" are produced upon receipt of order.
* For details on auto switches with a pre-wired connector, refer to "SMC Best Pneumatics" catalogue.

Caution
When an auto switch is not mounted properly, it can cause a malfunction. Refer to page 15 "Auto Switch Mounting".

Clean Series

11—MXJ Standard model no.

● Clean Series
11: Vacuum type * External dimensions are identical to the standard model.

Model

Model	Adjuster option	Grade	Intake flow (ℓ/min) (ANR)*
11-MXJ4(L)	Without adjuster	Grade 3 (Class 100 or equivalent)	1
	Metal stopper	Grade 4 (Class 1000 or equivalent)	
11-MXJ6(L)	Without adjuster	Grade 3 (Class 100 or equivalent)	
	Metal stopper	Grade 4 (Class 1000 or equivalent)	
11-MXJ8(L)	Without adjuster	Grade 3 (Class 100 or equivalent)	
	Metal stopper	Grade 4 (Class 1000 or equivalent)	

* Reference value

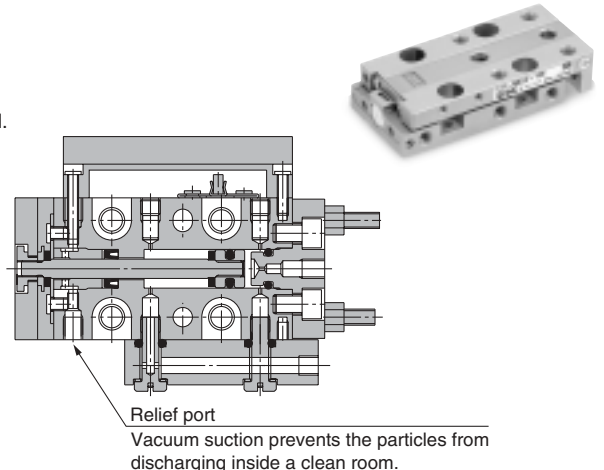

Series MXJ



Specifications

Model	MXJ4	MXJ6	MXJ8
Bore size (mm)	4.5	6	8
Piping port size	M3		
Fluid	Air		
Action	Double acting		
Operating pressure	0.15 to 0.7 MPa		
Proof pressure	1.05 MPa		
Ambient and fluid temperature	-10 to 60°C		
Operating speed range	50 to 500 mm/s (Metal stopper: 50 to 200 mm/s)		
Cushion	Rubber bumper (Metal stopper: Without cushion)		
Lubrication	Non-lube		
Stroke adjuster	Standard equipment		
Stroke adjusting range (metal stopper)	Both ends each 0 to 5 mm		
Auto switch	Reed switch (2-wire, 3-wire) Solid state switch (2-wire, 3-wire) 2-colour indication solid state switch (2-wire, 3-wire)		
Stroke length tolerance	+1 0 mm		

Standard Stroke

Model	Standard stroke (mm)
MXJ4	5, 10
MXJ6	5, 10, 15
MXJ8	5, 10, 15, 20

Option

Adjuster option	Metal stopper	Extension end (CS)	Stroke adjustment range 0 to 5 mm
		Retraction end (CT)	
		Both ends (C)	
Functional option	Axial piping type (P)		Stroke adjuster is mountable on the axial piping.

Theoretical Output

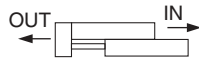

Model	Bore size (mm)	Rod size (mm)	Operating direction	Piston area (mm ²)	Operating pressure (MPa)					
					0.2	0.3	0.4	0.5	0.6	0.7
MXJ4	4.5	2	OUT	16	3	5	6	8	10	11
			IN	13	3	4	5	6	8	9
MXJ6	6	3	OUT	28	6	8	11	14	17	20
			IN	21	4	6	8	11	13	15
MXJ8	8	4	OUT	50	10	15	20	25	30	35
			IN	38	8	11	15	19	23	26

Note) Theoretical output (N) = Pressure (MPa) x Piston area (mm²)

Weight

Basic Style (Without switch rail) MXJ□□-□□N

(g)

Model	Standard stroke (mm)				Additional weight of adjuster option	
	5	10	15	20	Extension end	Retraction end
MXJ4	40	40	—	—	2	6
MXJ6	50	50	55	—	2	8
MXJ8	70	70	90	90	2	12

Axial Piping Type (Without switch rail) MXJ□□-□□PN

(g)

Model	Standard stroke (mm)				Additional weight of adjuster option	
	5	10	15	20	Extension end	Retraction end
MXJ4	50	50	—	—	2	6
MXJ6	60	60	65	—	2	8
MXJ8	85	85	110	110	2	12

Additional Weight of Switch Rail

(g)

Model	Standard stroke (mm)			
	5	10	15	20
MXJ4	5	5	—	—
MXJ6	5	5	6	—
MXJ8	5	5	7	7

Table Accuracy

B side parallelism to A side	0.03
B side traveling parallelism to A side	0.005
C side perpendicularity to A side	0.01
M dimension tolerance	± 0.05
Radial clearance (μm)	0 (Note)
Non-rotating table accuracy (deg)	0 (Note)

Note) In theory, radial clearance and non-rotating table accuracy are zero by the preloaded specification. However, in some actual cases, a moment can be applied and can cause deflection in an individual part. Therefore, refer to the table displacement amount on page 6.

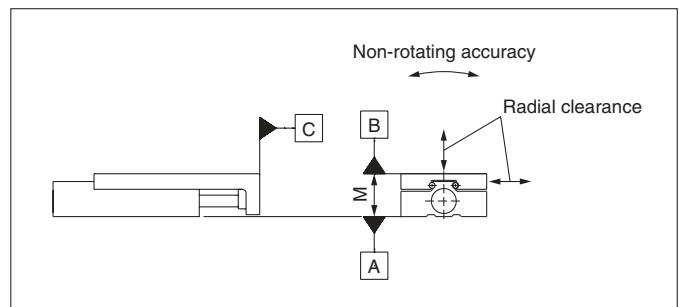

Optional Specifications

Rail assembly for mounting auto switch

When auto switch is mounted on air slide table without rail (MXP□-□N), this assembly is used.

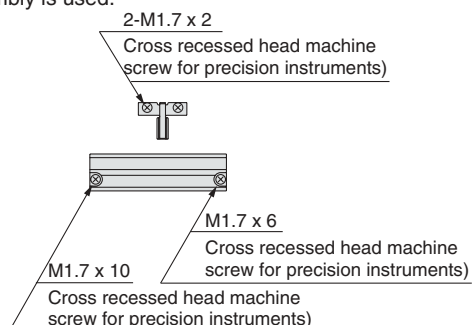

Applicable size	Switch rail part no.	Note
MXJ4-5	MXJ-AD4-10	With magnet and mounting screw
MXJ4-10		
MXJ6-5	MXJ-AD6-10	
MXJ6-10		
MXJ6-15	MXJ-AD6-15	
MXJ8-5	MXJ-AD6-10	
MXJ8-10		
MXJ8-15	MXJ-AD8-20	
MXJ8-20		

Stepped positioning pin

MXJ-LP

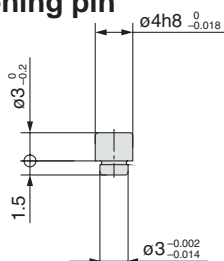

Use the optional stepped positioning pin that is provided because the positioning pin hole for the table is a through hole.

Stepped Positioning Pin

Part no.	Note
MXJ-LP	Common for all models

Table Deflection (Reference values)

Table displacement due to pitch moment load

Deflection at the arrow mark when a load is applied to the arrow mark with the slide table fully extended.

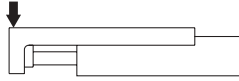

MXJ4

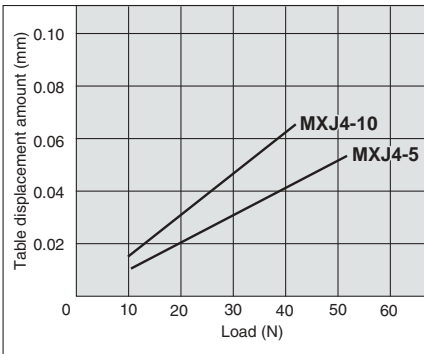

MXJ6

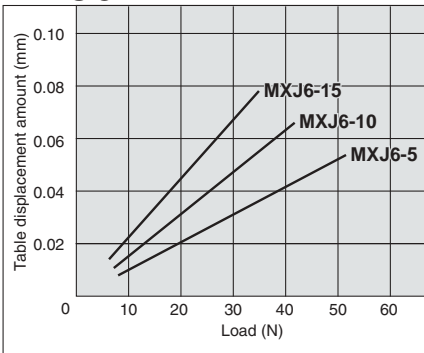

MXJ8

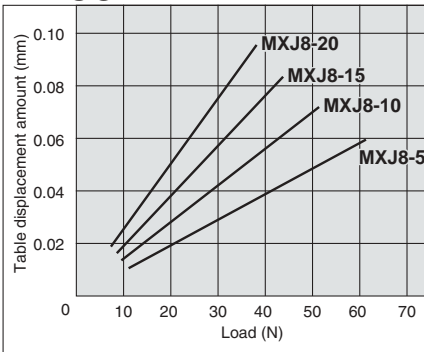
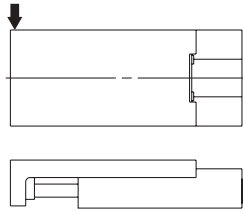
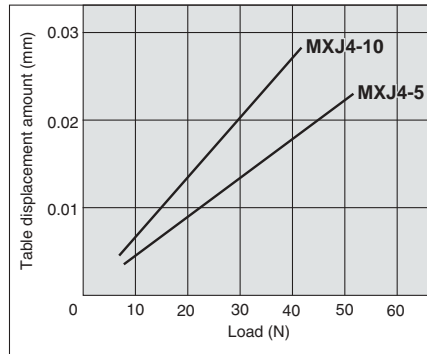

Table displacement due to yaw moment load

Deflection at the arrow mark when a load is applied to the arrow mark with the slide table fully extended.



MXJ4



MXJ6

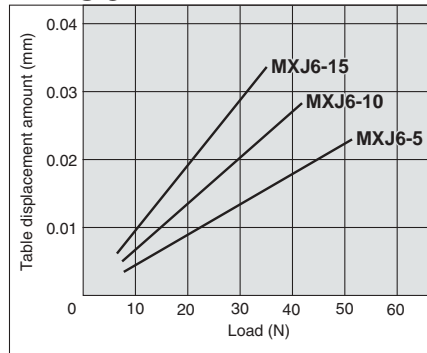

MXJ8

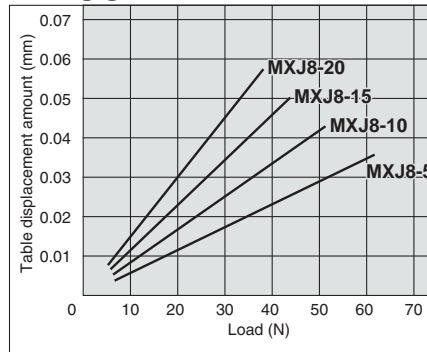
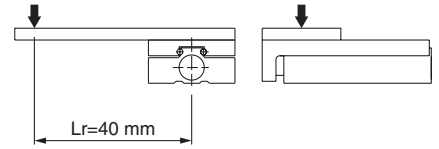
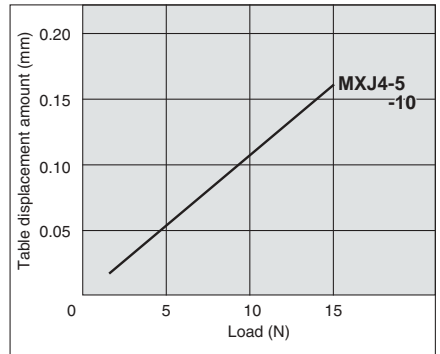

Table displacement due to roll moment load

Displacement at "A" when a load is applied to "F" with the slide table retracted.



MXJ4



MXJ6

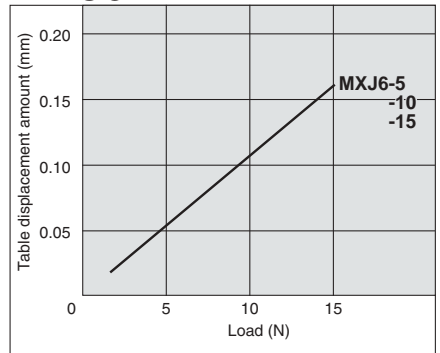

MXJ8

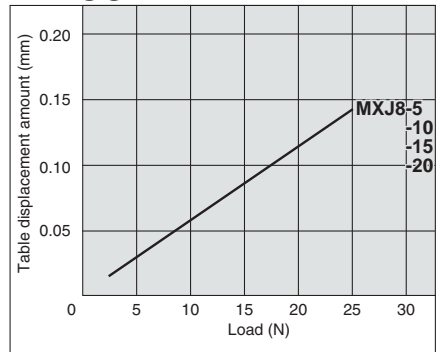

Dimensions Note) In MXJ4, there is no change in total length by stroke.

Basic style (Without switch rail)

MXJ4-□□□N

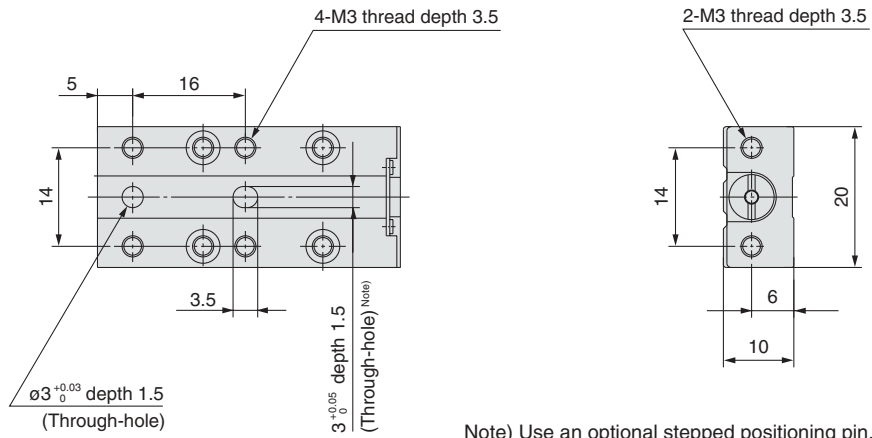

Note) Use an optional stepped positioning pin. (See page 5.)

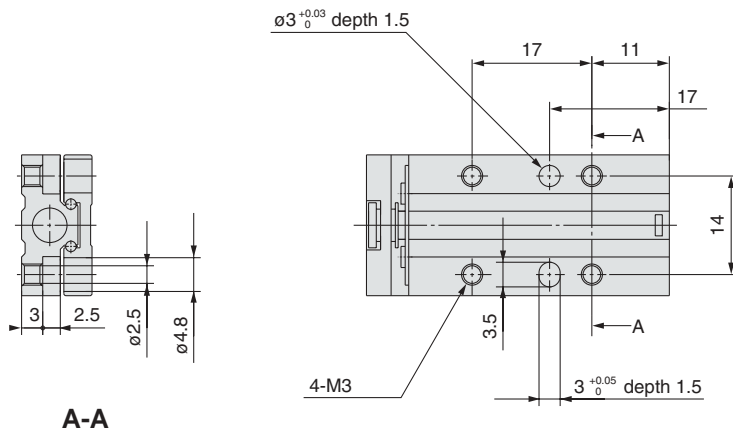
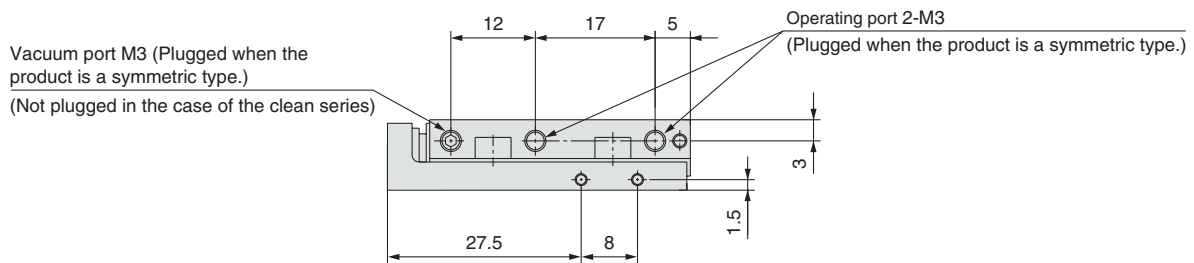

A-A

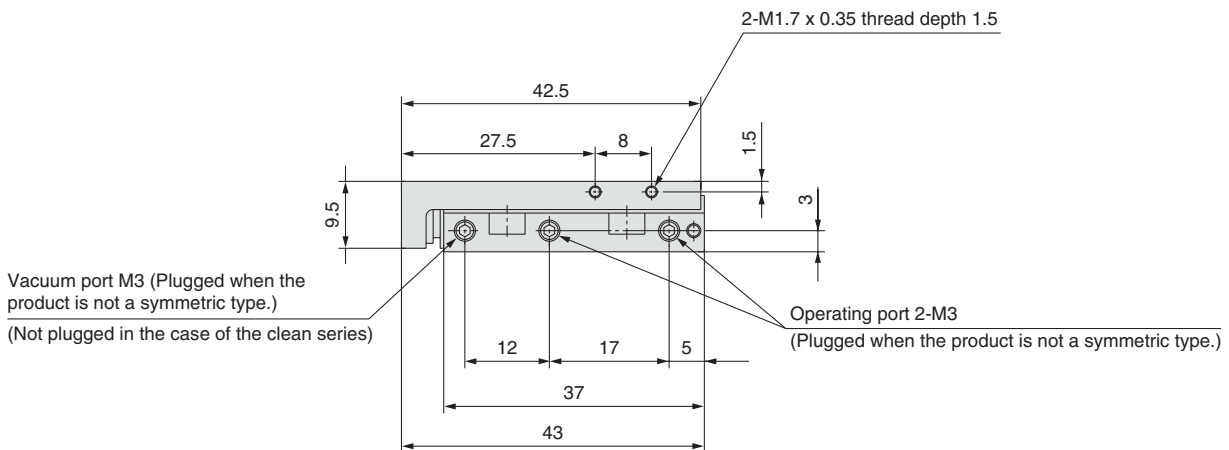

Series MXJ

Dimensions

With stroke adjuster

With adjuster on both ends

MXJ4-□C□N

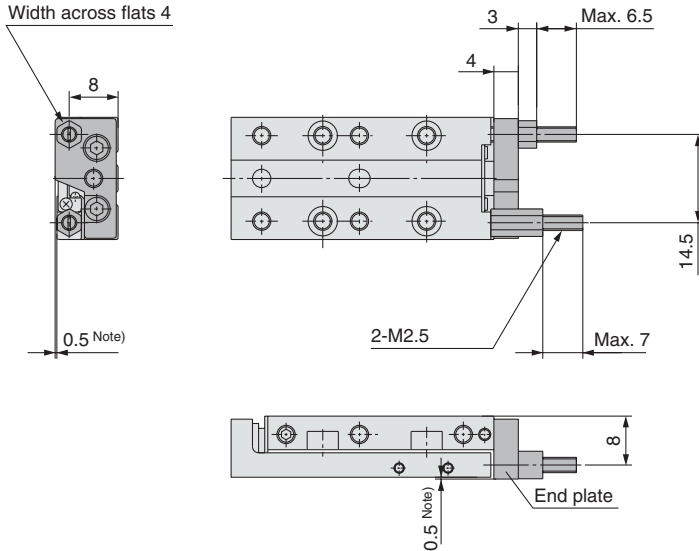

With adjuster on extension end

MXJ4-□CSN

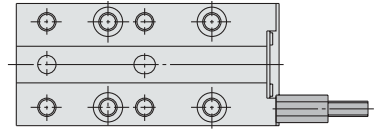

With adjuster on retraction end

MXJ4-□CTN

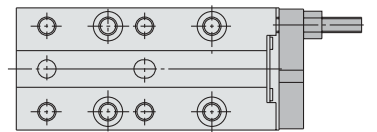

Note) Use caution because the height of the end plate's top surface will be higher than the table's top surface.

Axial piping

MXJ4-□□PN

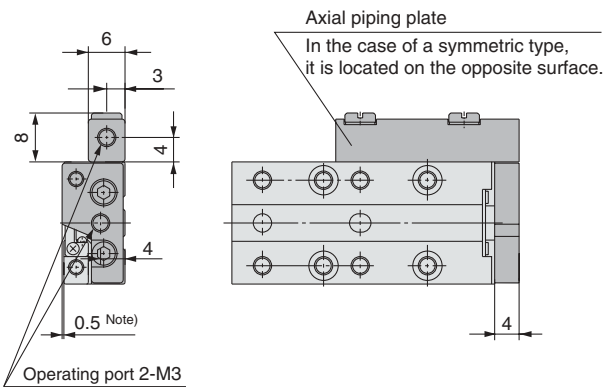

With switch rail

MXJ4

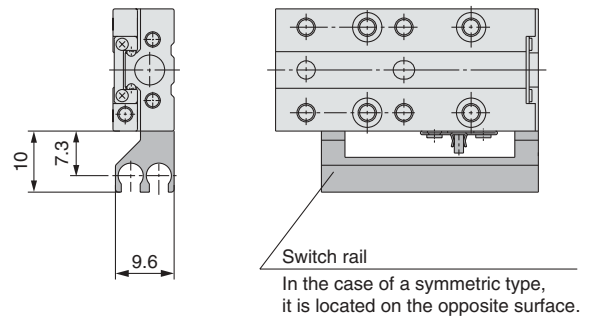

Note) Use caution because the height of the end plate's top surface will be higher than the table's top surface.

When all the available options are mounted (switch rail, stroke adjuster, with axial piping).

Standard type

MXJ4-□CP

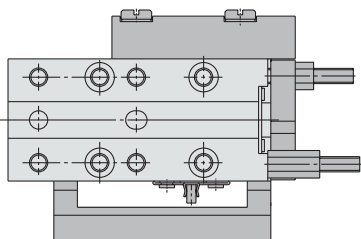

Symmetric type

MXJ4L-□CP

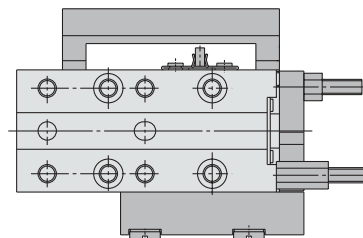

Dimensions Note) In MXJ4, there is no change in total length by stroke.

Basic style (Without switch rail)

MXJ6-□□□N

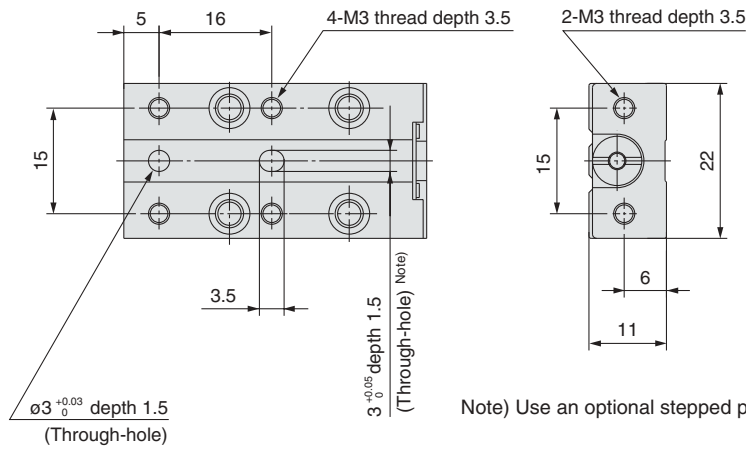

Note) Use an optional stepped positioning pin. (See page 5.)

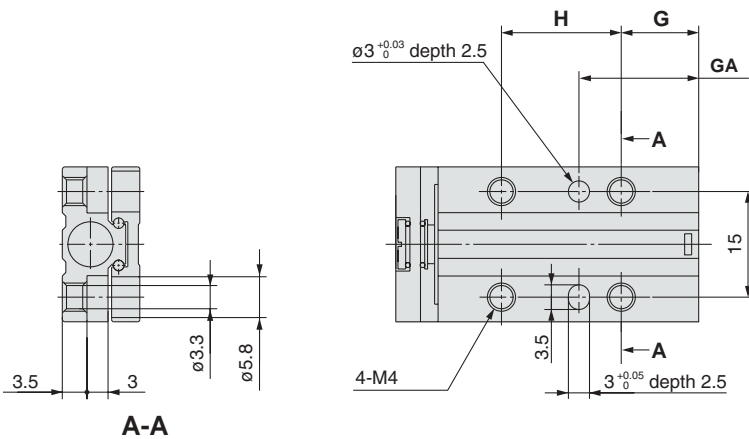
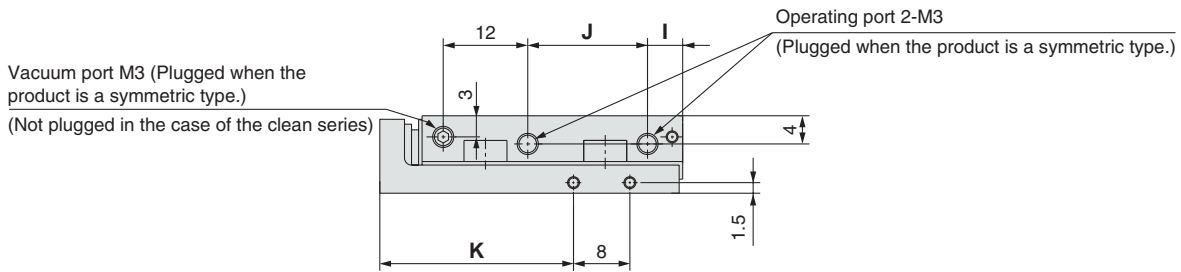

A-A

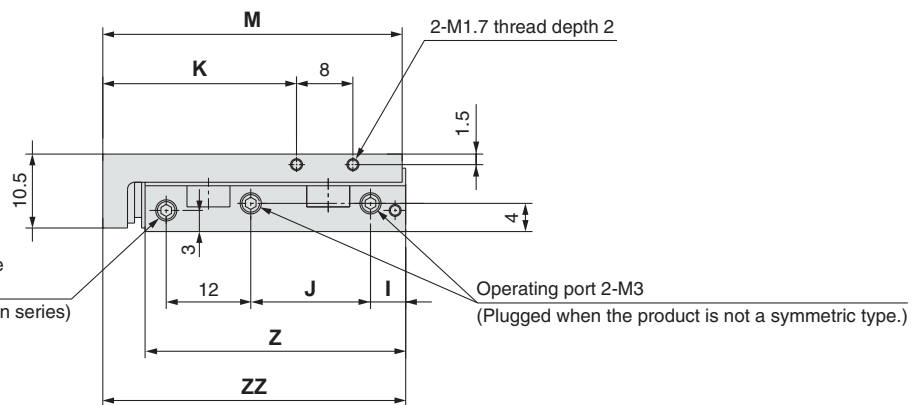

Model	G	GA	H	I	J	K	M	Z	ZZ
MXJ6-5	11	17	17	5	17	27.5	42.5	37	43
MXJ6-10	11	17	17	5	17	27.5	42.5	37	43
MXJ6-15	13	22	20	7	20	31.5	47.5	42	48

Series MXJ

Dimensions

With stroke adjuster
With adjuster on both ends
MXJ6-□C□N

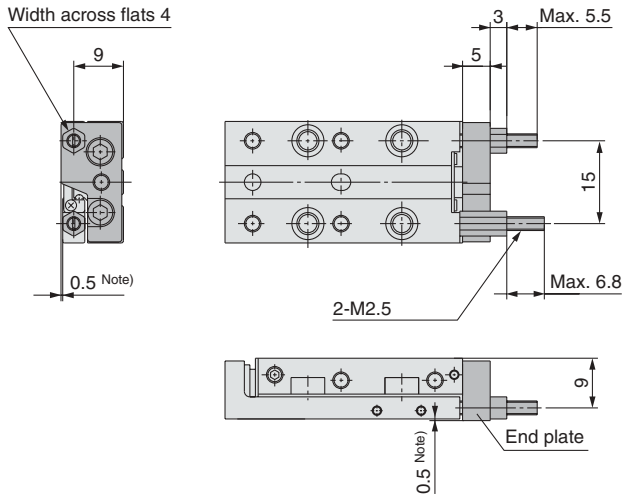

With adjuster on extension end
MXJ6-□CS□N

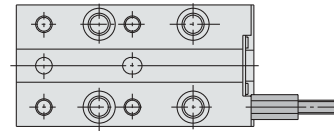

With adjuster on retraction end
MXJ6-□□CTN

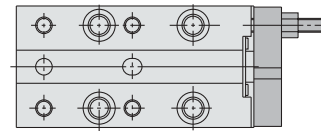

Note) Use caution because the height of the end plate's top surface will be higher than the table's top surface.

Axial piping
MXJ6-□□PN

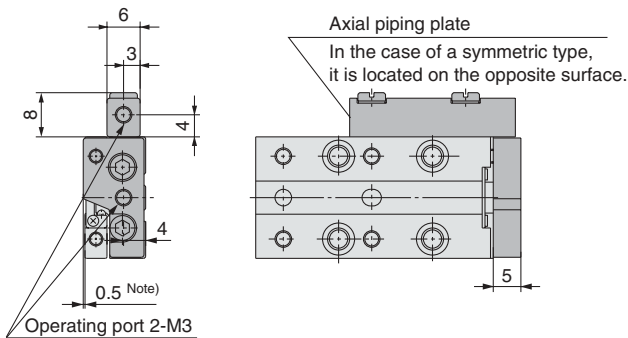

With switch rail
MXJ6

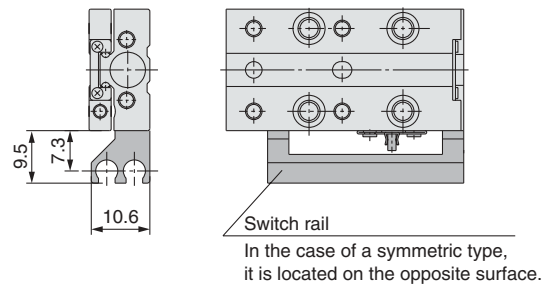

Note) Use caution because the height of the end plate's top surface will be higher than the table's top surface.

When all the available options are mounted (switch rail, stroke adjuster, with axial piping)

Standard type
MXJ6-□CP

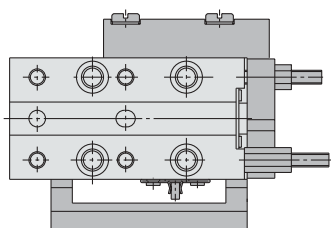

Symmetric type
MXJ6L-□CP

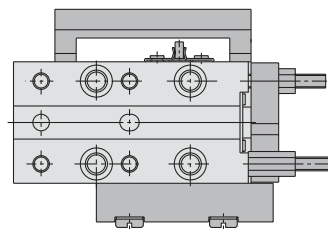

Dimensions

Basic style (Without switch rail)
MXJ8-□□□N

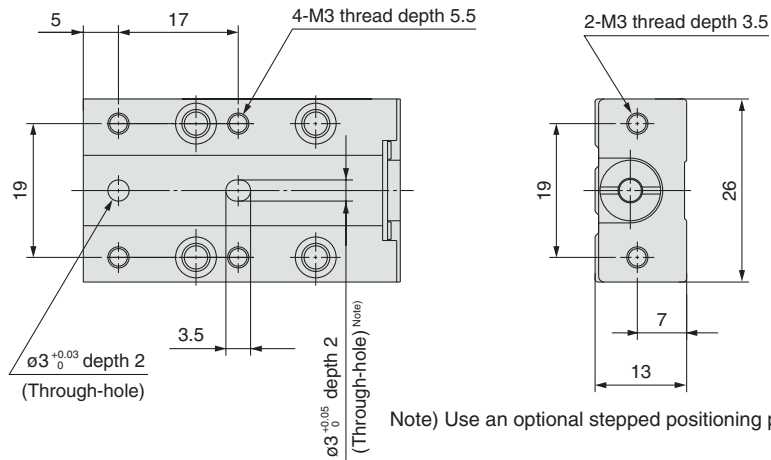

Note) Use an optional stepped positioning pin. (See page 5.)

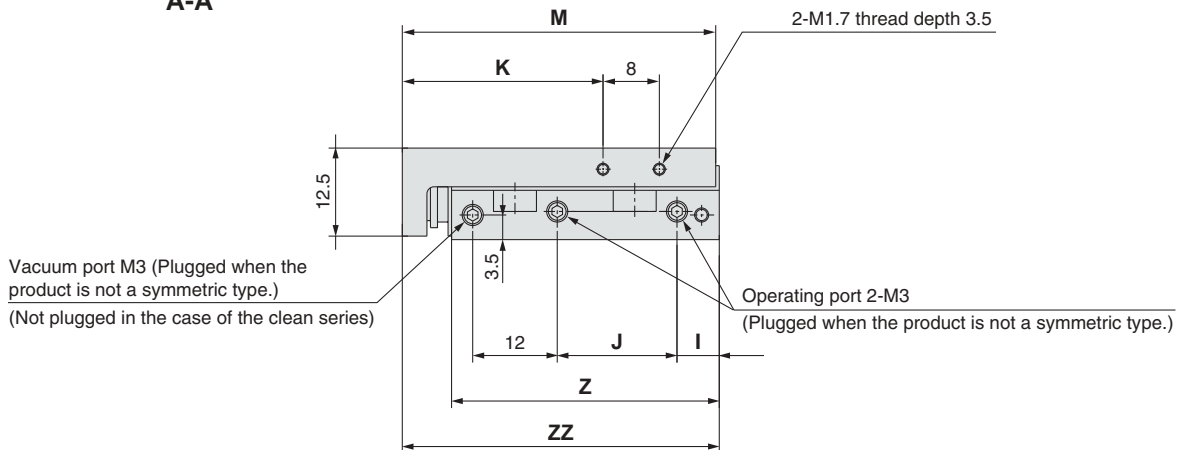
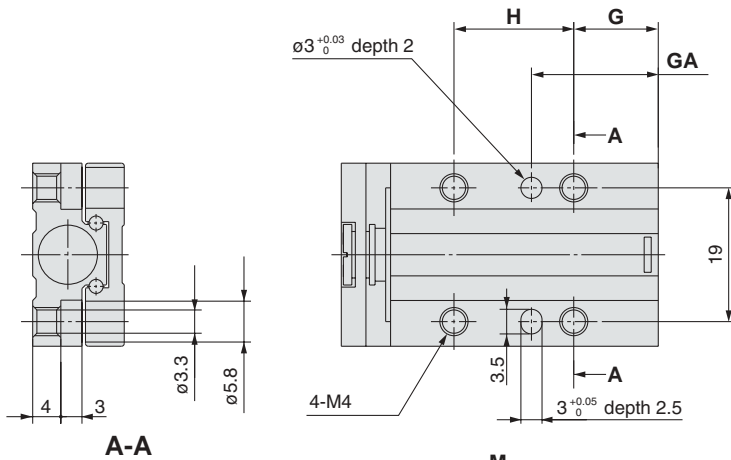
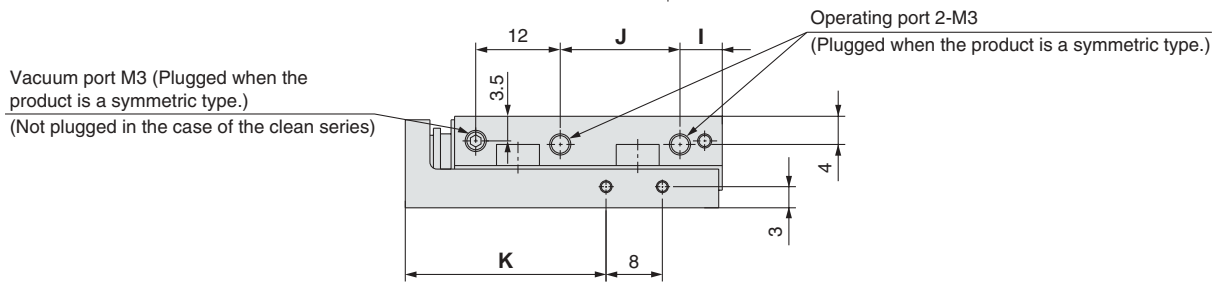

Model	G	GA	H	I	J	K	M	Z	ZZ
MXJ8-5	12	18	17	6	17	28.5	44.5	38	45
MXJ8-10	12	18	17	6	17	28.5	44.5	38	45
MXJ8-15	19	28	20	8	25	39.5	54.5	48	55
MXJ8-20	19	28	20	8	25	39.5	54.5	48	55

Series MXJ

Dimensions

With stroke adjuster

With adjuster on both ends

MXJ8-□C□N

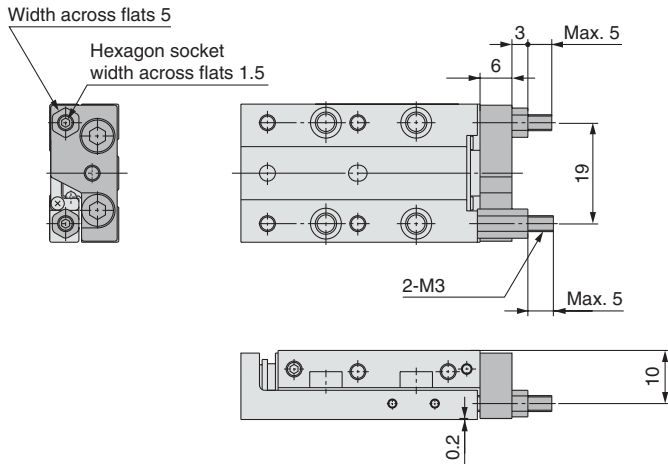

With adjuster on extension end

MXJ8-□CS□N

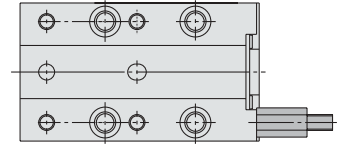

With adjuster on retraction end

MXJ8-□CTN

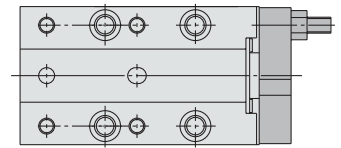

Axial piping

MXJ8-□□PN

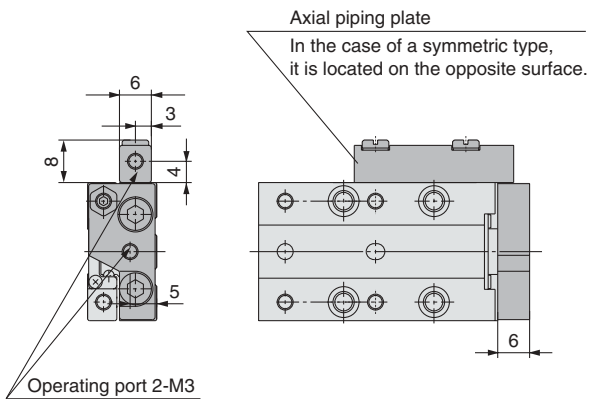

With switch rail

MXJ8

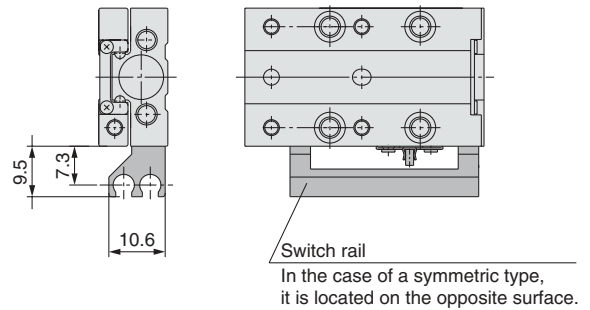

When all the available options are mounted (switch rail, stroke adjuster, with axial piping)

Standard type
MXJ8-□CP

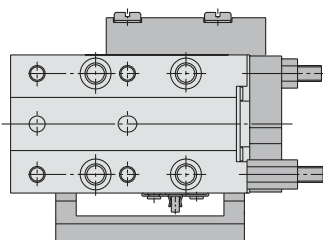

Symmetric type
MXJ8L-□CP

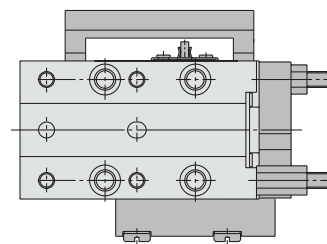

Construction

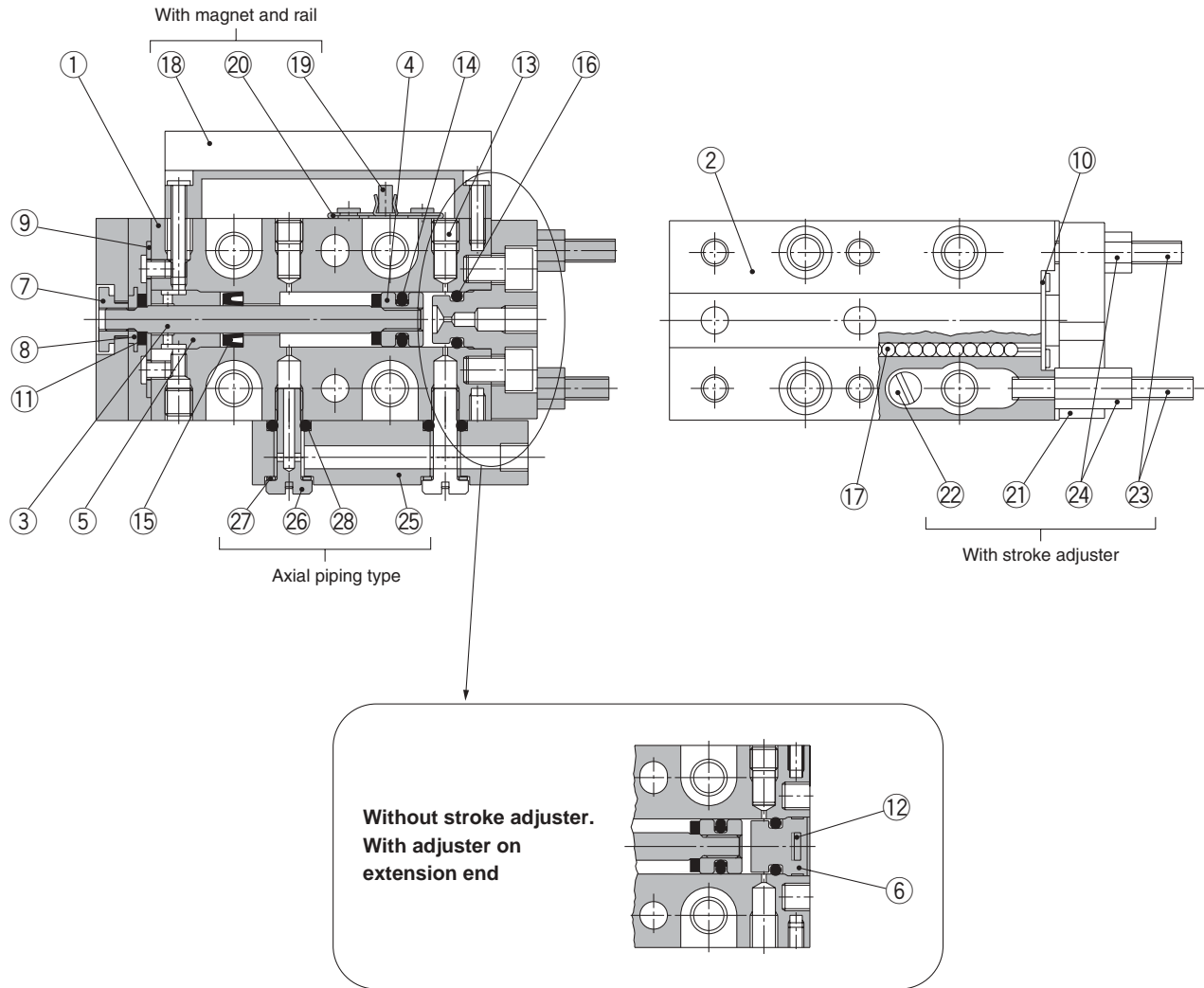

Component Parts

No.	Description	Material	Note
1	Body	Martensitic stainless steel ^{Note)}	Heat treated
2	Table	Martensitic stainless steel ^{Note)}	Heat treated
3	Rod	Stainless steel	
4	Piston	Brass	Electroless nickel plated
5	Rod cover	Resin	
6	Head cap	Resin	
7	Floating bushing A	Stainless steel	
8	Floating bushing B	Stainless steel	
9	Roller stopper A	Stainless steel	
10	Roller stopper B	Stainless steel	
11	Rod bumper	Polyurethane	
12	Plate	Stainless steel	
13	Plug	Steel + Fluorine	Nickel plated
14	Piston seal	NBR	
15	Rod seal	NBR	
16	O-ring	NBR	
17	Steel balls	High carbon chrome bearing steel	

Note) Use caution because the martensitic stainless steel is inferior in corrosiveness when compared with austenitic stainless steel.

Component Parts: With Magnet, Rail

No.	Description	Material	Note
18	Switch rail	Aluminum alloy	Hard anodized
19	Magnet	Rare earth	
20	Magnet holder	Stainless steel	

Component Parts: With Stroke Adjuster

No.	Description	Material	Note
21	End plate	Stainless steel	
22	Stopper pin	Steel	Heat treated, Trivalent chromated
23	Adjustment bolt	Steel	Heat treated, Nickel plated
24	Adjustment nut	Steel	Nickel plated

Component Parts: Axial Piping Type

No.	Description	Material	Note
25	Axial piping plate	Aluminum alloy	Hard anodized
26	Stud	Brass	Electroless nickel plated
27	Gasket	Stainless steel + NBR	
28	O-ring	NBR	

Proper Position for Auto Switch Mounting (Detection at stroke end)

Reed switch
D-A9□

Solid state switch
D-M9□
D-F9□W

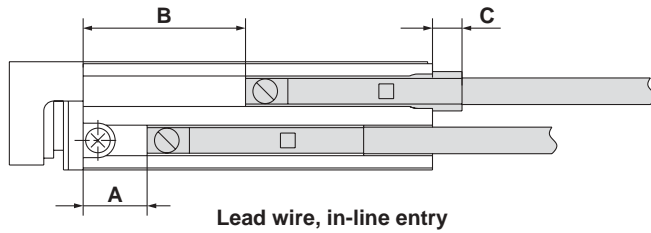

* Figures in the table above are used as a reference when mounting the auto switches for stroke end detection. In the case of actually setting the auto switches, adjust them after confirming their operation.

Reed Switch: D-A9□

(mm)

Model	A				B				C			
	Stroke				Stroke				Stroke			
	5	10	15	20	5	10	15	20	5	10	15	20
MXJ4	9	4	—	—	14	14	—	—	0.5	0.5	—	—
MXJ6	9	4	3	—	14	14	18	—	0.5	0.5	-0.5	—
MXJ8	9	4	10	5	14	14	25	25	-0.5	-0.5	0.5	0.5

Solid State Switch, 2-colour Indication Solid State Switch: D-M9□, D-F9□W

(mm)

Model	A				B				C			
	Stroke				Stroke				Stroke			
	5	10	15	20	5	10	15	20	5	10	15	20
MXJ4	13	8	—	—	18	18	—	—	4.5	4.5	—	—
MXJ6	13	8	7	—	18	18	22	—	4.5	4.5	3.5	—
MXJ8	13	8	14	9	18	18	29	29	3.5	3.5	4.5	4.5

Reed switch
D-A9□V

Solid state switch
D-M9□V
D-F9□WV
D-F8□

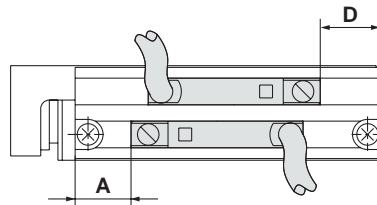

* Figures in the table above are used as a reference when mounting the auto switches for stroke end detection. In the case of actually setting the auto switches, adjust them after confirming their operation.

Reed Switch: D-A9□V

(mm)

Model	A				D			
	Stroke				Stroke			
	5	10	15	20	5	10	15	20
MXJ4	9	4	—	—	1.5	1.5	—	—
MXJ6	9	4	3	—	1.5	1.5	2.5	—
MXJ8	9	4	10	5	2.5	2.5	1.5	1.5

Solid State Switch, 2-colour Indication Solid State Switch: D-M9□V, D-F9□WV

(mm)

Model	A				D			
	Stroke				Stroke			
	5	10	15	20	5	10	15	20
MXJ4	13	8	—	—	5.5	5.5	—	—
MXJ6	13	8	7	—	5.5	5.5	6.5	—
MXJ8	13	8	14	9	6.5	6.5	5.5	5.5

Solid State Switch: D-F8□

(mm)

Model	A				D			
	Stroke				Stroke			
	5	10	15	20	5	10	15	20
MXJ4	11	6	—	—	3.5	3.5	—	—
MXJ6	11	6	5	—	3.5	3.5	4.5	—
MXJ8	11	6	12	7	4.5	4.5	3.5	3.5

Operating Range

Auto switch model	Applicable bore size (mm)
D-A9□/A9□V	4
D-M9□/M9□V	2
D-F8□	2
D-F9W□/F9W□V	2.5

* The operating range is a reference value including hysteresis, but is not guaranteed. This may vary substantially depending on the surrounding environment (assuming approximately 30% dispersion).

Auto Switch Mounting

⚠ Caution

Auto Switch Mounting Tool

- When tightening the auto switch mounting screw (included with the auto switch), use a watchmakers' screwdriver with a handle about 5 to 6 mm in diameter.

Tightening Torque

- Use a torque of 0.10 to 0.20 N·m.

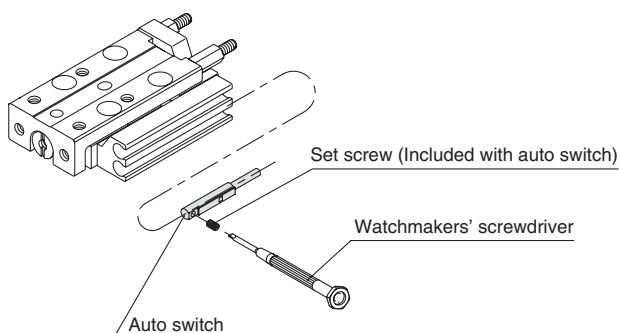

When using the following solid state switches (D-M9□(V), F9□W(V), F8□), mount them in the illustrated direction. The lower slot is for extension end detection.

• Lead wire, in-line entry (D-M9□, F9□W)

Extension end Retraction end

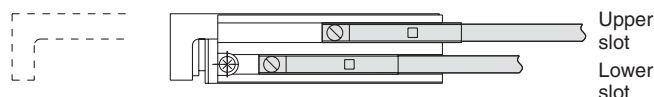

• Lead wire, perpendicular entry (D-M9□V, F9□WV, F8□)

Extension end Retraction end

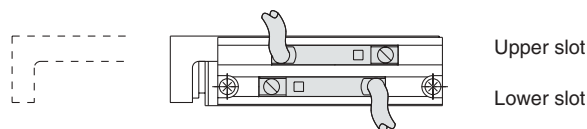

Caution on handling symmetric type

⚠ Caution

- Maintain a minimum space if standard type and symmetric type are used side by side.

If the space is insufficient, it may cause auto switches to malfunction.

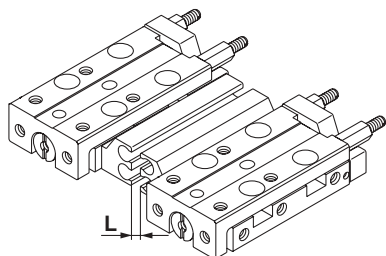

L Dimension

Without shielding plate	8 mm
With shielding plate	3 mm

Placing a shield plate (0.2 to 0.3 mm iron plate) in between the products allows the distance to be smaller.

Other than the applicable auto switches listed in "How to Order", the following auto switches can be mounted. For detailed specifications, refer to "SMC Best Pneumatics" catalogue.

Type	Model	Electrical entry (direction)	Output	Features
Reed switch	D-F9G	Grommet (In-line)	NPN	Normally closed (NC=b contact)
	D-F9H		PNP	

Auto Switch Specifications

Auto Switch Common Specifications

Type	Reed switch	Solid state switch
Leakage current	None	3-wire: 100 μ A or less 2-wire: 0.8 mA or less
Operating time	1.2 ms	1 ms or less
Impact resistance	300 m/s ²	1000 m/s ²
Insulation resistance	50 M Ω or more at 500 VDC Mega (between lead wire and case)	
Withstand voltage	1000 VAC for 1 minute (between lead wire and case)	
Ambient temperature	-10 to 60°C	
Enclosure	IEC529 standard IP67, JIS C 0920 waterproof construction	

Lead Wire Length

Lead wire length indication

(Example) **D-M9P****L**

Lead wire length

Nil	0.5 m
L	3 m
Z	5 m

Note 1) Applicable auto switch with 5 m lead wire "Z"

Reed switch: None

Solid state switch: Manufactured upon receipt of order as standard.

Note 2) To designate solid state switches with flexible specifications, add "-61" after the lead wire length.

* Oilproof flexible heavy-duty cable is used for D-M9□ as standard. There is no need to add the suffix -61 to the end of part number.

(Example) **D-F9PWVL-61**

Flexible specification

Auto Switch Hysteresis

The hysteresis is the difference between the position of the auto switch as it turns "on" and as it turns "off". A part of operating range (one side) includes this hysteresis.

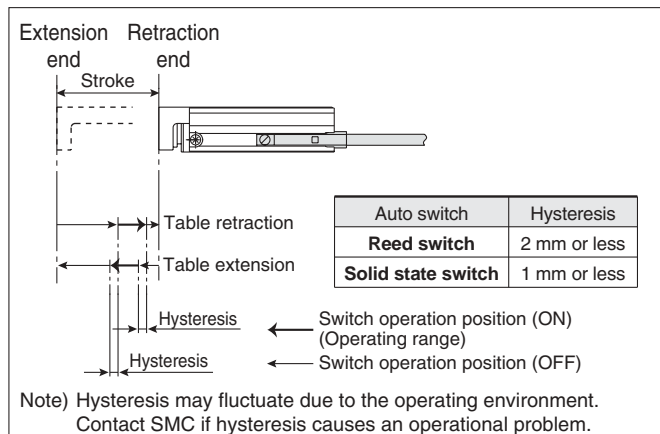

Contact Protection Boxes: CD-P11, CD-P12

<Applicable switch model>

D-A9/A9□V

The auto switches above do not have a built-in contact protection circuit. Therefore, please use a contact protection box with the switch for any of the following cases:

- ① Where the operation load is an inductive load.
- ② Where the wiring length to load is greater than 5 m.
- ③ Where the load voltage is 100 VAC.

The contact life may be shortened. (Due to permanent energising conditions.)

Specifications

Part no.	CD-P11		CD-P12
Load voltage	100 VAC	200 VAC	24 VDC
Maximum load current	25 mA	12.5 mA	50 mA

* Lead wire length — Switch connection side 0.5 m
Load connection side 0.5 m



Internal Circuit

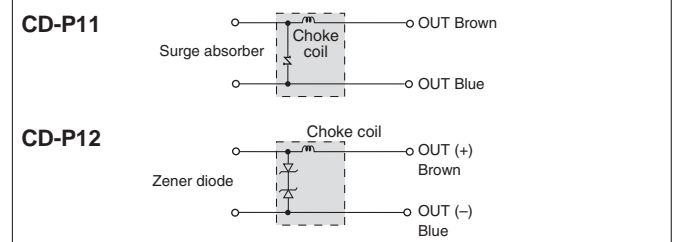

Dimensions

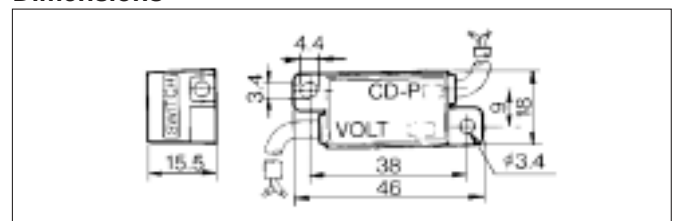

Connection

To connect a switch unit to a contact protection box, connect the lead wire from the side of the contact protection box marked SWITCH to the lead wire coming out of the switch unit. Keep the switch as close as possible to the contact protection box, with a lead wire length of no more than 1 metre.

Auto Switch Connections and Examples

Basic Wiring

Solid state 3-wire, NPN

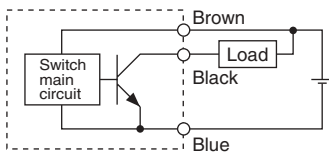

Solid state 3-wire, PNP

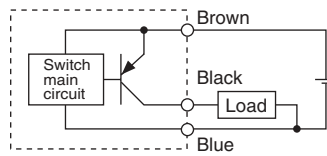

2-wire (Solid state)

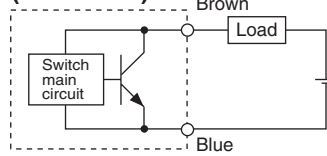

2-wire (Reed switch)

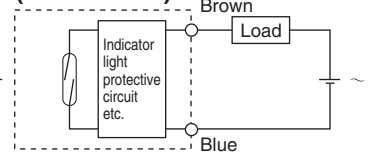

(Power supplies for switch and load are separate.)

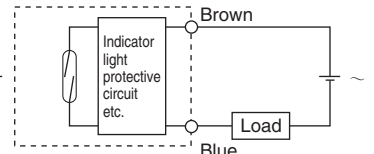
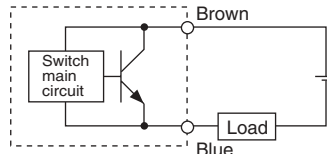
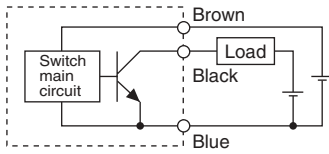

Example of Connection to PLC (Programmable Logic Controller)

• Sink input specifications 3-wire, NPN

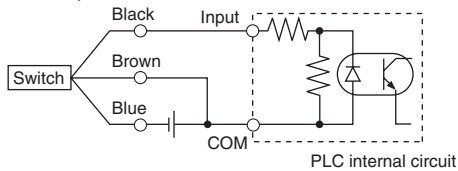

• Source input specifications 3-wire, PNP

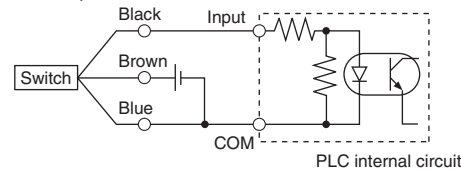

Connect according to the applicable PLC input specifications, since the connection method will vary depending on the PLC input specifications.

2-wire

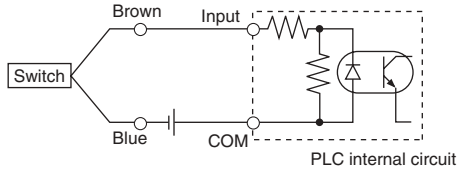

2-wire

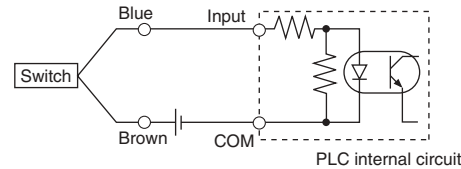

Example of AND (Serial) and OR (Parallel) Connection

• 3-wire

AND connection for NPN output (using relays)

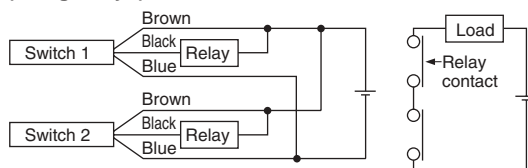

AND connection for NPN output (performed with switches only)

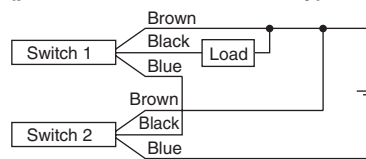

OR connection for NPN output

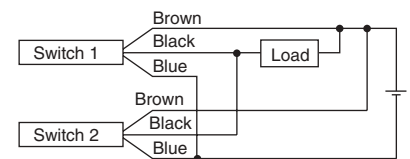

The indicator lights will illuminate when both switches are turned ON.

2-wire with 2-switch AND connection

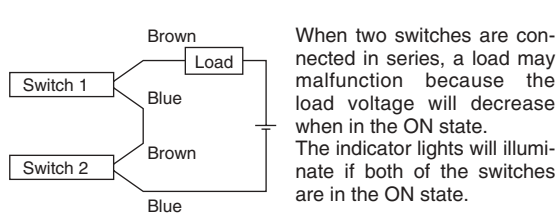

$$\begin{aligned} \text{Load voltage at ON} &= \text{Power supply voltage} - \text{Internal voltage drop} \times 2 \text{ pcs.} \\ &= 24 \text{ V} - 4 \text{ V} \times 2 \text{ pcs.} \\ &= 16 \text{ V} \end{aligned}$$

Example: Power supply is 24 VDC.
Internal voltage drop in switch is 4 V.

2-wire with 2-switch OR connection

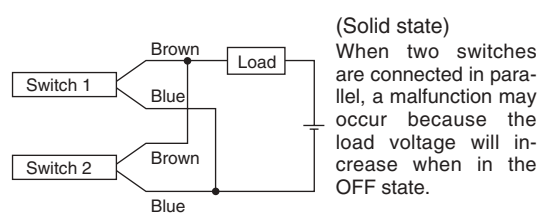

$$\begin{aligned} \text{Load voltage at OFF} &= \text{Leakage current} \times 2 \text{ pcs.} \\ &\quad \times \text{Load impedance} \\ &= 1 \text{ mA} \times 2 \text{ pcs.} \times 3 \text{ k}\Omega \\ &= 6 \text{ V} \end{aligned}$$

Example: Load impedance is 3 kΩ.
Leakage current from switch is 1 mA.

(Reed switch)
Because there is no current leakage, the load voltage will not increase when turned OFF. However, depending on the number of switches in the ON state, the indicator lights may sometimes dim or not light because of the dispersion and reduction of the current flowing to the switches.

Reed Switch: Direct Mounting Style

D-A90(V)/D-A93(V)/D-A96(V)

 For details about certified products conforming to international standards, visit us at www.smcworld.com.

Auto Switch Specifications

PLC: Programmable Logic Controller

D-A90/D-A90V (Without indicator light)			
Auto switch part no.	D-A90/D-A90V		
Applicable load	IC circuit, Relay, PLC		
Load voltage	24 V AC/DC or less	48 V AC/DC or less	100 V AC/DC or less
Maximum load current	50 mA	40 mA	20 mA
Contact protection circuit	None		
Internal resistance	1 Ω or less (including lead wire length of 3 m)		
D-A93/D-A93V/D-A96/D-A96V (With indicator light)			
Auto switch part no.	D-A93/D-A93V		D-A96/D-A96V
Applicable load	Relay, PLC		IC circuit
Load voltage	24 VDC	100 VAC	4 to 8 VDC
Load current range and max. load current	Note 3) 5 to 40 mA	5 to 20 mA	20 mA
Contact protection circuit	None		
Internal voltage drop	D-A93 — 2.4 V or less (to 20 mA)/3 V or less (to 40 mA) D-A93V — 2.7 V or less		0.8 V or less
Indicator light	Red LED illuminates when ON		

Grommet

Electrical entry direction: In-line

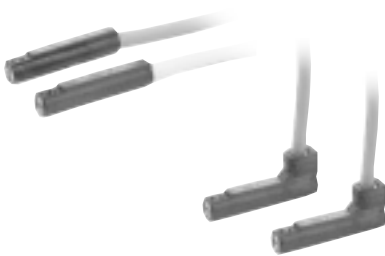

Caution

Operating Precautions

Fix the switch with the existing screw installed on the switch body. The switch may be damaged if a screw other than the one supplied, is used.

Auto Switch Internal Circuit

D-A90(V)

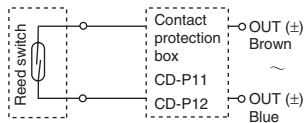

D-A93(V)

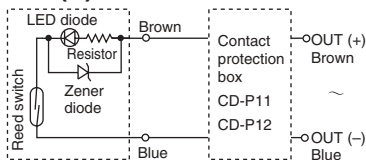

D-A96(V)

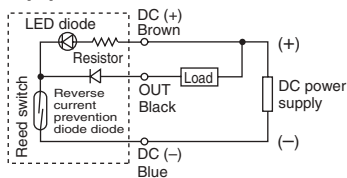

- Note) ① In a case where the operation load is an inductive load.
 ② In a case where the wiring load is greater than 5 m.
 ③ In a case where the load voltage is 100 VAC.

Use the auto switch with a contact protection box in any of the above mentioned cases. (For details about the contact protection box, refer to page 16.)

- Lead wires
 D-A90(V)/D-A93(V) — Oilproof heavy-duty vinyl cable: $\phi 2.7$, 0.18 mm² x 2 cores (Brown, Blue), 0.5 m
 D-A96(V) — Oilproof heavy-duty vinyl cable: $\phi 2.7$, 0.15 mm² x 3 cores (Brown, Black, Blue), 0.5 m
 Note 1) Refer to page 16 for reed switch common specifications.
 Note 2) Refer to page 16 for lead wire lengths.
 Note 3) In less than 5 mA condition, the indicating light visibility becomes low, and it may be unreadable in less than 2.5 mA condition. However, as long as the contact output is over a 1 mA condition, there will be no problem.

Weight

(g)

Auto switch part no.	D-A90	D-A90V	D-A93	D-A93V	D-A96	D-A96V
Lead wire length: 0.5 m	6	6	6	6	8	8
Lead wire length: 3 m	30	30	30	30	41	41

Dimensions

(mm)

D-A90/D-A93/D-A96

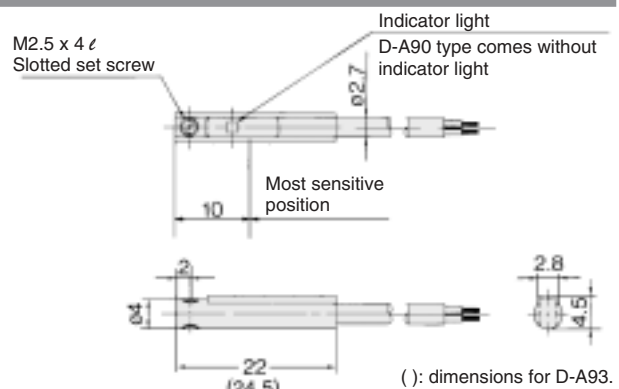

D-A90V/D-A93V/D-A96V

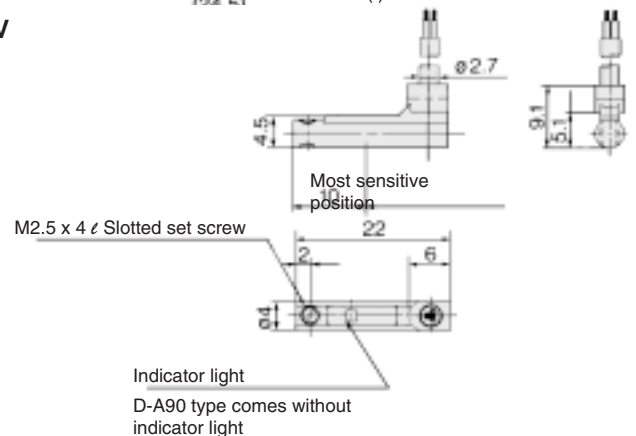

Solid State Switch: Direct Mounting Style

D-M9N(V)/D-M9P(V)/D-M9B(V) C €



For details about certified products conforming to international standards, visit us at www.smcworld.com.

Auto Switch Specifications

PLC: Programmable Logic Controller

D-M9□/D-M9□V (With indicator light)						
Auto switch part no.	D-M9N	D-M9NV	D-M9P	D-M9PV	D-M9B	D-M9BV
Electrical entry direction	In-line	Perpendicular	In-line	Perpendicular	In-line	Perpendicular
Wiring type	3-wire			2-wire		
Output type	NPN		PNP		—	
Applicable load	IC circuit, Relay, PLC				24 VDC relay, PLC	
Power supply voltage	5, 12, 24 VDC (4.5 to 28 V)				—	
Current consumption	10 mA or less				—	
Load voltage	28 VDC or less		—		24 VDC (10 to 28 VDC)	
Load current	40 mA or less				2.5 to 40 mA	
Internal voltage drop	0.8 V or less				4 V or less	
Leakage current	100 μA or less at 24 VDC				0.8 mA or less	
Indicator light	Red LED illuminates when ON.					

Grommet

- 2-wire load current is reduced (2.5 to 40 mA)
- Lead-free
- UL certified (style 2844) lead cable is used.



- Lead wires
 - Oilproof heavy-duty vinyl cable: $\phi 2.7 \times 3.2$ ellipse
 - D-M9B(V) 0.15 mm² x 2 cores
 - D-M9N(V), D-M9P(V) 0.15 mm² x 3 cores

Note 1) Refer to page 16 for solid state switch common specifications.

Note 2) Refer to page 16 for lead wire lengths.

⚠ Caution

Operating Precautions

Fix the switch with the existing screw installed on the switch body. The switch may be damaged if a screw other than the one supplied, is used.

Weight

(g)

Auto switch part no.	D-M9N(V)	D-M9P(V)	D-M9B(V)	
Lead wire length (m)	0.5	8	8	7
	3	41	41	38
	5	68	68	63

Auto Switch Internal Circuit

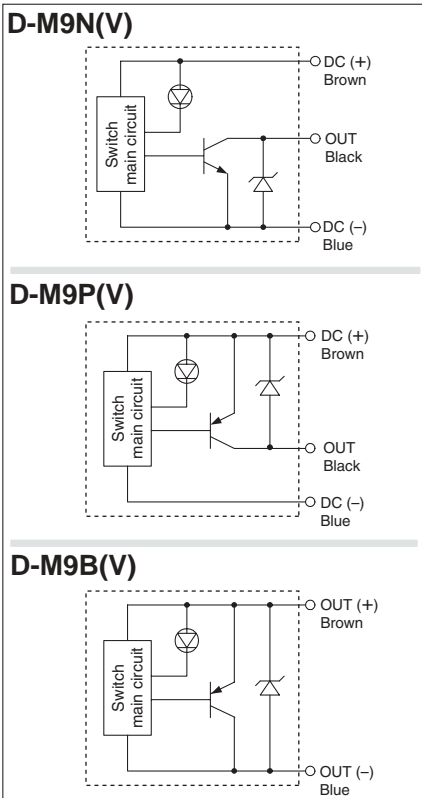

Dimensions

(mm)

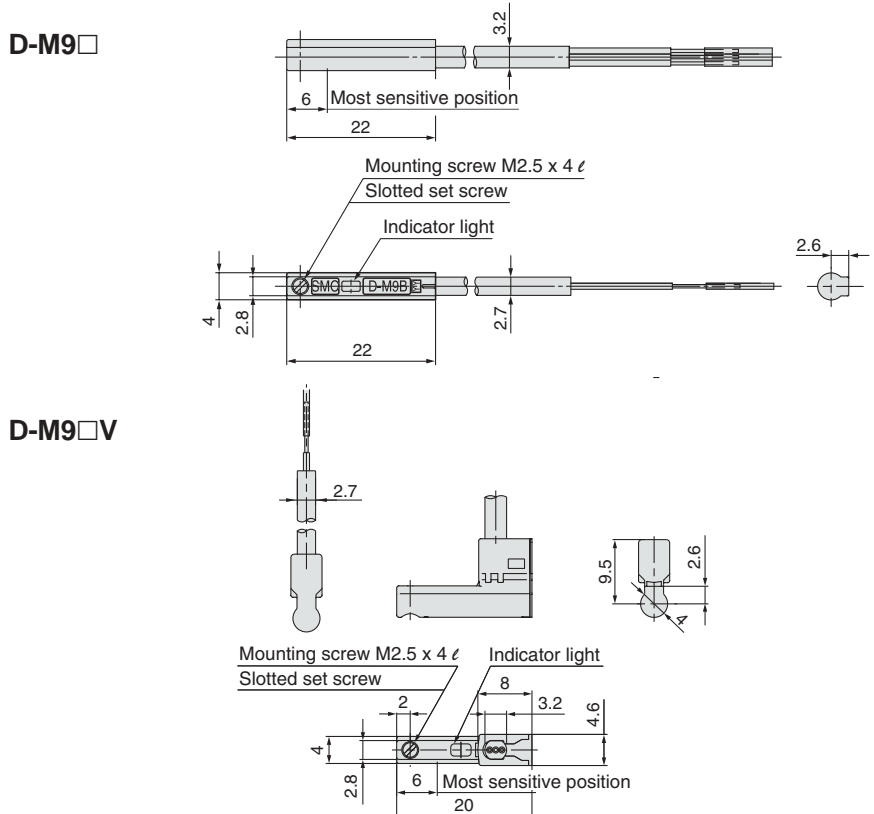

Solid State Switch: Direct Mounting Style

D-F8N/D-F8P/D-F8B



For details about certified products conforming to international standards, visit us at www.smcworld.com.

Auto Switch Specifications

PLC: Programmable Logic Controller

Auto switch part no.	D-F8N	D-F8P	D-F8B
Electrical entry direction	Perpendicular	Perpendicular	Perpendicular
Wiring type	3-wire		2-wire
Output type	NPN	PNP	—
Applicable load	IC circuit, 24 VDC relay, PLC		24 VDC relay, PLC
Power supply voltage	5, 12, 24 VDC (4.5 to 28 V)		—
Current consumption	10mA or less		—
Load voltage	28 VDC or less	—	24 VDC (10 to 28 VDC)
Load current	40 mA or less	80 mA or less	2.5 to 40 mA
Internal voltage drop	1.5 V or less (0.8 V or less at 10 mA load current)	0.8 V or less	4 V or less
Leakage current	100 μ A or less at 24 VDC		0.8 mA or less at 24 VDC
Indicator light	Red LED illuminates when ON.		

Grommet



Caution

Operating Precautions

Fix the switch with the existing screw installed on the switch body. The switch may be damaged if a screw other than the one supplied, is used.

Lead wires

Oilproof heavy-duty vinyl cable: ϕ 2.7, 0.5 m

D-F8N, D-F8P 0.15 mm² x 3 cores (Brown, Black, Blue)

D-F8B 0.18 mm² x 2 cores (Brown, Blue)

Note 1) Refer to page 16 for solid state switch common specifications.

Note 2) Refer to page 16 for lead wire lengths.

Auto Switch Internal Circuit

D-F8N

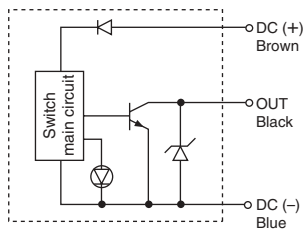

D-F8P

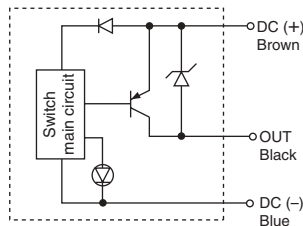

D-F8B

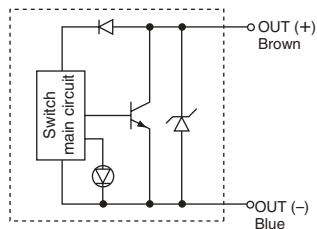

Weight

(g)

Auto switch part no.	D-F8N	D-F8P	D-F8B
Lead wire length (m)	0.5	7	7
	3	32	32
	5	52	52

Dimensions

(mm)

D-F8N/D-F8P/D-F8B

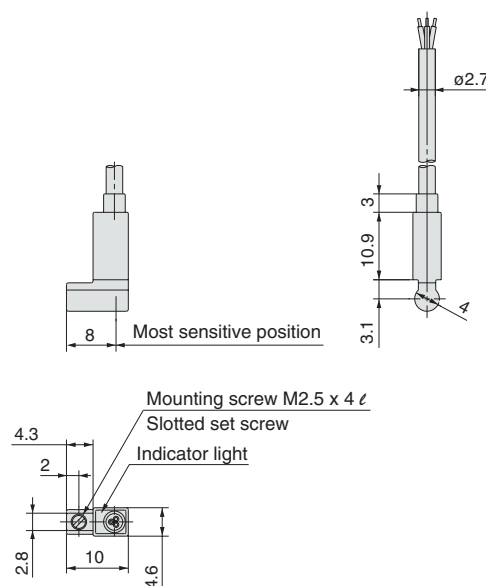

2-color Indication Solid State Switch: Direct Mounting Style D-F9NW(V)/D-F9PW(V)/D-F9BW(V)

For details about certified products conforming to international standards, visit us at www.smcworld.com.

Auto Switch Specifications

PLC: Programmable Logic Controller

D-F9□W/D-F9□WV (With indicator light)						
Auto switch part no.	D-F9NW	D-F9NWV	D-F9PW	D-F9PWV	D-F9BW	D-F9BWV
Electrical entry direction	In-line	Perpendicular	In-line	Perpendicular	In-line	Perpendicular
Wiring type	3-wire				2-wire	
Output type	NPN		PNP		—	
Applicable load	IC circuit, Relay IC, PLC				24 VDC relay, PLC	
Power supply voltage	5, 12, 24 VDC (4.5 to 28 VDC)				—	
Current consumption	10 mA or less				—	
Load voltage	28 VDC or less		—		24 VDC (10 to 28 VDC)	
Load current	40 mA or less		80 mA or less		5 to 40 mA	
Internal voltage drop	1.5 V or less (0.8 V or less at 10 mA load current)		0.8 V or less		4 V or less	
Leakage current	100 μA or less at 24 VDC				0.8 mA or less	
Indicator light	Operating position Red LED illuminates. Optimum operating position Green LED illuminates.					

Grommet

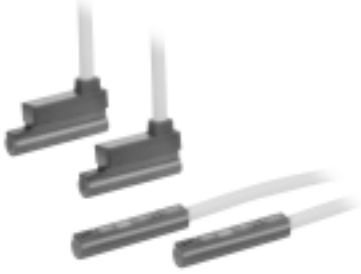

Caution

Operating Precautions

Fix the switch with the existing screw installed on the switch body. The switch may be damaged if a screw other than the one supplied, is used.

Auto Switch Internal Circuit

D-F9NW(V)

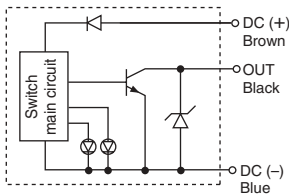

D-F9PW(V)

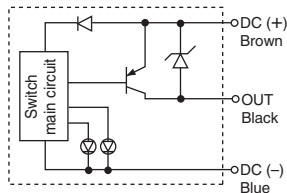

D-F9BW(V)

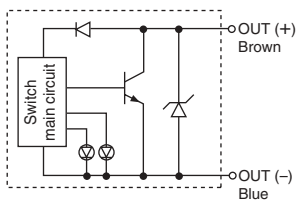

Indicator light/Display method

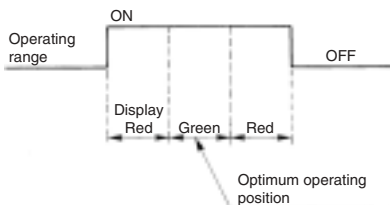

Lead wires

Oilproof heavy-duty vinyl cable: $\phi 2.7$, $0.15 \text{ mm}^2 \times 3$ cores (Brown, Black, Blue), $0.18 \text{ mm}^2 \times 2$ cores (Brown, Blue), 0.5 m

Note 1) Refer to page 16 for solid state switch common specifications.

Note 2) Refer to page 16 for lead wire lengths.

Weight

(g)

Auto switch part no.	D-F9NW(V)	D-F9PW(V)	D-F9BW(V)
Lead wire length (m)	0.5	7	7
	3	34	32
	5	56	52

Dimensions

(mm)

D-F9□W

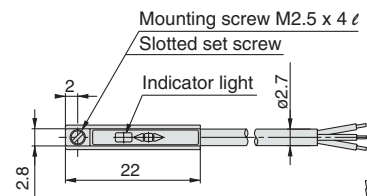
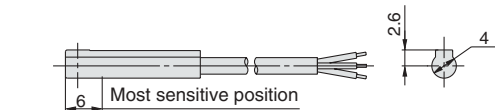

D-F9□WV

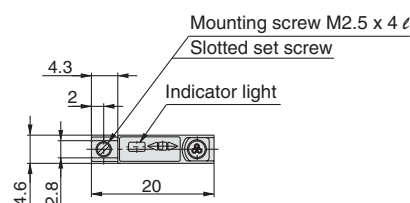
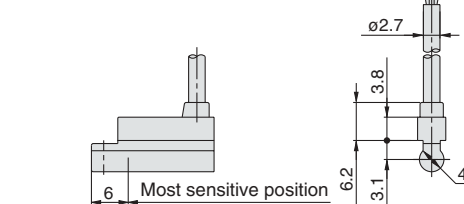



Series *MXJ*

Safety Instructions

These safety instructions are intended to prevent a hazardous situation and/or equipment damage. These instructions indicate the level of potential hazard by labels of "Caution", "Warning" or "Danger". To ensure safety, be sure to observe ISO 4414 ^{Note 1)}, JIS B 8370 ^{Note 2)} and other safety practices.

■ Explanation of the labels

Labels	Explanation of the labels
Danger	In extreme conditions, there is a possible result of serious injury or loss of life.
Warning	Operator error could result in serious injury or loss of life.
Caution	Operator error could result in injury or equipment damage.

Note 1) ISO 4414: Pneumatic fluid power – General rules relating to systems

Note 2) JIS B 8370: General Rules for Pneumatic Equipment

Note 3) Injury indicates light wounds, burns and electrical shocks that do not require hospitalisation or hospital visits for long-term medical treatment.

Note 4) Equipment damage refers to extensive damage to the equipment and surrounding devices.

■ Selection/Handling/Applications

1. The compatibility of the pneumatic equipment is the responsibility of the person who designs the pneumatic system or decides its specifications.

Since the products specified here are used in various operating conditions, their compatibility for the specific pneumatic system must be based on specifications or post analysis and/or tests to meet the specific requirements. The expected performance and safety assurance are the responsibility of the person who has determined the compatibility of the system. This person should continuously review the suitability of all items specified, referring to the latest catalogue information with a view to giving due consideration to any possibility of equipment failure when configuring a system.

2. Only trained personnel should operate pneumatically operated machinery and equipment.

Compressed air can be dangerous if handled incorrectly. Assembly, handling or repair of pneumatic systems should be performed by trained and experienced operators.

3. Do not service machinery/equipment or attempt to remove components until safety is confirmed.

1. Inspection and maintenance of machinery/equipment should only be performed once measures to prevent falling or runaway of the driver objects have been confirmed.
2. When equipment is removed, confirm that safety process as mentioned above. Turn off the supply pressure for this equipment and exhaust all residual compressed air in the system.
3. Before machinery/equipment is restarted, take measures to prevent quick extension of a cylinder piston rod, etc.

4. Contact SMC if the product will be used in any of the following conditions:

1. Conditions and environments beyond the given specifications, or if product is used outdoors.
2. Installation on equipment in conjunction with atomic energy, railway, air navigation, vehicles, medical equipment, food and beverages, recreation equipment, emergency stop circuits, clutch and brake circuits in press applications, or safety equipment.
3. An application which has the possibility of having negative effects on people, property, or animals, requiring special safety analysis.
4. If the products are used in an interlock circuit, prepare a double interlock style circuit with a mechanical protection function for the prevention of a breakdown. And, examine the devices periodically if they function normally or not.

■ Exemption from liability

1. SMC, its officers and employees shall be exempted from liability for any loss or damage arising out of earthquakes or fire, action by a third person, accidents, customer error with or without intention, product misuse, and any other damages caused by abnormal operating conditions.
2. SMC, its officers and employees shall be exempted from liability for any direct or indirect loss or damage, including consequential loss or damage, loss of profits, or loss of chance, claims, demands, proceedings, costs, expenses, awards, judgments and any other liability whatsoever including legal costs and expenses, which may be suffered or incurred, whether in tort (including negligence), contract, breach of statutory duty, equity or otherwise.
3. SMC is exempted from liability for any damages caused by operations not contained in the catalogues and/or instruction manuals, and operations outside of the specification range.
4. SMC is exempted from liability for any loss or damage whatsoever caused by malfunctions of its products when combined with other devices or software.



Series MXJ

Specific Product Precautions 1

Be sure to read this before handling. For Safety Instructions, Actuators Precaution, Auto Switches Precautions, refer to "Precautions for Handling Pneumatic Devices" (M-03-E3A)

Selection

⚠ Caution

1. Operate loads within the range of the operating limits.

When the actuator is used outside the operating limits, eccentric loads on the guide will be excessive and this will cause vibration on the guide, in accuracy and shortened life.

2. If intermediate stops by external stopper is done, avoid ejection.

If lurching occurs, damage can result. Intermediate when making a stop with an external stopper to be followed by continued forward movement, first supply pressure to momentarily reverse the table, then retract the intermediate stopper, and finally apply pressure to the opposite port to operate the table again.

3. Do not use it in such a way that excessive external force or impact force could work on it.

This could result in damage.

Mounting

⚠ Caution

1. Do not scratch or dent on the mounting side of body, table and end plate.

The damage will result in a decrease in parallelism, vibration of guide and an increase in moving part resistance.

2. Do not scratch or dent on the forward side of the rail or guide.

This could result in looseness and increased operating resistance, etc.

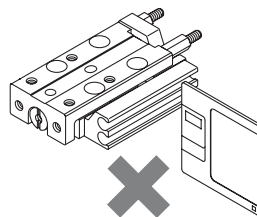
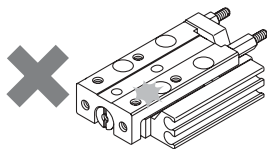

8. Do not attach magnets to the table section.

Since the table is constructed with a magnetic substance, it becomes magnetised when magnets, etc. are attached to it. This may cause malfunction of auto switches, etc.

Mounting

⚠ Caution

3. Do not apply excessive power and load when work is mounted.

If an external force more than the allowable moment is applied, looseness of the guide unit or increased operating resistance could take place.

4. Flatness of mounting surface should be 0.02 mm or less.

Poor parallelism of the workpiece mounted on the air slide table, the base, and other parts can cause vibration in the guide unit and increased operating resistance, etc.

5. Select the proper connection with the load which has external support and/or guide mechanism on the outside, and align it properly.

6. Avoid contact with the air slide table during operation.

Hands, etc. may get caught in the stroke adjuster. Install a cover as a safety measure if there are instances to be near the slide table during operation.

7. Keep away from objects which are influenced by magnets.

Since an air slide table has magnets built-in, do not allow close contact with magnetic disks, magnetic cards or magnetic tapes. Data may be erased.

9. When mounting the air slide table, use appropriate length of screws and do not exceed the maximum tightening torque.

Tightening with a torque above the limit could cause malfunction. Whereas tightening insufficiently could result in misalignment or looseness.

1. Lateral mounting (Body tapped)

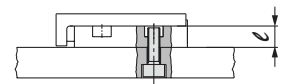

Model	Bolt	Maximum tightening torque (N·m)	Maximum screw-in depth (ℓ mm)
MXJ4	M3	1.14	5
MXJ6	M4	2.7	6
MXJ8	M4	2.7	6

2. Lateral mounting (Through-hole)

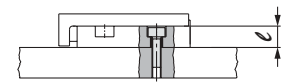

Model	Bolt	Maximum tightening torque (N·m)	ℓ mm
MXJ4	M2.5	0.65	2.5
MXJ6	M3	1.14	3.5
MXJ8	M3	1.14	4

10. Use the speed controllers and fittings shown below.

If other speed controllers and fittings are used, they can interfere with the mounting surface.

Model	Side piping port	Axial piping port	Vacuum port
MXJ4	AS1200-M3	AS1200-M3	Miniature fittings M3 series
MXJ6	AS1200-M3	AS1201F-M3	
MXJ8	AS1201F-M3 AS1301F-M3	AS1301F-M3	

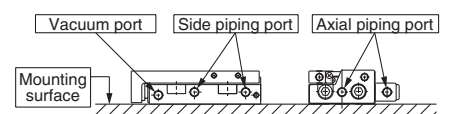



Series MXJ

Specific Product Precautions 2

Be sure to read this before handling. For Safety Instructions, Actuators Precaution, Auto Switches Precautions, refer to "Precautions for Handling Pneumatic Devices" (M-03-E3A)

Mounting

⚠ Caution

1. Front mounting

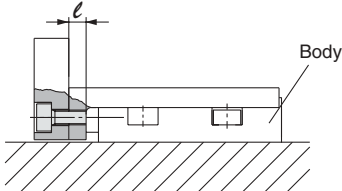

⚠ Caution To prevent the workpiece holding bolts from touching the guide block, use bolts that are at least shorter than the maximum screw-in depth. If longer bolts are used, they can touch the guide and cause a malfunction.

Model	Bolt	Maximum tightening torque (N·m)	Maximum screw-in depth (ℓ mm)
MXJ4	M3	1.14	3.5
MXJ6	M3	1.14	3.5
MXJ8	M3	1.14	3.5

2. Top mounting

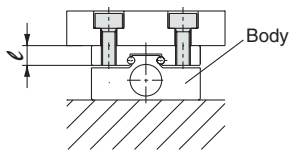

⚠ Caution To prevent the workpiece holding bolts from touching the guide block, use bolts that are at least shorter than the maximum screw-in depth. If longer bolts are used, they can touch the guide and cause a malfunction.

Model	Bolt	Maximum tightening torque (N·m)	Maximum screw-in depth (ℓ mm)
MXJ4	M3	1.14	4
MXJ6	M3	1.14	4
MXJ8	M3	1.14	5.5

1. Use a stepped positioning pin that is provided optionally because the positioning pin hole for the table is a through-hole.

Operating Environment

⚠ Caution

1. Do not use in an environment, where the product could be exposed to liquids such as cutting oil, etc.

Using in an environment where the product could be exposed to cutting oil, coolant, oil, etc. could result in looseness, increased operating resistance, air leakage, etc.

2. Do not use in an environment, where the product could be exposed directly to foreign materials such as powder dust, blown dust, cutting chips, spatter, etc.

This could result in looseness, increased operating resistance, air leakage, etc.

Contact us regarding use in this kind of environment.

3. Do not use in direct sunlight.

4. When there are heat sources in the surrounding area, block off them off.

When there are heat sources in the surrounding area, radiated heat may cause the product's temperature to rise and exceed the operating temperature range. Block off the heat with a cover, etc.

5. Do not subject it to excessive vibration and/or impact.

Contact us regarding use in this kind of environment, since this can cause damage or a malfunction.

6. Be careful about the corrosion resistance of the linear guide.

Be careful as the rail and guide block use martensitic stainless steel, which is inferior to austenitic stainless steel in terms of corrosion resistance. Rust may result especially in an environment that allows water drops from condensation to stay on the surface.

Caution on Adjuster Option

Stroke Adjuster

⚠ Caution

1. Refer to the below table for lock nut tightening torque.

Insufficient torque will cause a decrease in the positioning accuracy.

Model	Thread size	Tightening torque (N·m)
MXJ4	M2.5	0.36
MXJ6	M2.5	0.36
MXJ8	M3	0.63

2. When stroke adjuster is adjusted, do not hit the table with a wrench, etc.

This could result in looseness.



Series MXJ

Specific Product Precautions 3

Be sure to read this before handling. For Safety Instructions, Actuators Precaution, Auto Switches Precautions, refer to "Precautions for Handling Pneumatic Devices" (M-03-E3A)

Caution on replacing standard type to symmetric type, and vice versa

⚠ Caution

Switch rail, axial piping plate and port location can be changed symmetrically. In the event of replacing them, secure with the tightening torque below.

Thread	Thread size	Tightening torque N·m
Cross-recessed head machine screw	M1.7 x 0.35	0.1
Stud	M3	0.3
Dedicated plug	M3	0.3
Hexagon socket set screw	M3	0.3

* No need to applying sealant to the dedicated plug, and stud when exchanging.

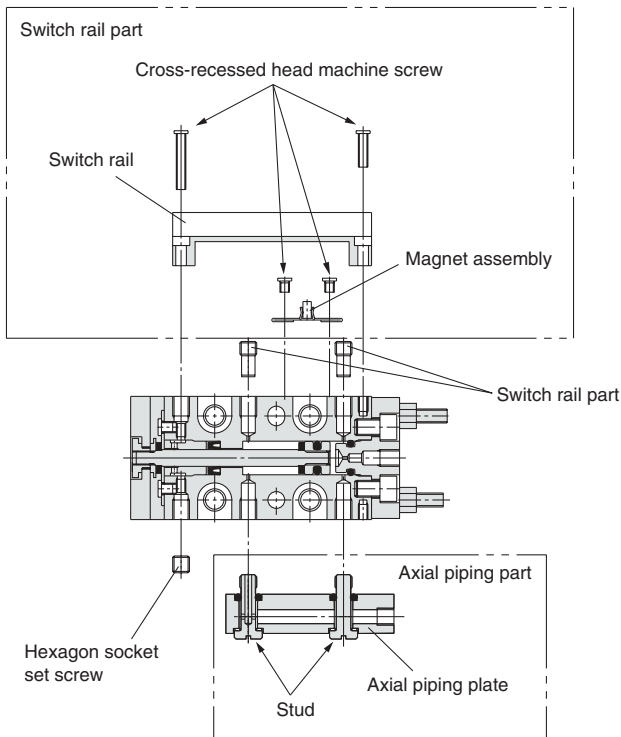

Small product lines



ø2 Miniature fittings
Series M



ø2 One-touch fittings
Series KJ



ø2 Polyurethane tubing
Series TU



Safety Instructions

Be sure to read "Precautions for Handling Pneumatic Devices" (M-03-E3A) before using.

SMC CORPORATION (Europe)

Austria	☎ +43 226262280	www.smc.at	office@smc.at	Lithuania	☎ +370 2651602		
Belgium	☎ +32 (0)33551464	www.smc-pneumatics.be	post@smcpneumatics.be	Netherlands	☎ +31 (0)205318888	www.smc-pneumatics.nl	info@smcpneumatics.nl
Bulgaria	☎ +359 2 9744492	www.smc.bg	office@smc.bg	Norway	☎ +47 67129020	www.smc-norge.no	post@smc-norge.no
Croatia	☎ +385 1 377 66 74	www.smceu.com	office@smc.hr	Poland	☎ +48 225485085	www.smc.pl	office@smc.pl
Czech Republic	☎ +42 0541424611	www.smc.cz	office@smc.cz	Portugal	☎ +351 226108922	www.smces.es	postpt@smc.smces.es
Denmark	☎ +45 70252900	www.smc-pneumatik.com	smc@smc-pneumatik.dk	Romania	☎ +40 213205111	www.smcromania.ro	smcromania@smcromania.ro
Estonia	☎ +372 (0)6593540	www.smc-pneumatics.ee	smc@smcpneumatics.ee	Russia	☎ +812 1185445	www.smc-pneumatik.ru	marketing@smc-pneumatik.ru
Finland	☎ +358 207 513513	www.smc.fi	smcfi@smc.fi	Slovakia	☎ +421 244456725	www.smc.sk	office@smc.sk
France	☎ +33 (0)164761000	www.smc-france.fr	contact@smc-france.fr	Slovenia	☎ +386 73885249	www.smc-ind-avtom.si	office@smc-ind-avtom.si
Germany	☎ +49 (0)61034020	www.smc-pneumatik.de	info@smc-pneumatik.de	Spain	☎ +34 945184100	www.smces.es	post@smc.smces.es
Greece	☎ +30 (0)13426076	www.smceu.com	parianos@hol.gr	Sweden	☎ +46 (0)86031200	www.smc.nu	post@smcpneumatics.se
Hungary	☎ +36 13711343	www.smc-automation.hu	office@smc-automation.hu	Switzerland	☎ +41 (0)523963131	www.smc.ch	info@smc.ch
Ireland	☎ +353 (0)14039000	www.smc-pneumatics.ie	sales@smcpneumatics.ie	Turkey	☎ +90 (0)2122211512	www.entek.com.tr	smc-entek@entek.com.tr
Italy	☎ +39 (0)292711	www.smcitalia.it	mailbox@smcitalia.it	UK	☎ +44 (0)8001382930	www.smc-pneumatics.co.uk	sales@smcpneumatics.co.uk
Latvia	☎ +371 (0)7779474	www.smc.lv	info@smclv.lv				

European Marketing Centre ☎ +34 945184100
SMC CORPORATION ☎ +81 0335022740

www.smceu.com
www.smcworld.com

SMC CORPORATION 1-16-4 Shimbashi, Minato-ku, Tokio 105 JAPAN; Phone:03-3502-2740 Fax:03-3508-2480