

Reduced wiring system

Rockwell International Remote I/O Compatible GW Unit



Instruction Manual

EX500-GAB1-X1



SMC Corporation

URL <http://www.smcworld.com>

Thank you for purchasing the SMC reduced wiring system EX500 series.
Please read this instruction manual carefully and understand the contents before use so that you can operate this unit safely and correctly.
Please keep this manual handy for future reference.

OPERATOR

- This instruction manual has been written for those who have knowledge of machines and equipments that use reduced wiring system as well as the sufficient knowledge to assemble, operate, and maintain such devices.
- Before performing assembly, operation and/or maintenance, please read this manual carefully and understand the contents.

Contents

SAFETY	2
Product Summary.....	5
EX500	
Part Names	6
Dimensions	7
Installation	7
Specification.....	8
Wiring	9
Display/Switch setting	17
SI Unit	
Part Names	20
Dimensions	21
Mounting/Wiring	22
Specification.....	23
Display	24
Input Unit Manifold	
Part Names	25
Dimensions	26
Installation	27
Specification.....	28
Wiring	29
Display	30
Option	31
Troubleshooting.....	33
Appendix Table	34

SAFETY

The body of unit and this manual contain the essential information for the protection of users and others from possible injury and property damage and to ensure correct handling.

Please check that you fully understand the definitions of the following messages (symbols) before going on to read the body of this manual, and always follow the instructions.

Please also read the instruction manuals etc. of related machines and equipments and understand the contents before use.

IMPORTANT MESSAGES

Read this manual and follow its instructions. Signal words such as WARNING, CAUTION and NOTE will be followed by important safety information that must be carefully reviewed.

⚠WARNING

Indicates a potentially hazardous situation that could result in death or severe injury if you do not follow instructions.

⚠CAUTION

Indicates a potentially hazardous situation that, if not avoided, may result in minor injury or moderate injury.

NOTE

Gives you helpful information.

⚠WARNING

Do not disassemble, modify (including modification of printed circuit board) or repair.

Otherwise injury or failure can result.

Do not operate beyond specification range.

Otherwise fire, malfunction or damage to the reduced wiring system can result. Confirm the specifications before operation.

Do not operate in atmosphere of flammable/explosive/corrosive gas.

Otherwise fire, explosion or corrosion can result. This reduced wiring system is not explosion-proof type.

For use in interlock circuit:

- **Provide double interlock system by adding different type of protection (such as mechanical protection).**
- **Check that the interlock circuit is working normally.**

Otherwise accident caused by malfunction can result.

⚠WARNING

Before performing maintenance:

- **Turn off power supply.**
- **Stop air supply, exhaust compressed air in piping, and confirm the release to atmosphere.**

Otherwise injury can result.

⚠CAUTION

Conduct proper functional inspection after completing maintenance.

In the case of abnormality such as unit does not work normally, stop the operation. Otherwise safety cannot be assured due to unintended malfunction.

Provide grounding to improve safety and noise resistance of reduced wiring system.

Provide grounding as close to the unit as possible to shorten distance for grounding.

●Handling precautions

Use the following UL-recognized DC power supply to combine with.

1. UL508-compatible limited voltage/current circuit

A circuit using the secondary coil of an insulating transformer that meets following conditions as power source.

- Maximum voltage (at no load): 30Vrms (42.4Vpeak) or below
- Maximum current:
 - (1) 8A or less (including when short-circuited)
 - (2) When limited by the circuit protector (such as fuse) having the following rating.

No-Load Voltage (Vpeak)	Max. Current Rating (A)
0 to 20 [V]	5.0
Above 20 [V] to 30 [V]	100/peak voltage

2. UL1310-compatible Class 2 power supply unit or circuit of max. 30Vrms (42.4Vpeak) or less using a UL1585-compatible Class 2 transformer as power source. (Class 2 circuit)

SAFETY (continued)

Follow the instructions given below when handling your reduced wiring system. Otherwise a damage or failure to cause a malfunction can result.

- Operate the reduced wiring system at the specified voltage.
- Reserve space for maintenance.
- Do not remove any name plate or label.
- Do not drop, hit or apply an excessive shock to the unit.
- Follow the specified tightening torque.
- Do not apply any excessive force to cables by repeated bending, tensioning or placing a heavy object on the cables.
- Connect wires and cables correctly.
- Do not perform any wiring work while the power is on.
- Do not use the reduced wiring system on the same wiring route as the power line or high voltage line.
- Confirm the insulation of wiring.
- Perform the power supply wiring by dividing into two lines — one is for power supply for output and the other is for power supply for input and controlling GW/SI.
- Take sufficient measures against noise such as noise filter when incorporating the reduced wiring system into a machine or equipment.
- Mount a terminal plug or a waterproof cap on each unused M12 connector for input/output (communication connector, communication ports A - D, and power supply for input and controlling GW/SI).
- Take sufficient shielding measures when operating the product in any of the following places.
 - (1) A place where noise due to static electricity etc. is generated
 - (2) A place of high electric field strength
 - (3) A place where exposure to radioactivity is possible
 - (4) A place near power cable
- Do not operate the product in a place where there is a source of surge.
- Use a surge absorbing element built-in type to directly drive the load that generates surge voltage such as solenoid valve.
- Prevent any foreign matter such as remnant of wires from getting inside the product when opening the station number switch protective cover.
- Install the reduced wiring system in a place free from vibration and impact.
- Operate the product in the specified ambient temperature range.
- Do not use in a place to be affected by the radiant heat from a surrounding heat source.
- Set the DIP switch and rotary switch by using a sharp-pointed watchmakers screwdriver etc.
- Perform the maintenance regularly.
- Conduct an appropriate functional inspection after completing the maintenance.
- Do not use chemicals such as benzine and thinner to clean the product.

Product Summary

● System configuration

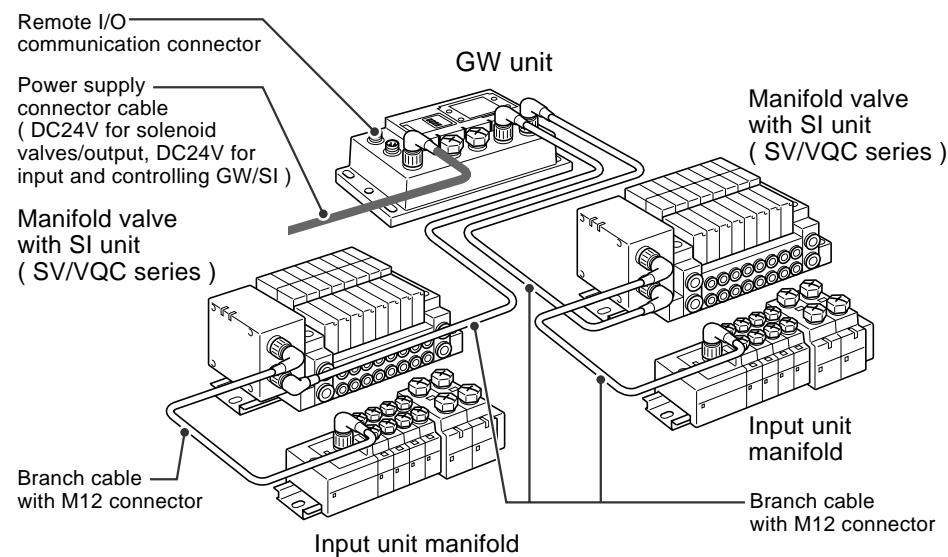

The reduced wiring system is connected to various kinds of fieldbus realizes the reduced wiring and decentralized installation of I/O devices . The signals to/from fieldbus are exchanged by GW unit, and the signals to/from decentralized I/O devices are collected and delivered by GW unit.

The maximum number of connections of manifold valve/Input unit manifold is $16/\text{branch} \times 4 \text{ branches} = 64$ points each for output and input.

As the cables with connectors are used for all wirings among devices, the system complies with the IP65 environment.

EX500 Part Names

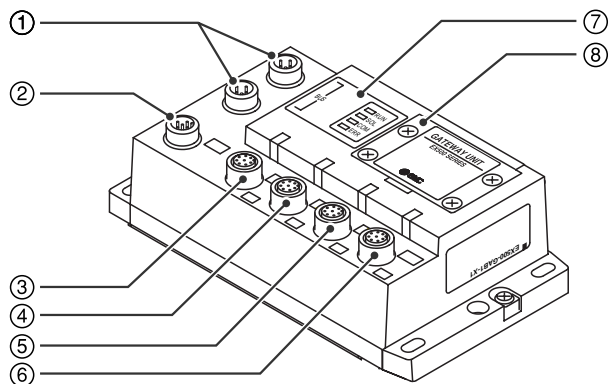

No.	Name	Application
1	Communication connector	Connect with the PLC in which the Remote I/O system made by Rockwell International Corp. is incorporated. (Note 1)
2	Power supply connector	Supply power for output devices such as solenoid valve, for input devices such as sensor, and for controlling GW/SI by using power supply connector cable. (Note1)
3	Communication port A (COM A)	Connect SI unit (manifold valve) or Input unit by using branch cable with M12 connectors. (Note1)
4	Communication port B (COM B)	
5	Communication port C (COM C)	
6	Communication port D (COM D)	
7	Display	Display the power supply status and communication status with PLC. (Note2)
8	Station number switch protective cover	Set the operation by using the switches under this cover. (Note 2)

Note1: For wiring method, refer to subsection "Wiring" (page 9) of section "EX500" in this manual.

Note2: For display and setting method, refer to subsection "Display/Switch Setting" (page 17) of section "EX500" in this manual.

Dimensions (unit: mm)

●EX500 body

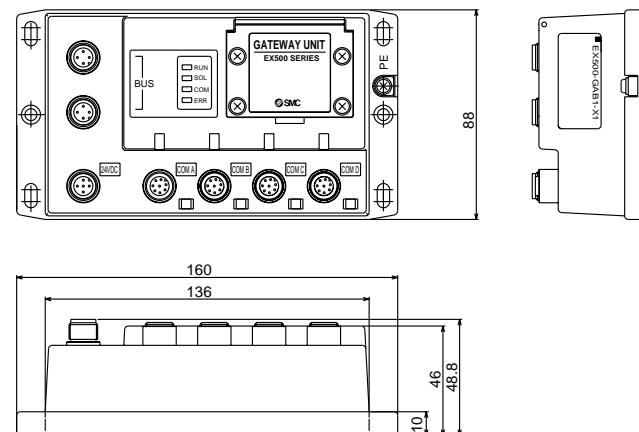

Installation (unit: mm)

●Thread mounting

Secure at four positions with screws with head diameter of 5.2 or more and thread length of 15mm or more.

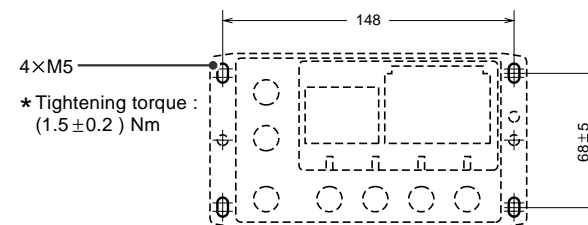

Cutout Dimensions for Mounting (Tolerance: 0.2)

Specification

●Basic specifications

Rated voltage	DC24V
Range of power supply voltage	Power supply for input and controlling GW/SI: DC24V ± 10% Power supply for output: DC24V+10%/-5% (Voltage drop warning at around 20V)
Rated current	Power supply for input and controlling GW/SI: 3.0A (Inside GW unit: 0.2A Input device and SI control section: 2.8A) Power supply for solenoid valves and output: 3A
Number of input/output points	Input point: max. 64/Output point: max 64

●Higher-level bus

Applicable PLC	PLC made by Rockwell International Corp.		
Communication rate	57.6kbps	115.2kbps	230.4kbps
Distance (termination resistor)	3048m[10000feet] (150 Ω)	1524m[5000feet] (150 Ω)	762m[2500feet] (82 Ω)

●Lower-level bus

Number of branches for input/output	4 branches (16 points/branch) for input 4 branches (16 points/branch) for output
Communication method	Protocol: Dedicated for SMC Speed: 500kbps
Branch current for input (Note)	Max. 0.5 [A] per branch (when SI unit and input devices are connected)
Branch current for output	Max. 0.65 [A] per branch (when SI unit EX500-S□01 is connected) Max. 0.75 [A] per branch (when SI unit EX500-Q□01 is connected)
Branch cable length	5m or less per branch (total extended length: 10m or less)

Note: Total value of maximum current consumption and maximum load current of input devices to connect.

Wiring

●Internal circuit

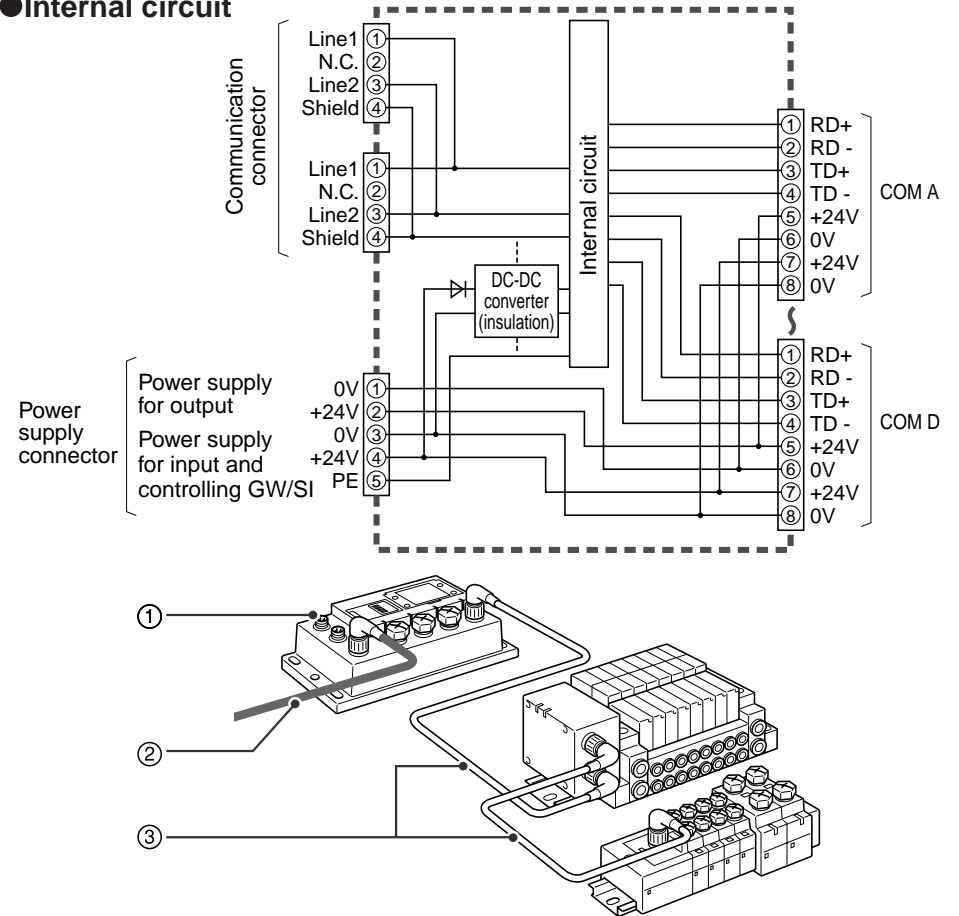

The wirings are described in the following order.

① **Communication wiring: Connection with PLC made by Rockwell International Corp.**

② **Power supply wiring: Connections of power supplies for solenoid valves/output devices, and for input devices and controlling GW/SI**

③ **Branch wiring: Connection from GW unit to SI unit or Input unit**

Wiring (continued)

① Communication wiring

Connect the cable with Remote I/O communication connector to the communication connector of GW unit.

Cable connection

- (1) Aligning the key groove with the communication connector (4-pin, plug) of GW unit, plug the Remote I/O communication cable (socket).
- (2) Tighten the lock nut on cable side by turning it clockwise by hand.
- (3) Confirm that the connector portion does not move.
- (4) Similar to the above, connect the other communication cable (plug) to the other communication connector.
If this EX500 is the end unit of Remote I/O connection, be sure to set the termination resistor.
(For how to set, refer to subsection "Display/Switch Setting" (page 17) of section "EX500" in this manual.)

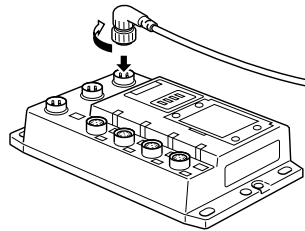
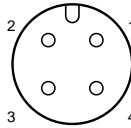

Pin layout and connection diagram of Remote I/O communication connector

Connect the cabled M12 connector (socket) to the communication connector. For the cable to use, refer to "Appendix Table" (page 34) in this manual.

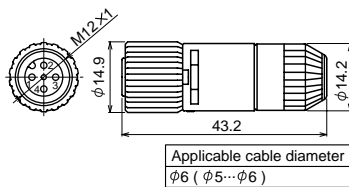

EX500-AC000-AB

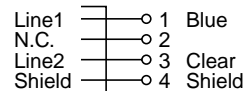

Connection Diagram

Connection of termination resistor

- (1) To the units at both ends of Remote I/O system, be sure to connect "termination resistors". Connect the termination resistor between "Line 1" and "Line 2".
- (2) For Remote I/O system, the termination resistor to connect depends on the communication rate or distance. Refer to the following table.

Communication rate (distance)	Termination resistor
57.6kbps (3048m)	150 Ω 1/2W (brown, green, brown)
115.2kbps (1524m)	
230.4kbps (762m)	82 Ω 1/2W (gray, red, black)

- (3) If this EX500 is the end unit of Remote I/O system, be sure to set the termination resistor. (For how to set, refer to subsection "Display/Switch Setting" (page 17) of section "EX500" in this manual.)

Wiring (continued)

② Power supply wiring

Connect the power supply connector cable to the power supply connector of GW unit. There are two types of cables different in connector shape — straight type and angle type. With this cable, the power is supplied to the output devices such as solenoid valve, and the input devices such as sensor, and for controlling GW/SI. Therefore, there is no need to supply the power to other units individually. When selecting the power supply, refer to "Handling precautions" (page 3) in this manual.

Cable connection

- (1) Aligning the key groove with the power supply connector (plug) of GW unit, plug the power supply cable (socket).
- (2) Tighten the lock nut on cable side by turning it clockwise by hand.
- (3) Confirm that the connector portion does not move.

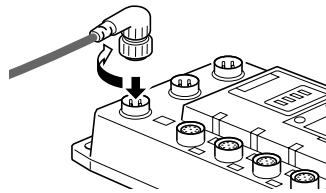

Pin layout and connection diagram of power supply connector cable for (unit: mm)

(Pin layout and connection diagram are common to all cables.)

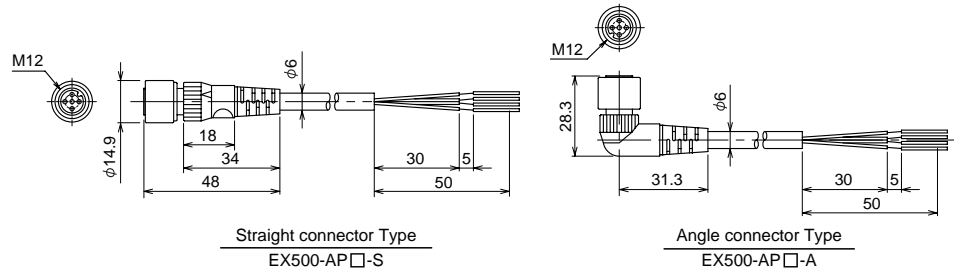

Pin No.	Cable color: Signal name
1	Brown: 0V (for solenoid valves/output)
2	White: DC24V+10%/-5% (for solenoid valves/output)
3	Blue: 0V (for input and controlling GW/SI)
4	Black: DC24V±10% (power supply for input and controlling GW/SI)
5	Gray: Ground (PE)

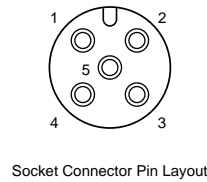

Separate wiring for power supply for solenoid valves/output and for input and control of GW/SI

Both single power supply and two power supply systems can be adopted, however, the wiring shall be made separately (for solenoid valves/output and for input and controlling GW/SI) for either system.

A. Two power supply system

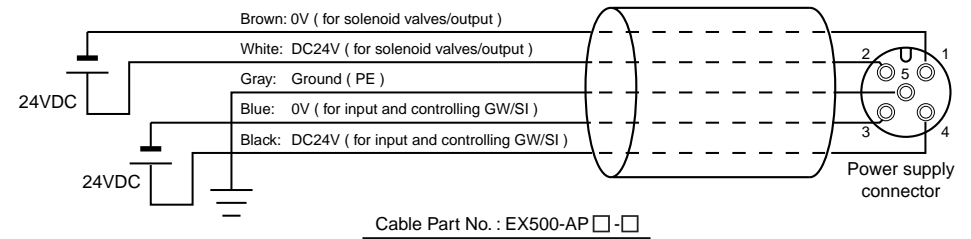

B. Single power supply system

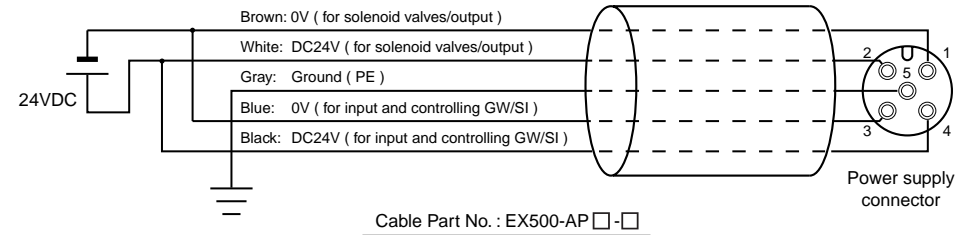

NOTE

Connect a ground cable of 100Ω or less to PE terminal.
(The Shield and PE terminal of Remote I/O are connected inside GW unit through capacitor.)

Wiring (continued)

③ Branch wiring (wiring to communication ports)

For wiring with solenoid valves or input devices, connect the branch cable with M12 connector to communication ports A - D. There are two types of cables different in connector shape — straight type and angle type. As each cable contains power supply wire, there is no need to supply the power to solenoid valves or input devices individually.

Cable connection

- (1) Aligning the key groove with the connector (socket) of GW unit, plug in the cable (plug).

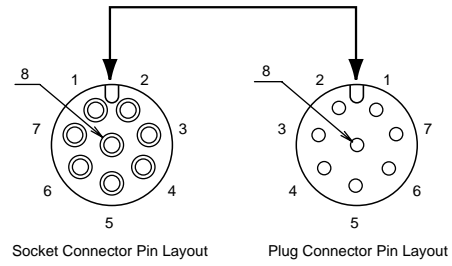

- (2) Tighten the lock nut on cable side by turning it clockwise by hand.
- (3) Confirm that the connector portion does not move.

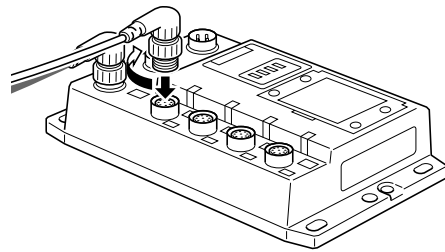

NOTE

Mount a waterproof cap on each unused connector of GW unit. The proper use of waterproof cap can achieve IP65 Enclosure. (Tightening torque: 0.1Nm for M12)

For GW unit – Manifold valve – Input unit manifold configuration

Two communication connectors in SI unit and one communication connector in Input unit are installed respectively. To the communication connector (C2) or (1) of SI unit, connect the branch cable with M12 connector from GW. To the communication connector (C1) or (0), connect the branch cable with M12 connector from Input unit. To the communication connector of Input unit, connect the branch cable with M12 connector from SI unit.

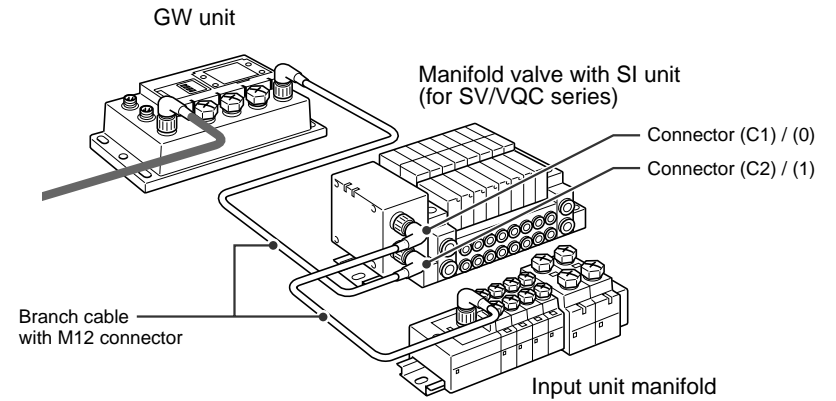

NOTE

When no Input unit is connected to the connector (C1) or (0) of SI unit, mount a terminal plug on the connector.

Manifold valve with SI unit (for SV/VQC series)

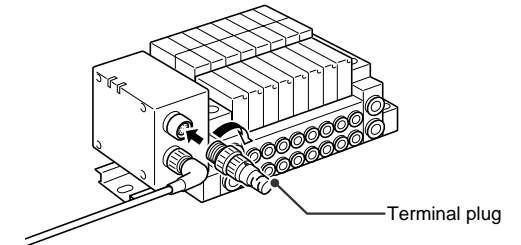

Wiring (continued)

For GW unit – Input unit manifold configuration

To the communication connector of Input unit, connect the branch cable with M12 connector from GW unit.

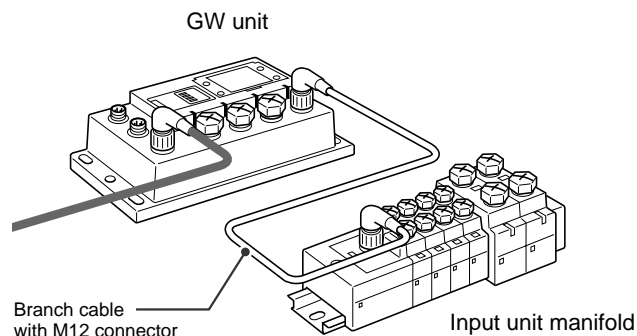

Type, pin layout and connection diagram of the branch cable with M12 connector (EX500-AC □ - □)

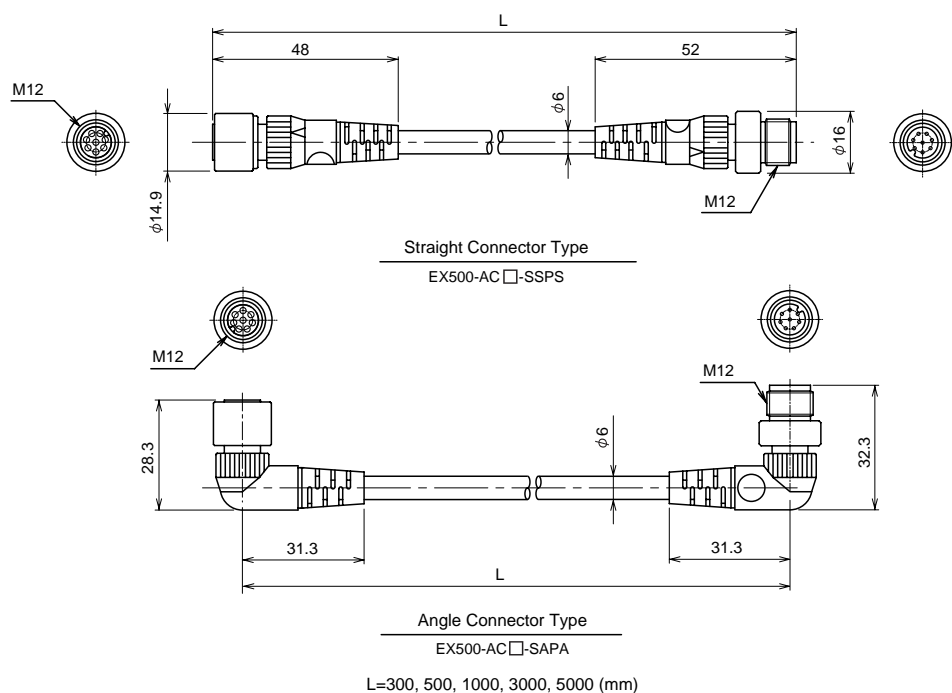

L=300, 500, 1000, 3000, 5000 (mm)

Display/Switch Setting

●Settings for display

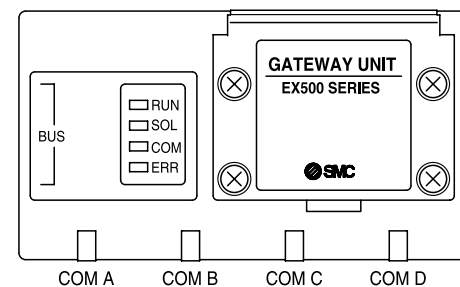

Display	Description
RUN	Lights on: Power for Input and controlling GW/SI is supplied. Lights off: Power for Input and controlling GW/SI is not supplied.
SOL	Lights on: Power is supplied to solenoid valves/output at specified voltage. Lights off: Power is not supplied to solenoid valves/output at specified voltage. (Voltage dropped to lower than 20V.)
COM	Lights on: Remote I/O communication is normal. Lights off: Remote I/O communication is interrupted.
ERR	Lights on: Remote I/O communication is interrupted. Lights off: Remote I/O communication is normal.
COM A	Lights on: COM A is receiving data. Lights off: COM A has no received data.
COM B	Lights on: COM B is receiving data. Lights off: COM B has no received data.
COM C	Lights on: COM C is receiving data. Lights off: COM C has no received data.
COM D	Lights on: COM D is receiving data. Lights off: COM D has no received data.

NOTE

When connecting manifold valve only without connecting Input unit manifold, LEDs of COM A - D do not light. To make them light, connect a terminal plug to the unused connector of SI unit ("C1" or "0").

Display/Switch Setting (continued)

●Switch setting

Open the station number switch protective cover and set the switches with a sharp-pointed watchmakers screwdriver etc.

NOTE

1. Be sure to turn off the power before setting the switches.
2. Be sure to set these switches before use. The factory default settings are all "OFF" or "0".
3. After opening and closing the station number switch protective cover, tighten the screws by proper tightening torque. (Tightening torque: 0.6Nm)

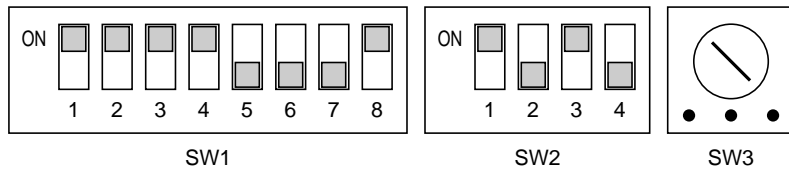

Operation setting switch 1 (SW1)

(1) Rack address (6-bit setting)

The 64 settings from 0 to 74 (octadecimal) are available.

(2) Starting quarter (2-bit setting)

The three settings-First, Second and Third are available.

RACK Address Ex.: 111100 → 74 (octadecimal) Starting Quarter Ex.: 01 → Second

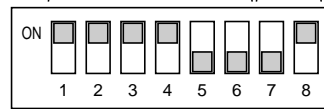

The settings of each switch are as shown in the tables below.

SW1 No.	1	2	3	4	5	6
	32	16	8	4	2	1
Rack Address	0	OFF	OFF	OFF	OFF	OFF
	1	OFF	OFF	OFF	OFF	ON
	2	OFF	OFF	OFF	OFF	ON
	⋮					
	73	ON	ON	ON	OFF	ON
74	ON	ON	ON	ON	OFF	

SW1 No.	7	8	
Starting Quarter	First	OFF	OFF
	Second	OFF	ON
	Third	ON	OFF
	Fourth (Note)	-	-

Note: Unable to set as 1/2 racks are occupied.

Operation setting switch 2 (SW2)

(1) Last rack (1-bit setting)

In the case of last rack, set this switch to ON.

(2) Data rate (2-bit setting)

This switch can set the communication rate.

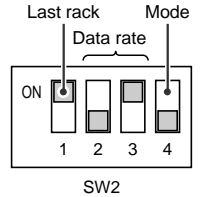

SW2 No.		1	2	3	4
Last rack	No	OFF			
	Yes	ON			
Data rate	57.6kbps	OFF		OFF	
	115.2kbps	OFF		ON	
	230.4kbps	ON	-		
Mode	Clear				OFF
	Hold				ON

(3) Mode (1-bit setting)

This switch can set the operation when communication error occurs.

Setting	Operation
OFF (Clear)	Clears the output status and gets into the suspended status when communication error occurred in Remote I/O. When the signal returned to normal, resets automatically and restarts normal operation.
ON (Hold)	Holds the last normal signal of output status and gets into the suspended status when communication error occurred in Remote I/O. When the signal returned to normal, resets automatically and restarts normal operation.

Operation setting switch 4 (SW4)

This switch can set the termination resistor.

Data rate	Termination resistor
57.6kbps	150 Ω
115.2kbps	150 Ω
230.4kbps	82 Ω

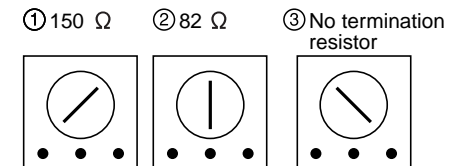

Status of SW3

SI Unit Part Names

The SI unit is the unit to communicate with GW unit in combination with manifold valve. It can be used with SV series valves and VQC series valves.

1. SI unit for SV series valves (EX500-S□01-X1)

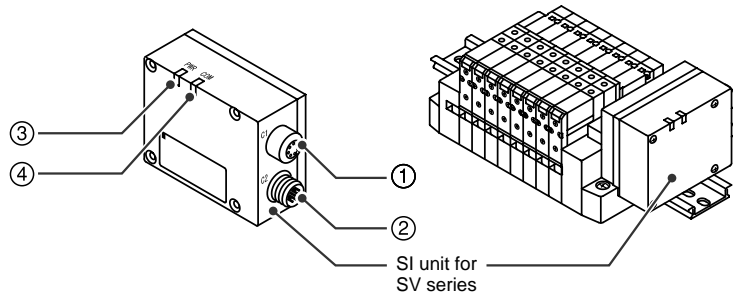

2. SI unit for VQC series valves (EX500-Q□01-X1)

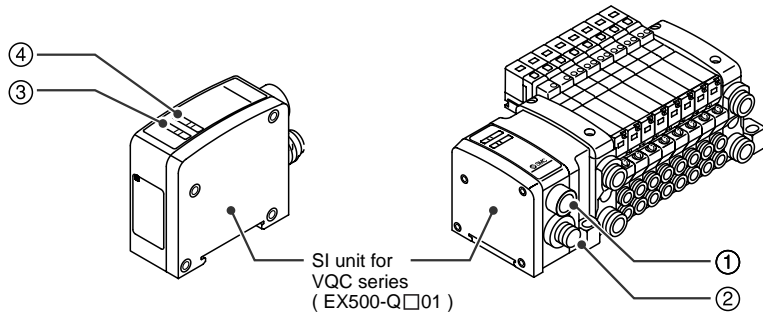

Common to EX500-S□01-X1/EX500-Q□01-X1

No.	Name	Application
1	Communication connector "C1" or "0"	Connects the branch cable to Input unit (branch cable with M12 connector). (Note1)
2	Communication connector "C2" or "1"	Connects the branch cable from GW unit (branch cable with M12 connector). (Note1)
3	Power LED	Indicates the power supply status. (Note2)
4	Communication LED	Indicates the communication status with GW unit: (Note2)

Note1: For wiring method, refer to subsection "Wiring" (page 9) of section "EX500" in this manual.

Note2: For display, refer to "Display" (page 24) in section "SI Unit" in this manual.

Dimensions (unit: mm)

1. SI unit for SV series valves (EX500-S□01-X1)

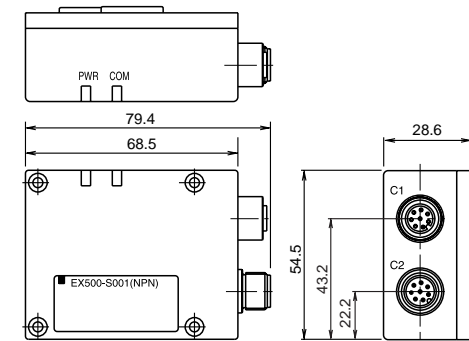

2. SI unit for VQC series valves (EX500-Q□01-X1)

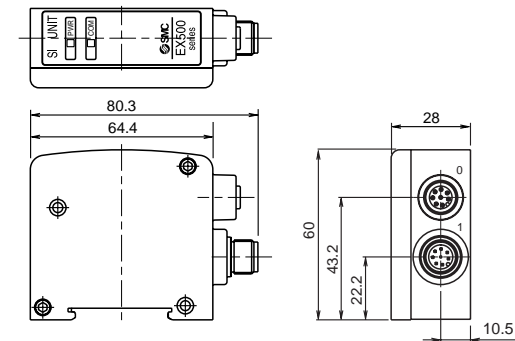

Mounting/Wiring

The mounting and removing methods of SI unit are as shown below.

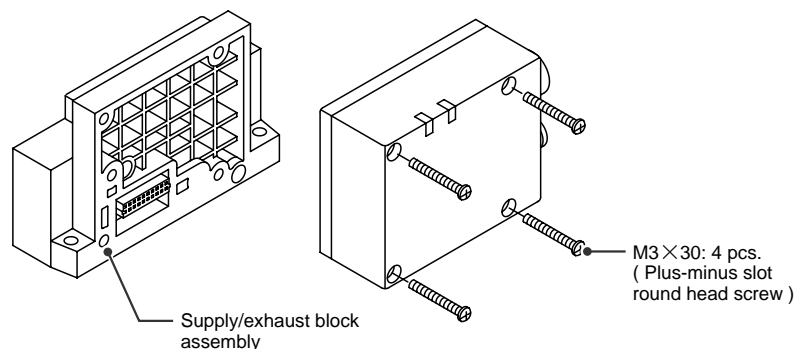

SI Unit for SV Series Valves (EX500-S □ 01-X1)

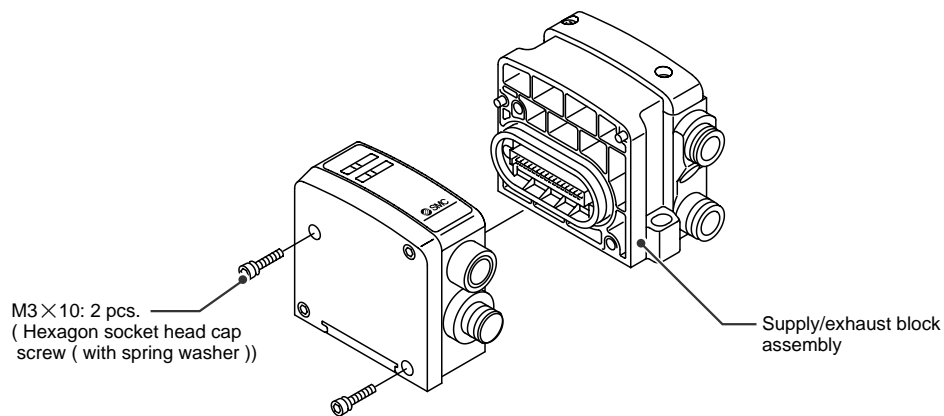

SI Unit for VQC Series Valves (EX500-Q □ 01-X1)

NOTE

Holding with hand so that there will be no gap between SI unit and Air supply/exhaust block assembly, tighten the bolts. Be sure to tighten each bolt by specified tightening torque. (Tightening torque: 0.6Nm)

Note 1 For branch wiring method, refer to subsection "Wiring" (page 9) of section "EX500" in this manual. As the power to output devices such as solenoid valve is supplied by branch wiring (branch cable with M12 connector), there is no need to supply power individually.

Note 2 For mounting/installation methods of solenoid valve, manifold, etc., refer to the catalogs, instruction manuals, technical data, etc. of each valve series.

Specification

1. SI unit for SV series valve (EX500-S □ 01-X1)

Item	Specification	
Connected block	Solenoid valve (single, double) Relay output module (1-point output, 2- point output)	
Connected block station	Double solenoid valve Relay output module (2-point output)	Max. 8 stations
	Single solenoid valve Relay output module (1-point output)	Max. 16 stations
Supply voltage for block	DC24V	
Supply current for block	0.65A Max.	
Current consumption	100mA or less (at rated voltage)	

2. SI unit for VQC series valve (EX500-Q □ 01-X1)

Item	Specification	
Connected block	Solenoid valve (single, double)	
Connected block station	Double solenoid valve	Max. 8 stations
	Single solenoid valve	Max. 16 stations
Supply voltage for block	DC24V	
Supply current for block	0.75A Max.	
Current consumption	100mA or less (at rated voltage)	

3. Applicable valve series

Series	Manifold		Inner diameter of applicable cylinder tube (mm)					
	Cassette	Tie-rod	40	50	63	80	100	125
SV1000	○	○	■					
SV2000	○	○	■	■				
SV3000	-	○	■	■	■			
SV4000	-	○	■	■	■	■		
VQC1000	-	○	■					
VQC2000	-	○	■	■				
VQC4000	-	○	■	■	■	■		

For detailed specifications of solenoid valve and manifold, refer to the catalogs, instruction manuals, technical data, etc. of each valve series.

Display

●SI unit for SV series valves (EX500-S □ 01-X1)

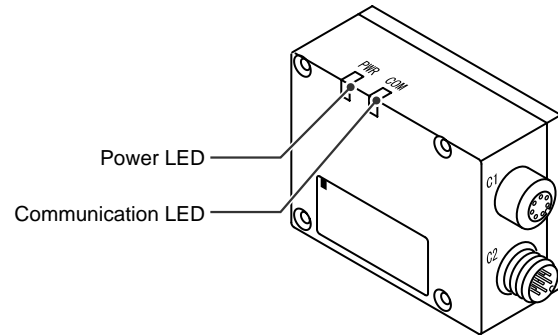

●SI unit for VQC series valves (EX500-Q □ 01-X1)

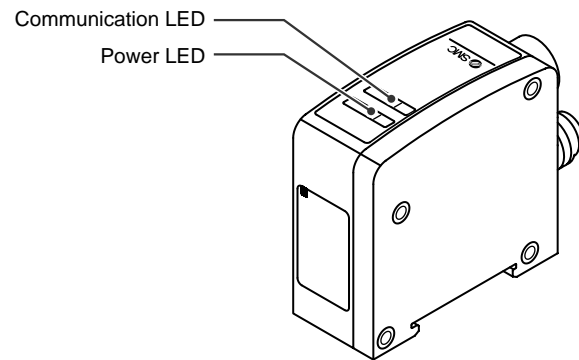

Common to EX500-S □ 01-X1/EX500-Q □ 01-X1

Display	Description
Power LED	Lights on: Power to solenoid valves/output is supplied at the specified voltage. Lights off: Power to solenoid valves/output is not supplied at the specified voltage. (Voltage dropped to lower than 20V.)
Communication LED	Lights on: Receiving data from GW Lights off: No received data

Input Unit Manifold Part Names

The Input unit manifold consists of Input unit, input block (s), end block and DIN rail. The input block up to 8 can be connected (16 points). Any combination of input blocks (for M8 connector, M12 connector and 8-point-integrated type) is acceptable.

Note Do not mix sensor input specifications (PNP and NPN) .

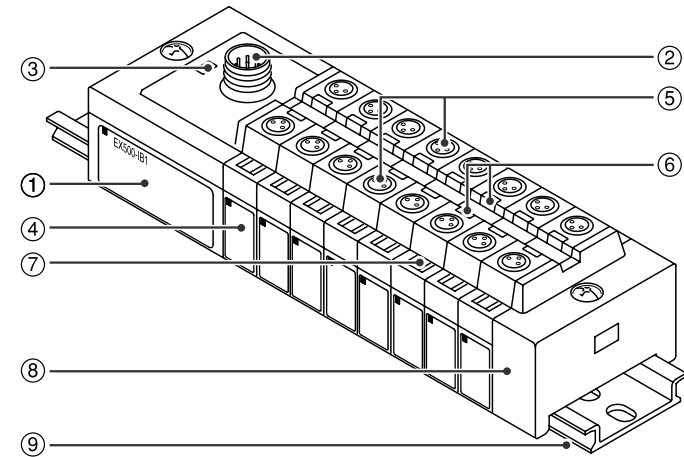

Figure shows the configuration when only input blocks for M8 connector are connected.

No.	Part name	Application
1	Input unit	Unit to communicate with GW unit or SI unit.
2	Communication connector	To be connected with branch cables from GW unit or SI unit (branch cable with M12 connector) (Note1)
3	Power LED	Indicates the power supply status. (Note2)
4	Input block	Unit for sensor signal input.
5	Sensor connector	Connects with sensor. (Note1)
6	Indicator LED	Indicates sensor signal status. (Note2)
7	Marker	To be used for writing input No. etc.
8	End block	Composes the end of Input unit manifold.
9	DIN rail	To be mounted with Input unit manifold.

Note1: For wiring method, refer to subsection "Wiring" (page 29) of section "Input Unit Manifold" in this manual.

Note2: For display, refer to "Display" (page 30) in section "Input Unit Manifold" in this manual.

Dimensions (unit: mm)

●When only input blocks for M8 connector are connected

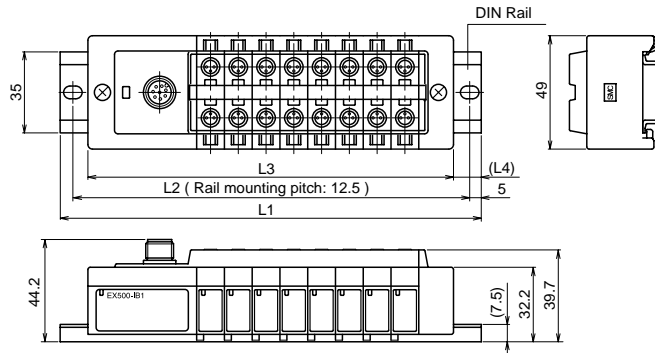

Stations	1	2	3	4	5	6	7	8
L1 [mm]: Rail length	98	110.5	123	135.5	148	160.5	173	185.5
L2 [mm]: Mounting pitch	87.5	100	112.5	125	137.5	150	162.5	175
L3 [mm]: Manifold length	74	86	98	110	122	134	146	158
L4 [mm]	12	12	12.5	12.5	13	13	13.5	13.5

●When only input blocks of 8-point-integrated type are connected

Stations	1	2
L1 [mm]: Rail length	135.5	185.5
L2 [mm]: Mounting pitch	125	175
L3 [mm]: Manifold length	110	158
L4 [mm]	12.5	13.5

●When only input blocks for M12 connector are connected

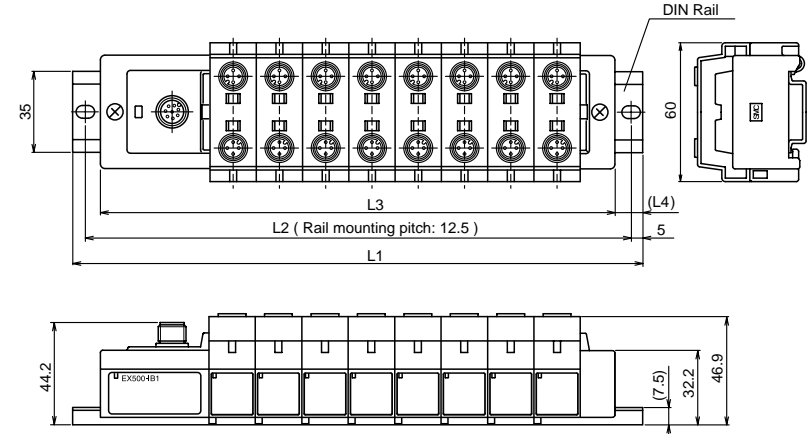

Stations	1	2	3	4	5	6	7	8
L1 [mm]: Rail length	110.5	123	148	173	185.5	210.5	223	248
L2 [mm]: Mounting pitch	100	112.5	137.5	162.5	175	200	212.5	237.5
L3 [mm]: Manifold length	82	102	122	142	162	182	202	222
L4 [mm]	12	12	12.5	12.5	13	13	13.5	13.5

Installation

- ① Connect each connector of Input unit, input blocks, and end block (portion indicated by arrow in the figure to the right).
- ② Holding with hands so that there will be no gap between blocks, place the jointed unit and blocks on DIN rail.
- ③ Tighten the bolts of Input unit and end block to secure the jointed unit and blocks to DIN rail.
Be sure to tighten the bolts by proper tightening torque.
(Tightening torque: 0.6Nm)

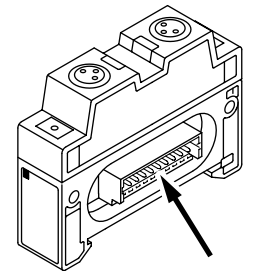

Specification

●Specifications for Input unit

Item	Specification
Connected block	Current source type input block (PNP input block) or Current sink type input block (NPN input block)
Connected block station	Max. 8 blocks
Supply voltage for block	DC24V
Supply current for block	0.65A Max.
Current consumption	100mA or less (at rated voltage)
Short circuit protection	Operates at 1A Typ. (Cuts power supply.) Can be reset by returning the power after cutting the power supply to input and control section of GW unit.

●Specifications for input block

Item	Specification	
	Current source type (PNP output)	Current sink type (NPN output)
Applicable sensor		
No. of input points	2 points/8 points (for M8 connector only)	
Rated voltage	DC24V	
Logical "1" input voltage	15V - 26.4V	0V - 8V
Logical "0" input voltage	0V - 5V	19V - 26.4V
Logical "1" input current	5mA Typ.	-5mA Typ.
Logical "0" input current	1.5mA	-1.5mA
Input delay time	1msec. or less	
Indicator LED	Green LED	
Insulation	N/A	
Supply current to sensor	Max. 480mA/Input unit manifold	

Wiring

●Branch wiring

For wiring method, refer to subsection "Wiring" (page 9) of section "EX500" in this manual. To input devices such as sensor, the power is supplied through the branch wiring (branch cable with M12 connector). Therefore, there is no need to supply the power to them individually.

●Sensor wiring

Connect sensors to the sensor connectors of input block.

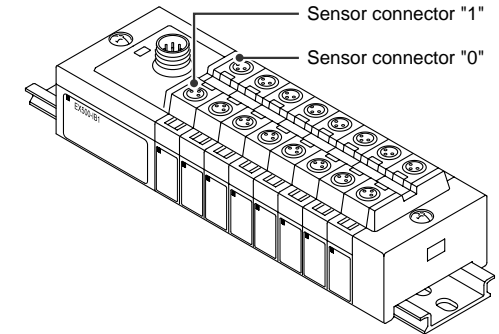

Pin layout of sensor connector

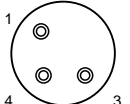
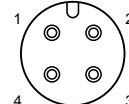
M8 connector (3-pin socket)	M12 connector (4-pin socket)
① Power supply (DC24V) ③ Power supply (0V) ④ Input 	① Power supply (DC24V) ② (Input) (Note) ③ Power supply (0V) ④ Input 

Note: Internal wiring of M12 input block and key position for mounting sensor connector

- No. 2 pins of M12 input block connectors are wired to each other's sensor signal input pins (No. 4 pins) internally.
- This wiring enables direct input of signals from two points combined into one cable through concentric connector etc.
- When connecting sensors, confirm the specification of output signal carefully. Otherwise malfunction can result.
- The key position for mounting sensor connector is as shown to the right. Consider this key position when selecting sensor.

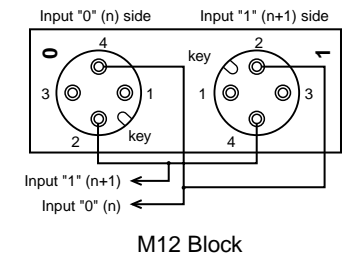

NOTE

Mount a waterproof cap on each unused connector of Input unit. The proper use of waterproof cap can achieve IP65 Enclosure. The waterproof caps are delivered together with each input block as accessories. (Tightening torque: 0.05Nm for M8 and 0.1Nm for M12)

Wiring (continued)

Correspondence between input number and input block

Input block up to 8 can be connected (16 points).
Input numbers are 0 - 15 from Input unit side.

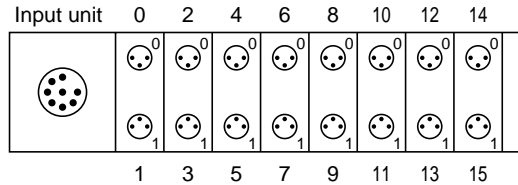

Display

●Settings for display

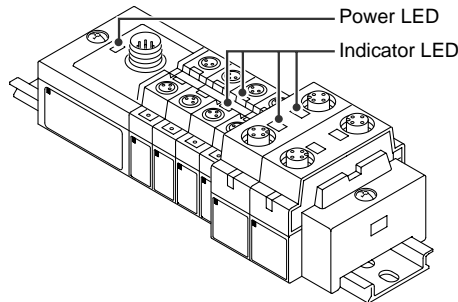

Display	Description
Power LED	Lights on: Power for input and controlling GW is supplied. Blinks: Under short circuit protection (abnormal status). As the short circuit protective function is operating, the power is not supplied. To cancel blinking, turn off and return the power to GW unit. Lights off: Power for input and controlling GW is not supplied.
Indicator LED	Lights on: Sensor signal input ON (logical "1") Lights off: Sensor signal input OFF (logical "0")

Option

- ① Cable with Remote I/O communication connector
For details, refer to subsection "Wiring" (page 9) in section "EX500" in this manual.

How to order

EX500-AC000-AB

Applicable cable diameter
$\phi 6$ ($\phi 5 \cdots \phi 6$)

- ② Branch cable with M12 connector
For details, refer to subsection "Wiring" (page 9) in section "EX500" in this manual.

How to order

EX500-AC030-SSPS

Cable length (L)	Connector specification
003 0.3 [m]	SSPS Socket side: Straight, Plug side: Straight
005 0.5 [m]	SAPA Socket side: Angle, Plug side: Angle
010 1 [m]	
030 3 [m]	
050 5 [m]	

- ③ Power supply connector cable
For details, refer to subsection "Wiring" (page 9) of section "EX500" in this manual.

How to order

EX500-AP050-S

Cable length (L)	Connector specification
010 1 [m]	S Straight
050 5 [m]	A Angle

- ④ Terminal Plug
Connected to C1 (or 0) of SI unit when Input unit manifold is unused. (If this terminal plug is not used, COM LED of GW unit does not light on.)

How to order

EX500-AC000-S

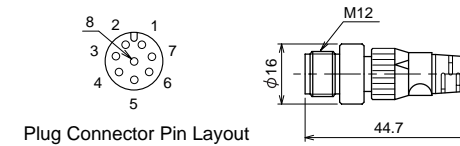

Option (continued)

⑤ Waterproof cap

Mounted on unused ports of GW unit, input block, power block and output block.
The proper use of this waterproof cap can achieve IP65 Enclosure. (The waterproof caps are delivered together with each input block as accessories.)

How to order

EX500-AW

• Connector specification

ES	M8 connector (socket) /10 pcs.
TP	M12 connector (plug) /1 pc.
TS	M12 connector (socket) /10 pcs.



NOTE

Tighten the waterproof cap by the specified tightening torque. (0.05Nm for M8, 0.1Nm for M12)

Troubleshooting

●Overall system

No.	Item	Solution/Corrective action
1	Solenoid valve doesn't work	<ul style="list-style-type: none"> • Check the power for solenoid valves/output (DC24V) is supplied. • Check the connection of the branch cable with M12 connector to SI unit. • Check Power LED and Communication LEDs of SI unit light on.
2	Solenoid valve doesn't work as programmed	<ul style="list-style-type: none"> • Check the wiring specification for manifold block assembly and modify the program.
3	Power LED of Input unit is blinking	<ul style="list-style-type: none"> • Short circuit of input sensor due to failure etc. is possibly caused. Check the sensor. • A current larger than specified value is flowing through the power line for input and controlling GW/SI. Check the power supply section.
4	No signal is input even though connected with sensor(s)	<ul style="list-style-type: none"> • Check the power for input and controlling GW/SI (DC24V) is supplied. • Check indicator LED of each block lights on.
5	COM A - D LED doesn't light on	<ul style="list-style-type: none"> • Check Input unit is connected to the branch of unlit COM port, and the branch cable with M12 connector is connected to the Input unit. • When connecting no Input unit, connect a terminal plug.

Troubleshooting (continued)

●Remote I/O compatible communication

No.	Item	Solution/Corrective action
1	RUN LED is unlit.	<ul style="list-style-type: none"> • Check the power for input and control (DC24V) is supplied.
2	COM LED is unlit. ERR LED is lit.	<ul style="list-style-type: none"> • Check the signal line from PLC is connected correctly. • Check the wiring and pin Nos. • Check the rack address is set correctly. • Check the starting quarter is set correctly. • Check the data rate is set correctly. • Check the last rack is set correctly. • Check the termination resistor setting.
3	SOL LED is unlit.	<ul style="list-style-type: none"> • Check the power for solenoid valves/output (DC24V) is supplied. • Check the power supply voltage for solenoid valves/output doesn't drop under 20V.

Appendix Table

●Cable with Remote I/O communication connector

Manufacturer	Model
Allen-Bradley Company, Inc.	1770-CD
Belden Corporation	9463
Comm Scope Company Network Cable Division General Instrument Corporation	9022

For details or catalog information of communication cable, contact the manufacturer of each cable.