



Energy Saving



■ Gain competitive advantage – discover some simple and effective ways to ensure operational savings and improve productivity

We are all being urged to save energy. Headlines remind us almost daily of the need to reduce our carbon footprint and adopt a greener lifestyle. It's an important issue and one we ignore at our peril. Growing customer expectations and increasing legislation also mean that businesses can no longer afford to ignore green issues.

By adopting an energy saving strategy as a part of your business efficiency programme, not only will you save money but you'll help make a sustainable lifestyle for future generations.

■ How can your business benefit by saving energy?

Higher global energy prices are hitting everyone, and governments, responsible businesses and consumers are all looking at ways to save money, reduce energy consumption and at the same time help the environment.

Whatever business you're in, you have the potential to save energy and money just by making your business more energy efficient.

For example, did you know that the average business wastes around 20% of the energy it uses!

As world leaders in pneumatics, our experts have developed some of the most innovative ranges of energy saving products and activities for compressed air systems which will help you save money as well as helping in the fight to protect our environment.

If this sounds too good to be true, we'll be happy to share our energy efficiency knowledge and technology with you!

We love energy-saving products that save money and help the environment!

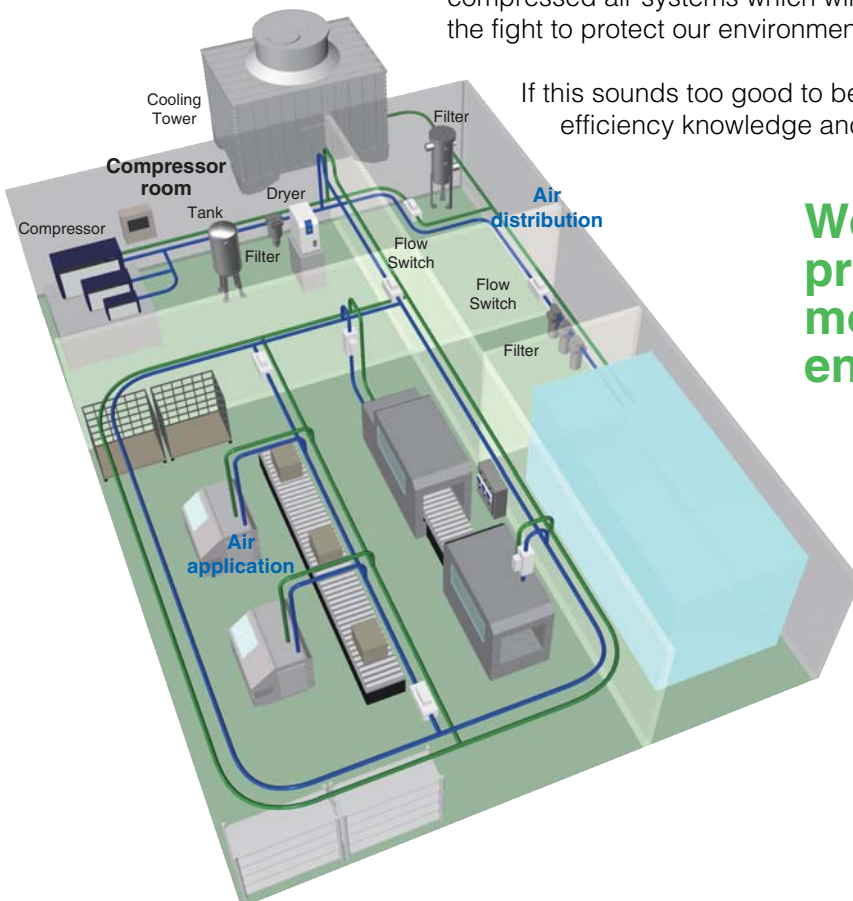

■ How much air do you think is being wasted in compressed air systems used in Europe? _____

According to some recent research there are now more than 320,000 production facilities in Europe using compressed air systems.

In total, the estimated annual industrial electricity consumption in Europe is 400 TWh which is divided into three main energy related categories: Coolant, Compressed Air and Others.

The electrical energy required to manufacture compressed air for these facilities accounts for around 20% of this total industrial consumption.

In an average facility, 70% of the generated compressed air is used in air blow applications, 10% for actuation with the remaining 20% lost through leakage.

Most compressed air users are unaware that their systems often offer poor energy efficiency and that by specifically focusing on these systems savings of between 5 – 50% are the norm.

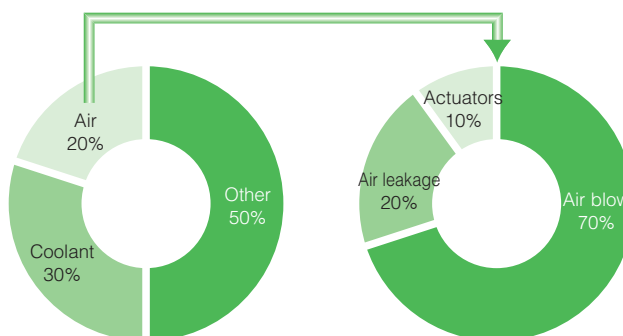

■ Do you know how much money is being wasted? _____

To put this figure into some perspective, if you assume that an average saving of 33% could be achieved thanks to more efficient compressed air systems (26 TWh) and that the average electricity cost is 0.09 €/kWh, the total electrical energy savings in Europe in compressed air systems alone would account for a staggering:

2,340 million euros

And, in addition to these savings we will also stop 10.5 million tons of CO₂ being released into the atmosphere!



So, if you use compressed air in your manufacturing or production facilities, we have energy saving solutions and products to help you reduce your energy consumption thereby saving you money and maximising your energy efficiency.

SMC's Energy Saving Software

■ Energy Saving Software v.3.1b

Every possible calculation related to Energy saving in compressed air Systems, for maximising the efficiency of your system.

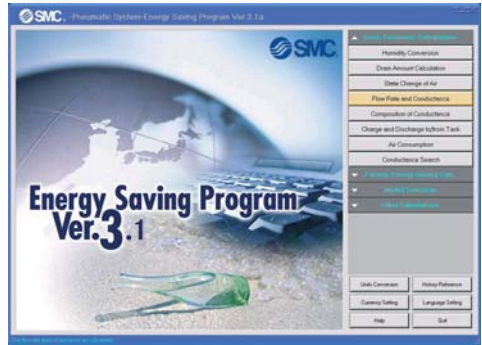

But also in simple applications you can calculate how much money you can save but using our "start" energy saving products.

VMG calculator



VXE calculator



ASR/ASQ calculator



And for correct sizing of your pneumatic circuit, don't forget to use our Model Selection Software.

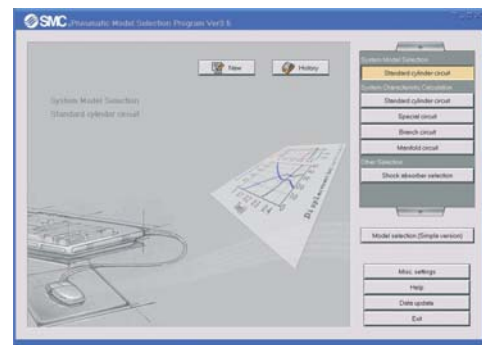

Ten top tips from our compressed air system (CAS) design experts

- Reduce the air pressure to the minimum requirement
- Size the pneumatic components for the actual performance needs
- Filter and dry air in an appropriate way
- Use only quality products
- Isolate the plant when not in use using 2 port valves
- Stop air blow when not needed
- Generate vacuum using multi-stage ejectors with vacuum switches
- Where possible select low energy consuming components
- Periodically check the air consumption
- Prevent and reduce air leaks

SMC Energy Saving Audits

Reason for improvement

Recognise the potential of improvement

Measurement

Recognise current consumption

Improvement

Measurement

Verify the energy consumption after the improvement

Energy savings

As the world leaders in pneumatics, we can provide a specific service for compressed air users aimed at helping achieve maximum energy efficiency.

Throughout Europe our highly trained Energy Saving Teams are on standby to study your complete installation from compressor control to actuator efficiency to detect any leakages and poor performance issues.

This in-depth evaluation includes:

- Inefficient Compressor Control
- Air blow
- Leakages
- Pressure Levels
- Intermittent Demands
- General Air Consumption

Our specialists will monitor your current consumption and evaluate all leakages, using a full range of measuring equipment and checks including:

- Flow, Pressure and Dew Point Monitors/Checks
- Data Loggers
- Filtration and Air Quality Checks
- Ultrasonic Leak Detection
- Infrared Temperature Guns

Once the system has been thoroughly checked from **top- to- bottom**, our Energy Saving experts will provide a comprehensive evaluation of your compressed air system.

This audit includes the following:

- In-depth report of the existing compressed air system
- Measurement and Findings
- Improvement Proposals
- Expected Savings
- Return on Investment Calculations
- System Maintenance Recommendations

And unlike the majority of consultants who will only give you reports and recommendations, our SMC Energy Saving Teams will work with you and your people to help deliver these practical energy saving solutions with guaranteed results of building energy efficiency in your business.

If you're interested in hearing more about our SMC Energy Saving Audits simply check out our dedicated Energy Saving web site on: <http://energysaving.smc.eu>, or contact your local subsidiary for more information.



Index

1 Low Consumption Solenoid Valves

- Energy saving type 2 port solenoid valve **Series VXE**

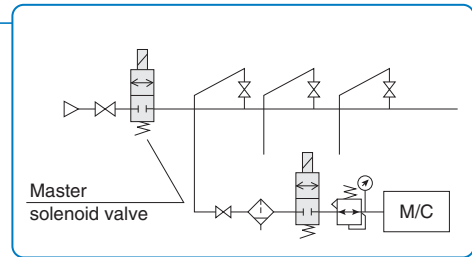

2 Pressure and Flow Monitoring

- Digital flow switch **Series PF2A**
- 2-colour display digital flow switch **Series PFM**
- Differential pressure gauge **GD40-2-01**
- Multi-channel controller for detecting differential pressure **PSE201-X101**

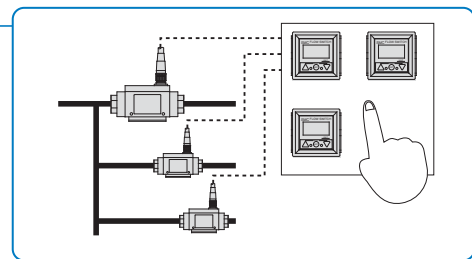

3 Air Blow

- Blow gun **Series VMG**
- Air nozzle **Series KN**

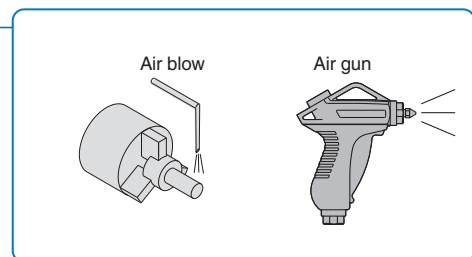

4 Pressure boosters

- Booster regulator **Series VBA**

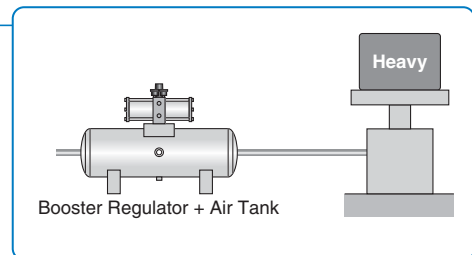

5 Energy Saving Cylinders and Accessories

- Non-rotating double power cylinder **Series MGZ**
- Pressure valve / flow valve **Series ASR / Series ASQ**
- Compact cylinder with solenoid valve **Series CVQ**

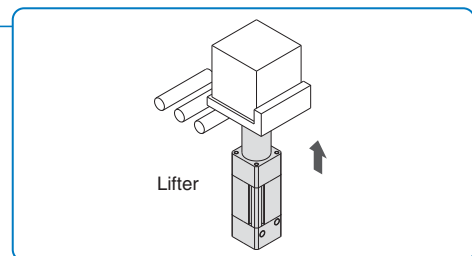

6 Vacuum Equipment

- Multistage ejector **Series ZL**
- Vacuum pad with check valve **INO-3769**
Special order product
- Vacuum ejectors with check valve **Series ZM**
Special order product

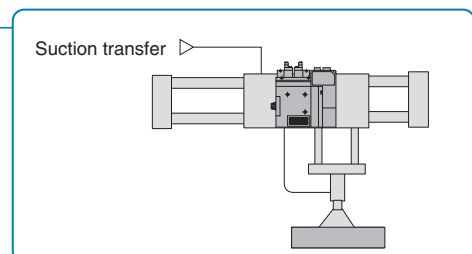

1 Low Consumption Solenoid Valves

Purpose

Reduction of solenoid valves electricity consumption.

For VXE Series power consumption is reduced down to 1/3 with respect to VX Series.

A built-in power-saving circuit (based on the Pulse Width Modulation method) allows same performance with reduced energy consumption.

Before improvement

Voltage is applied to the coil during the whole ON regime of the valve, even during holding.

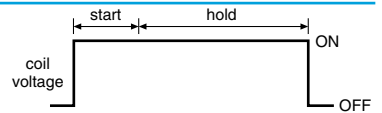

After improvement

The power consumption required to hold the solenoid in the ON position is optimised. Hence, less energy is consumed.

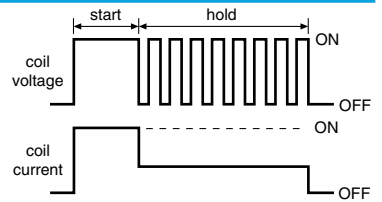

Energy Saving Type 2 Port Solenoid Valve

Series VXE



- Energy saving type of the VX2, VXD2 and VXZ2 2 port solenoid valve series (replaceable coil).
- Coil heat reduction.
- Single and manifold options available.
- For various fluids and variety of sizes.
- Applicable voltages: 24 and 12 V DC.

Part number	Orifice size [mm]	Port size	Rated voltage + Electrical entry
-------------	-------------------	-----------	----------------------------------

Series VXE2 Direct operated type

VXE2110-01F-5DO1	2	G1/8"	24 V DC, for DIN terminal (without connector, with gasket), with built-in surge voltage suppressor circuit
VXE2120-02F-5DO1	3	G1/4"	
VXE2230-02F-5DO1	4.5	G3/8"	
VXE2240-03F-5DO1	6		
VXE2350-03F-5DO1	8	G1/2"	
VXE2360-04F-5DO1	10		

Series VXD2 Pilot operated type

VXD2130-02F-5DO1	10	G1/4"	24 V DC, for DIN terminal (without connector, with gasket), with built-in surge voltage suppressor circuit
VXD2140-03F-5DO1		G3/8"	
VXD2140-04F-5DO1	15	G1/2"	
VXD2150-06F-5DO1	20	G3/4"	
VXD2260-10F-5DO1		25	

Series VXEZ2 Zero differential pressure pilot operated type

VXEZ2230-02F-5DO1	10	G1/4"	24 V DC, for DIN terminal (without connector, with gasket), with built-in surge voltage suppressor circuit
VXEZ2230-03F-5DO1		G3/8"	
VXEZ2240-04F-5DO1	15	G1/2"	
VXEZ2350-06F-5DO1	20	G3/4"	
VXEZ2360-10F-5DO1		25	

5 Port Solenoid Valve

Series VQ/VQC



- Power consumption: Standard: 0.4 W / High Pressure option (1MPa): 0.95 W

5 Port Solenoid Valve

Series SY



- Power consumption: 0.35 W / 0.1 W (with energy saving circuit)

5 Port Solenoid Valve

Cassette Type Series SJ2000/3000



- Power consumption: 0.15 W (with energy saving circuit)

2 Pressure and Flow Monitoring

Purpose

Pressure and flow rate maintenance.

Before improvement

Pressure and flow rate losses due to leaks or clogging of the elements are not controlled.

This causes the compressor, pump, etc. to work harder with subsequent, unnecessary air consumption.

After improvement

The effective use of measuring instruments optimises the installation performance.

Regular maintenance of clogged elements is implemented by mounting (differential) pressure monitoring equipment in every line.

Air leakage is also detected and controlled with flow switches.

Differential Pressure Gauge GD40-2-01

Part number
GD40-2-01

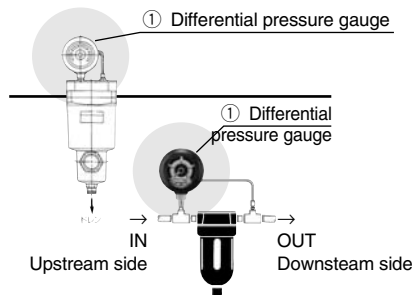

Digital Flow Switch Series PF2A



- For air.
- Simple, LED display readout.
- Either integrated or remote combination of sensor and display.
- Key pad for simple adjustments.
- 2 independent outputs/switch points.
- No mechanically moving parts, so longer service life.



4-channel Flow Monitor
Series PF2D20□

Integrated type

Part number	Flow rate (ℓ/min)	Min. set unit (ℓ/min)	Switch outputs	Supply voltage	Operating pressure range	
PF2A710-F01-67N	1 ~ 10	0.1	2 x PNP 80 mA	12 - 24 VDC	-50 kPa ~ 0.5 MPa	
PF2A710-F02-67N	1 ~ 10					
PF2A750-F01-67N	5 ~ 50	0.5				-50 kPa ~ 0.75 MPa
PF2A750-F02-67N	5 ~ 50					
PF2A711-F03-67N	10 ~ 100	1			0.1 ~ 1.5 MPa	
PF2A721-F03-67N	20 ~ 200	2				
PF2A751-F04-67N	50 ~ 500	5	1 x PNP 80 mA Analogue: 4 ~ 20 mA	24VDC		
PF2A703H-F10-69N	150 ~ 3000	5				
PF2A706H-F14-69N	300 ~ 6000	10				
PF2A712H-F20-69N	600 ~ 12000					

Remote type

Part number	Flow rate (ℓ/min)	Type	Switch outputs	Supply voltage	Operating pressure range	
PF2A510-F01N	1 ~ 10	Measuring sensor	-	12 - 24 VDC	-50 kPa ~ 0.5 MPa	
PF2A510-F02N	1 ~ 10					
PF2A550-F01N	5 ~ 50					-50 kPa ~ 0.75 MPa
PF2A550-F02N	5 ~ 50					
PF2A511-F03N	10 ~ 100				-	
PF2A521-F03N	20 ~ 200					
PF2A551-F04N	50 ~ 500	Display	2 x PNP, 80 mA		-	
PF2A301-A	1 ~ 50					
PF2A311-A	10 ~ 500					

Accessory Cable/plug with ferrite core

Straight	ZS-29-A
----------	---------

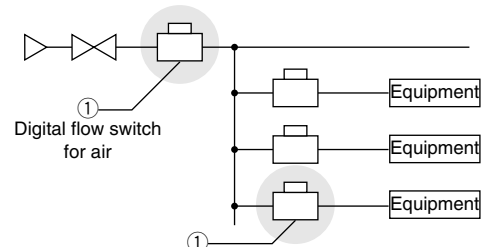

■ 2-Colour Display Digital Flow Switch

Series PFM



- For air, N₂, Ar and CO₂.
- A digital flow switch that uses a MEMS sensor for detecting the flow.
- Compact size.
- Improved visibility with two colour display indication.
- Two piping directions are possible.
- Integrated flow adjustment valve.
- Multiple mounting combinations.

Integrated type

Part number	Flow rate Dry air, N ₂ , Ar	Flow rate CO ₂	Supply voltage	Operating pressure range
PFM710 * - ** - ***	0.2 to 10 ℓ/min	0.2 to 5 ℓ/min	24 V DC	-100 kPa to 750 kPa
PFM725 * - ** - ***	0.5 to 25 ℓ/min	0.5 to 12.5 ℓ/min		
PFM750 * - ** - ***	1 to 50 ℓ/min	1 to 25 ℓ/min		
PFM711 * - ** - ***	2 to 100 ℓ/min	2 to 50 ℓ/min		

Remote type

Part number	Flow rate Dry air, N ₂ , Ar	Flow rate CO ₂	Supply voltage	Operating pressure range
PFM510 * - ** - 2	0.2 to 10 ℓ/min	0.2 to 5 ℓ/min	24 V DC	-100 kPa to 750 kPa
PFM525 * - ** - 2	0.5 to 25 ℓ/min	0.5 to 12.5 ℓ/min		
PFM550 * - ** - 2	1 to 50 ℓ/min	1 to 25 ℓ/min		
PFM511 * - ** - 2	2 to 100 ℓ/min	2 to 50 ℓ/min		

PFM5 - Output specification

2	Analogue output (4 to 20 mA)
---	------------------------------

*	Flow adjustment valve
-	Without flow adjustment valve
S	With flow adjustment valve

*** PFM7 - Output specification

B	2 PNP outputs
E	1 PNP output + Analogue (1 to 5 V)
F	1 PNP output + Analogue (4 to 20 mA)

** Port size (straight piping)

Symbol	Description	Flow rate range			
		10	25	50	11
F01	G1/8"	•	•	•	
F02	G1/4"				•
C4	ø4 one-touch fitting	•			
C6	ø6 one-touch fitting	•	•	•	•
C8	ø8 one-touch fitting		•	•	•

Accessories

ZS-33-D	Lead wire with connector (2 m)
ZS-33-F	Lead wire with connector (2 m) + rubber cover for connector
ZS-33-M	Bracket (for "without adjustment flow valve")
ZS-33-MS	Bracket (for "with adjustment flow valve")
ZS-33-J	Panel mount adapter (for "without adjustment flow valve")
ZS-33-JS	Panel mount adapter (for "with adjustment flow valve")
ZS-33-R*	DIN rail mounting bracket *=number of stations (1 to 5)

Flow sensor monitor

Part number	Input specification	Current input	
		Output specification	
PFM313-LF	Current input	2 PNP + 1 to 5 V outputs	
PFM314-LF		2 PNP + 4 to 20 mA outputs	

Accessories

ZS-28-B	Bracket
ZS-27-C	Panel mount adapter
ZS-27-D	Panel mount adapter + front protective cover
ZS-28-C-1	Sensor connector

■ Multi-Channel Controller for Detecting Differential Pressure

PSE201-X101

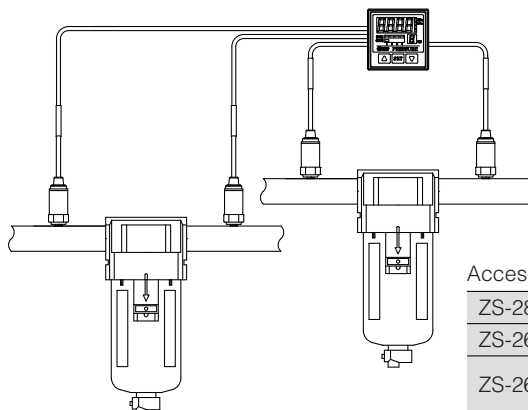

Part number

PSE201-X101

Accessories

ZS-28-C	E-con connector for sensor (1pc)
ZS-26-B	Panel mount adapter
ZS-26-C	Panel mount adapter with front protective cover

3 Air Blowing

Purpose

Reduction of pressure consumption when air blowing.

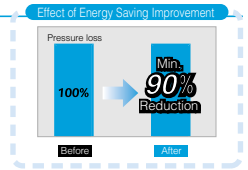

Before improvement

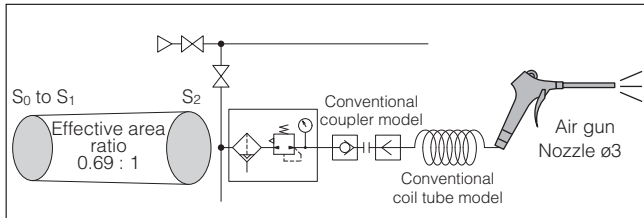

Factory air line pressure is used directly.

After improvement

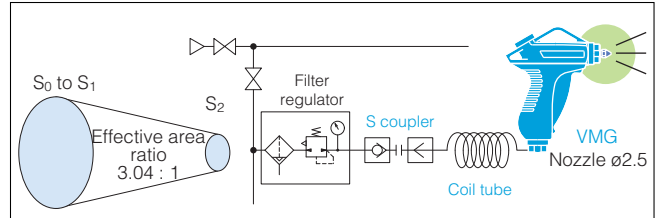

With VMG blow guns, pressure loss is reduced in the air flow direction.

Adding a KN nozzle, the effective area with the upstream side is improved (increased), hence pressure loss is reduced.

		Before improvement	After improvement
Equipment	Coupler	Conventional model	S coupler
	Piping	Conventional coil tube model (I.D. ø5, equivalent length 5 m)	TCU1065-1-20-X6
	Air gun	Conventional model (Nozzle size ø3)	VMG (Nozzle size ø2.5)
Effective area	Coupler, Piping (S ₀)	6.8 mm ²	13.45 mm ²
	Air gun (S ₁)	6 mm ²	30 mm ²
	Nozzle (S ₂)	6.3 mm ²	4.4 mm ²
Effective area ratio (S ₁ to S ₂)		0.69 : 1	3.04 : 1
Impact pressure		0.011 MPa (at a distance of 100 mm)	0.011 MPa (at a distance of 100 mm)
Regulator pressure		0.5 MPa	0.4 MPa
Pressure inside nozzle		0.276 MPa	0.385 MPa
Compressor pressure		0.6 MPa	0.5 MPa
Air consumption		287 dm³/min (ANR)	257 dm³/min (ANR)
Electricity consumed by compressor		1.56 kW	1.25 kW

Blow Gun

Series VMG



- Ergonomically designed body with patented valve design and KN nozzles produces considerably reduction in pressure losses.
- 2 connection options.
- Minimum actuation force required.

Part number	Piping direction	Port thread	Colour	Operating pressure range (MPa)
VMG11BU-F02	Bottom	G1/4"	Blue	0 - 1,0
VMG11BU-F03		G3/8"		
VMG11W-F02		G1/4"	White	
VMG11W-F03		G3/8"		
VMG12BU-F02	Top	G1/4"	Blue	
VMG12BU-F03		G3/8"		
VMG12W-F02		G1/4"	White	
VMG12W-F03		G3/8"		

Air Nozzle

Series KN

Male Thread Nozzle



Part number	Nozzle-Ø (mm)	Piping thread
KN-R02-100	1	R 1/4"
KN-R02-150	1,5	R 1/4"
KN-R02-200	2	R 1/4"
KN-R02-250	2,5	R 1/4"

Low Noise Nozzle



Part number	Nozzle-Ø (mm)	Piping thread
KNS-R02-075-4	ø0.75 x 4	R 1/4"
KNS-R02-090-8	ø0.9 x 8	R 1/4"
KNS-R02-100-4	ø1 x 4	R 1/4"
KNS-R02-110-8	ø1.1 x 8	R 1/4"

Long Copper Pipe Nozzle



Part number	Nozzle-Ø (mm)	O.D. (mm)	Length (mm)
KNL3-06-150	1,5	6	300
KNL3-06-200	2	6	300
KNL6-06-150	1,5	6	300
KNL6-06-200	2	6	300

High Efficiency Nozzle



Part number	Nozzle-Ø (mm)	Piping thread
KNH-R02-100	1	R 1/4"
KNH-R02-150	1,5	R 1/4"
KNH-R02-200	2	R 1/4"

4 Pressure Boosters

Purpose

Increase factory air pressure.

Before improvement

Force is insufficient due to low factory pressure. Increasing factory pressure is not efficient because of compressor energy consumption.

After improvement

Factory air pressure is increased up to twice with no need of an electrical supply.

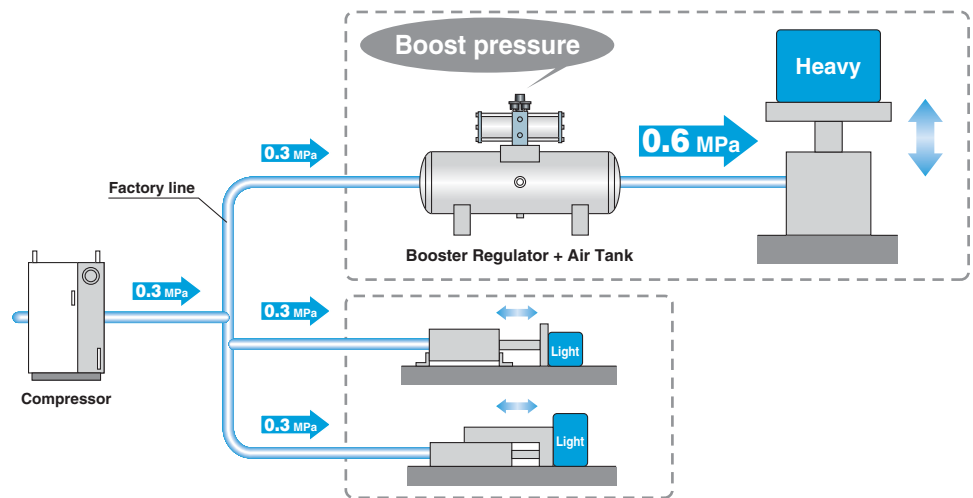

Booster Regulator Series VBA



- Increases the main circuit pressure to an adjustable value.
- Major energy savings.
- No other energy source required.
- Operating temperature: 2-50 C.
- Input pressure: 0.1-1 MPa.
- Mounting position: horizontal.
- Improved service life: Floating piston structure and grease retaining groove.
- Improved reliability: Built-in mesh filter at IN port.
- Reduced noise.

Part number	Operating range (MPa)	Flow rate (l/min)	Port size	Pressure ratio	Circuit Symbol
VBA11A-F02	0.2 - 2.0	70	G1/4"	max. 4 : 1	
VBA10A-F02		230			
VBA20A-F03	0.2 - 1.0	1000	G3/8"	max. 2 : 1	
VBA22A-F03					
VBA40A-F04		1900	G1/2"		
VBA42A-F04					
VBA43A-F04	0.2 - 1.6	1600			

Accessories

Model	VBA10A-F02 VBA11A-F02	VBA20A-F03	VBA22A-F03	VBA40A-F04 VBA42A-F04	VBA43A-F04
Pressure gauge	G27-20-01	G36-10-01	KT-VBA22A-7	G36-10-01	G27-20-01
Silencer	AN20-02	AN30-03		AN40-04	
High noise reduction silencer	ANA1-02	ANA1-03		ANA1-04	
Air tank	VBAT05AF-SV-Q VBAT10AF-SV-Q	VBAT10AF-SV-Q VBAT20AF-RV-Q VBAT38AF-RV-Q		VBAT20AF-RV-Q VBAT38AF-RV-Q	-

5 Energy Saving Cylinders and Accessories

Purpose

Reduction of air consumption by actuators.

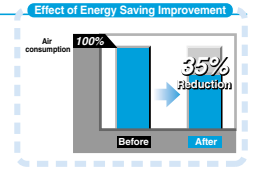

Before improvement

Non-optimised consumption of air in cylinders.

After improvement

The performance of a double power extension cylinder, series MGZ, requires lower operating pressure than a conventional cylinder.

Air saving valves, series ASR and ASQ, enable a 40% reduction in air consumption.

Also, compact solutions such as CVQ series, integrating a valve and a compact cylinder in one product, allow a considerable reduction in air consumption and piping requirements.

Double Power Cylinder Series MGZ/MGZR



- Double-acting double power cylinder.
- Highly loadable as a result of integrated slide bearing.
- Non-rotating rod (MGZ) - by slide bearing with built-in non-rotating mechanism.
- Double extension output power by "piston in piston construction".
- Approx. 30% reduced overall length compared with standard cylinders in tandem arrangement.
- Moment absorption is the same as guide cylinders (e.g. MGP), but with a 40% reduced overall width.
- Improved non-rotating accuracy: $\pm 0,3^\circ$ ($\pm 0,4^\circ$ for $\varnothing 20, 25$).
- Optimum design by the use of profile tube, auto switch can be integrated in grooves.
- Simple piping connection via 2 ports, resulting from internal air channels.
- Pre-cut mounting threads in cylinder covers and piston rod.

Part number	Ø (mm)	Standard strokes (mm)	Theoretical output, extension stroke (N) at 0,6MPa	Cushion	Type	Port Size	
MGZ20 - *	20	75, 100, 125, 150, 175, 200, 250, 300	436	Rubber bumper	With non-rotating mechanism	M5	
MGZ25TF - *	25		651			G1/8"	
MGZ32TF - *	32		973			G1/8"	
MGZ40TF - *	40		1520			G1/4"	
MGZ50TF - *	50		2309				
MGZ63TF - *	63		3567				
MGZ80TF - *	80		5829		Without non-rotating mechanism	G3/8"	
MGZR20 - *	20		Long stroke version up to 1000 mm available (800 mm for $\varnothing 20, \varnothing 25$)			436	M5
MGZR25TF - *	25					651	G1/8"
MGZR32TF - *	32					973	G1/8"
MGZR40TF - *	40	1520		G1/4"			
MGZR50TF - *	50	2309					
MGZR63TF - *	63	3567					
MGZR80TF - *	80	5829		G3/8"			

* Stroke length
Mounting elements such as foot brackets, flanges on request

Possible auto switches/accessories

Type	MGZ Ø 20, 25, 32 mm	MGZ Ø 40-80 mm
Reed switch	D-A93L, D-A90L	D-A93L, D-A90L
3-wire solid state PNP	D-M9PWL	D-M9PWL
2-wire solid state	D-M9BWL	D-M9BWL
Auto switch spacer	BMV3-016	BMG2-012

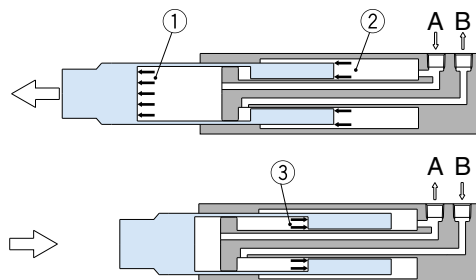

■ Air Saving Valve

Series ASR (Pressure Valve)
Series ASQ (Flow Valve)



- 40% reduction in air consumption

Pressure valve / Series ASR

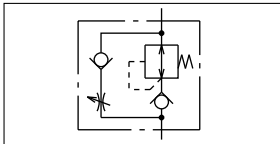

Flow valve / Series ASQ

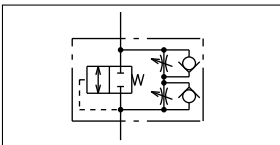

Integrated display type

Part number		Port size	Applicable tubing O.D. (mm)			
Pressure Valve	Flow valve		6	8	10	12
ASR430F-02-□S	ASQ430F-02-□S	R1/4"	●	●	●	
ASR530F-02-□S	ASQ530F-02-□S	R1/4"	●	●	●	●
ASR530F-03-□S	ASQ530F-03-□S	R3/8"	●	●	●	●
ASR630F-03-□S	ASQ630F-03-□S	R3/8"			●	●
ASR630F-04-□S	ASQ630F-04-□S	R1/2"			●	●

□ : Add applicable tubing O.D. (mm)

Cuts air consumption by operating the return stroke at a reduced pressure.

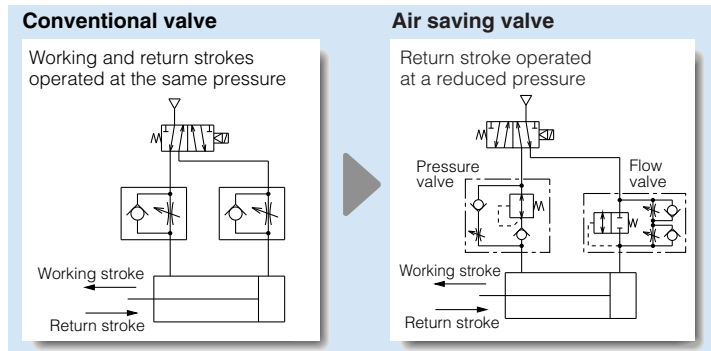

Working principle

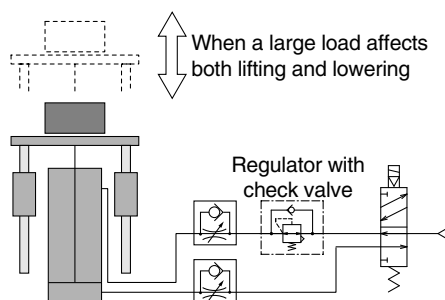

Cylinder performance comparison

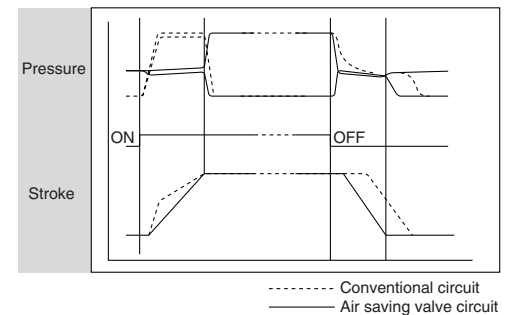

■ Compact Cylinder with Solenoid Valve

Series CVQ



- A double acting compact cylinder with integrated solenoid valve (2 positions single solenoid type).
- Space, energy and labour saving.
- Improved response speed.
- Different piping directions are possible.
- Two sizes: $\phi 32$ and $\phi 40$ mm.
- Enclosure: IP40.

Part number	Bore size (mm)	Port size ϕ (mm)	Rated voltage	Electrical entry
CVQB32-*-5MO	32	4	24 V DC	M-type plug connector without connector
CVQB40-*-5MO	40			

* Stroke

Bore size (mm)	Standard stroke								
	5	10	15	20	25	30	40	50	75
32		●	●	●	●	●	●	●	●
40	●	●	●	●	●	●	●	●	

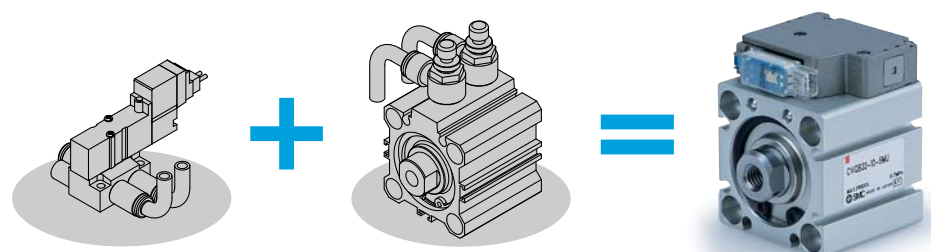

6 Vacuum Equipment

Purpose

Reduction of air consumption in vacuum applications.

Before improvement

Suction of a workpiece under leakage conditions requires large suction flow which, in turn, demands the use of a larger nozzle and increased air consumption.

After improvement

The use of a 3-stage ejector, Series ZL, enables the reduction of air consumption even under the same suction flow and vacuum pressure conditions.

INO-3769-□ vacuum pads with valve enable suction of the workpiece at the moment of contact with the pad and not previously, with the subsequent air consumption.

Specials of the series ZM, vacuum ejector with check valve enable stopping air supply to maintain the suction of the workpiece. Air consumption is reduced by shortening the vacuum generation time.

Vacuum Ejector

Series ZL



- Compact design.
- 3 different types:
Ejector + vacuum switch.
Ejector + vacuum gauge.
Only ejector
- Vacuum built by 3 stage ejector therefore less air consumption, by the nozzle.
- Nozzle diameter 1.2 mm.
- Suction capacity 100 ℓ/min or 200 ℓ/min with ZL212.
- Different ways of fixing to body.

Nozzle Ø [mm]	Type number	Type	Switch output	Suction cap. (ℓ/min)	Max. Vacuum Pressure
1.2	ZL112-Q	Standard	—	100	-84 kPa
	ZL112-G-Q	Standard with vacuum pressure gauge	—		
	ZL112-DPL-Q	Standard with vacuum switch	PNP		
	ZL112-DNL-Q		NPN		
	ZL112-DEL-Q		PNP + (1-5 V)		
	ZL112-K15LOZ-DPL-Q	Standard with vacuum switch and control valves	2 PNP		
	ZL112-K15LOZ-DNL-Q		2 NPN		
ZL112-K15LOZ-DEL-Q	PNP + (1-5 V)				
2 x 1.2	ZL212-Q	Standard	—	200	-84 kPa
	ZL212-G-Q	Standard with vacuum pressure gauge	—		
	ZL212-DPL-Q	Standard with vacuum switch	PNP		
	ZL212-DNL-Q		NPN		
	ZL212-DEL-Q		PNP + (1-5 V)		

	Cable L= 0.6 m	Cable L= 1 m	Cable L= 2 m	Cable L= 3 m
Without casing	SY100-30-4A-6	SY100-30-4A-10	SY100-30-4A-20	SY100-30-4A-30

Air consumption before and after using ZL

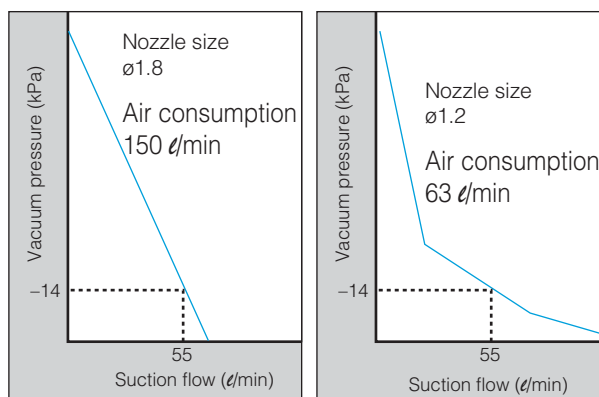

Working principle of a 3-stage vacuum ejector

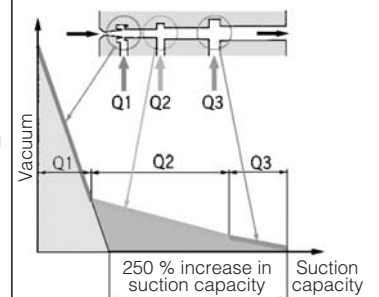

■ Vacuum Pad with Check Valve

Series INO-3769

Special Order Product

- The valve opens only when the pad end pin contacts the workpiece, and vacuum is generated.
- When multiple pads are used in the branch piping, vacuum level is not reduced even in case of vacuum failure or change in the workpiece size.

Part number	Pad diameter Ø, [mm]	Pad shape	Material	Others
INO-3769-1321-10CN	10	Flat with ribs	NBR	Vacuum entry: Rc 1/8"
INO-3769-1321-13CN	13			
INO-3769-1321-16CN	16			
INO-3769-1494-20CN-B01	20			
INO-3769-1494-25CN-B01	25			
INO-3769-1494-32CN-B01	32	Flat	Silicon rubber	
INO-3769-2431-06UN	6			
INO-3769-2431-08UN	8			
INO-3769-2431-08US	8			

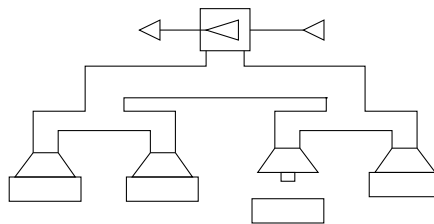

■ Vacuum Ejector with Check Valve

Series ZM

Special Order Product

ZM ** 1 * -B5LZ-EL-X142-Q**

Nozzle diameter, Ø	
05	0.5 mm (H type only)
07	0.7 mm (except S type)
10	1.0 mm (except S type)
13	1.3 mm
15	1.5 mm (S type only)

Body type
Conforms to the standard product

Standard supply pressure	
H	0.5 MPa
M	0.35 MPa (except 15)
S	0.45 MPa (13, 15 only)

CE marked

Switch type
Conforms to the standard product

Electrical entry
Conforms to the standard product

Power supply voltage
24 V DC

With N.O. air supply valve / N.O. type vacuum release valve

Before using ZM - continuous supply of air is required

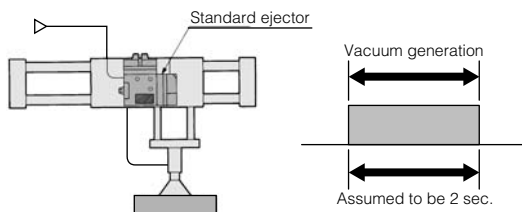

After using ZM - air consumption is reduced by shortening the vacuum generation time. Suction is achieved with no continuous supply of air.

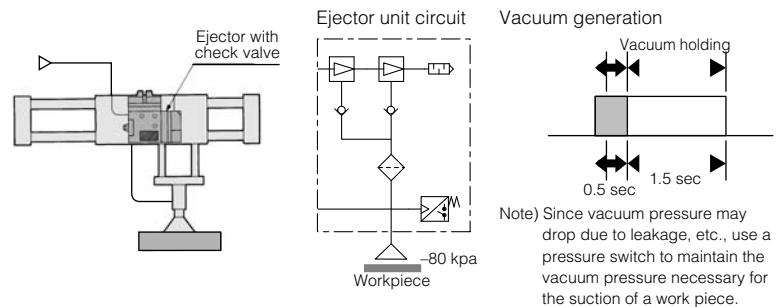

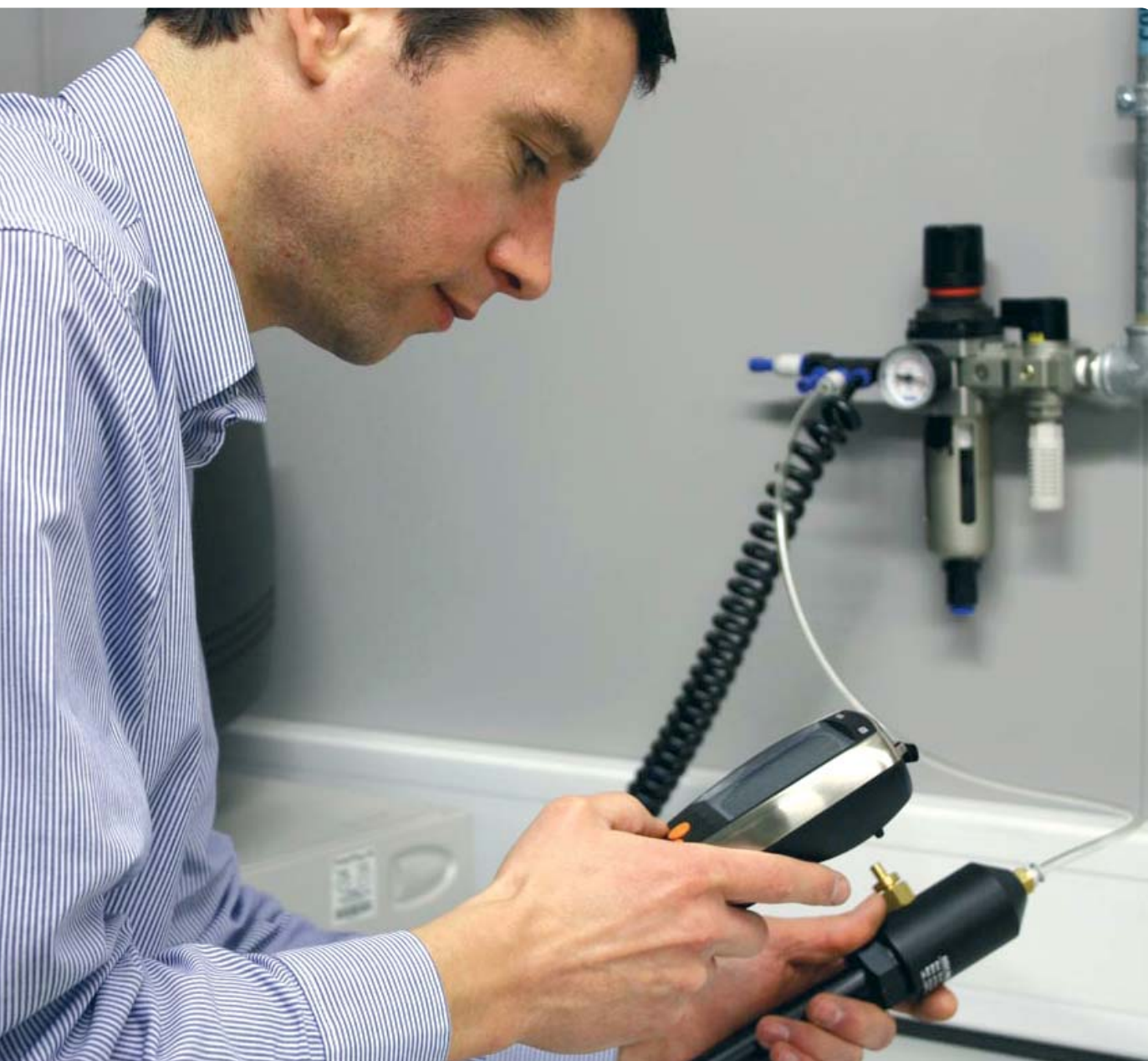

<http://energysaving.smc.eu>

SMC CORPORATION (Europe)

Austria	☎ +43 2262622800	www.smc.at	office@smc.at	Lithuania	☎ +370 52648126		
Belgium	☎ +32 (0)33551464	www.smc-pneumatics.be	info@smc-pneumatics.be	Netherlands	☎ +31 (0)205318888	www.smc-pneumatics.nl	info@smc-pneumatics.nl
Bulgaria	☎ +359 29744492	www.smc.bg	office@smc.bg	Norway	☎ +47 67129020	www.smc-norge.no	post@smc-norge.no
Croatia	☎ +385 13776674	www.smc.hr	office@smc.hr	Poland	☎ +48 222119600	www.smc.pl	office@smc.pl
Czech Republic	☎ +420 541424611	www.smc.cz	office@smc.cz	Romania	☎ +351 226166570	www.smc.eu	postpt@smc-smces.es
Denmark	☎ +45 70252900	www.smc.dk	smc@smc.dk	Russia	☎ +40 213205111	www.smcromania.ro	smcromania@smcromania.ro
Estonia	☎ +372 6510370	www.smc-pneumatics.ee	smc@smc-pneumatics.ee	Slovakia	☎ +7 8121185445	www.smc-pneumatik.ru	info@smc-pneumatik.ru
Finland	☎ +358 207513513	www.smc.fi	smcli@smc.fi	Slovenia	☎ +421 413213212	www.smc.sk	office@smc.sk
France	☎ +33 (0)164761000	www.smc-france.fr	contact@smc-france.fr	Spain	☎ +386 73885412	www.smc.si	office@smc.si
Germany	☎ +49 (0)61034020	www.smc-pneumatik.de	info@smc-pneumatik.de	Switzerland	☎ +34 945184100	www.smc.eu	post@smc-smces.es
Greece	☎ +30 210 2717265	www.smchellas.gr	sales@smchellas.gr	Sweden	☎ +46 (0)86031200	www.smc.nu	post@smc-pneumatics.se
Hungary	☎ +36 23511390	www.smc.hu	office@smc.hu	Switzerland	☎ +41 (0)523963131	www.smc.ch	info@smc.ch
Ireland	☎ +353 (0)14039000	www.smc-pneumatics.ie	sales@smc-pneumatics.ie	Turkey	☎ +90 (0)2124440762	www.entek.com.tr	smc@entek.com.tr
Italy	☎ +39 (0)292711	www.smcitalia.it	mailbox@smcitalia.it	UK	☎ +44 (0)8001382930	www.smc-pneumatics.co.uk	sales@smc-pneumatics.co.uk
Latvia	☎ +371 7817700	www.smc.lv	info@smclv.lv				

ES01A-UK