

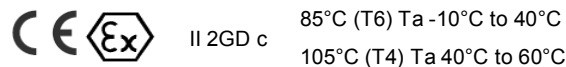

## Installation and Maintenance Manual

### Air cylinder

#### Series 55-C55



II 2GD c 85°C (T6) Ta -10°C to 40°C  
105°C (T4) Ta 40°C to 60°C

Marking description  
Group II, Category 2  
Suitable for Gas and Dust environment  
Type of protection "constructional safety"  
The maximum surface temperature is 85°C and the temperature class is T6 when the ambient temperature is: -10°C to 40°C  
The maximum surface temperature is 105°C and the temperature class is T4 when the ambient temperature is 40°C to 60°C

## 1 Safety Instructions

This manual contains essential information for the protection of users and others from possible injury and/or equipment damage.

- Read this manual before using the product, to ensure correct handling, and read the manuals of related apparatus before use.
- Keep this manual in a safe place for future reference.
- These instructions indicate the level of potential hazard by label of "Caution", "Warning" or "Danger", followed by important safety information which must be carefully followed.
- To ensure safety of personnel and equipment the safety instructions in this manual and the product catalogue must be observed, along with other relevant safety practices.

	<b>Caution</b>	Indicates a hazard with a low level of risk, which if not avoided, could result in minor or moderate injury.
	<b>Warning</b>	Indicates a hazard with a medium level of risk, which if not avoided, could result in death or serious injury.
	<b>Danger</b>	Indicates a hazard with a high level of risk, which if not avoided, will result in death or serious injury.

### Warning

- The compatibility of pneumatic equipment is the responsibility of the person who designs the pneumatic system or decides its specifications. Since the products specified here can be used in various operating conditions, their compatibility with the specific pneumatic system must be based on specifications or after analysis and/or tests to meet specific requirements.
- **Only trained personnel should operate pneumatically operated machinery and equipment.**  
Compressed air can be dangerous if an operator is unfamiliar with it. Assembly, handling or repair of pneumatic systems should be performed by trained and experienced personnel.
- **Do not service machinery/equipment or attempt to remove components until safety is confirmed.**
  - 1) Inspection and maintenance of machinery/equipment should only be performed after confirmation of safe locked-out control positions.
  - 2) When equipment is to be removed, confirm the safety process as mentioned above. Switch off air and electrical supplies and exhaust all residual compressed air in the system.
  - 3) Before machinery/equipment is re-started, ensure all safety measures to prevent sudden movement of cylinders etc. (Supply air into the system gradually to create back pressure, i.e. incorporate a soft-start valve).
- **Do not use this product outside of the specifications. Contact SMC if it is to be used in any of the following conditions:**
  - 1) Conditions and environments beyond the given specifications, or if the product is to be used outdoors.

## 1 Safety Instructions (Continued)

- 2) Installations in conjunction with atomic energy, railway, air navigation, vehicles, medical equipment, food and beverage, recreation equipment, emergency stop circuits, press applications, or safety equipment.
- 3) An application, which has the possibility of having negative effects on people, property, or animals, requiring special safety analysis.

### Caution

- Ensure that the air supply system is filtered to 5 microns.

## 2 Specifications

### 2.1 Specifications

Refer to the operation manual for this product.

Fluid		Air
Max. operating pressure	Ø20 ~ Ø100	1.0 MPa
Min. operating pressure	Ø20 ~ Ø100	0.05 MPa
Ambient and fluid temperature		-10 ~ 60°C
Lubrication		Not required
Operating piston speed	Ø20 ~ Ø100	50 ~ 500 mm/s
Cushion	Ø20 ~ Ø100	Rubber bumper
Allowable kinetic energy	Ø20	0.110 J
	Ø25	0.18 J
	Ø32	0.29 J
	Ø40	0.52 J
	Ø50	0.91 J
	Ø63	1.54 J
	Ø80	2.71 J
Ø100	4.54 J	
Explosive atmosphere		Gas and Dust
Zone		1, 21, 2 and 22

### 2.2 Production batch code

The production batch code printed on the label indicates the month and year of production as per the following table:

Year		2003	2004	2005	...	2021	2022	2023	...
Month		H	I	J	...	Z	A	B	...
Jan	O	HO	IO	JO	...	ZO	AO	BO	...
Feb	P	HP	IP	JJ	...	ZP	AP	BP	...
Mar	Q	HQ	IQ	JJ	...	ZQ	AQ	BQ	...
Apr	R	HR	IR	JR	...	ZR	AR	BR	...
May	S	HS	IS	JS	...	ZS	AS	BS	...
Jun	T	HT	IT	JT	...	ZT	AT	BT	...
Jul	U	HU	IU	JU	...	ZU	AU	BU	...
Aug	V	HV	IV	JV	...	ZV	AV	BV	...
Sep	W	HW	IW	JW	...	ZW	AW	BW	...
Oct	X	HX	IX	JX	...	ZX	AX	BX	...
Nov	Y	HY	IY	JY	...	ZY	AY	BY	...
Dec	Z	HZ	IZ	JZ	...	ZZ	AZ	BZ	...

## 3 Installation

### 3.1 Installation

#### Warning

- Do not install the product unless the safety instructions have been read and understood.

### 3.2 Environment

#### Warning

- Do not use in an environment where corrosive gases, chemicals, salt water or steam are present.
- Do not use in an explosive atmosphere except within the specified rating.
- Do not expose to direct sunlight. Use a suitable protective cover.
- Do not install in a location subject to vibration or impact. Check the product specifications.

## 3 Installation (Continued)

- Do not mount in a location exposed to radiant heat.
- Do not use in case of heavy dusty environment where dust can penetrate into the cylinder and dry the grease.
- Do not use in wet environments.

### 3.3 Piping

#### Caution

- Before piping make sure to clean up chips, cutting oil, dust etc.
- When installing piping or fittings, ensure sealant material does not enter inside the port. When using seal tape, leave 1.5 to 2 threads exposed on the end of the pipe/fitting.

Model	Port size
55-C55*-20	M5 x 0.8
55-C55*-25	
55-C55*-32	G1/8
55-C55*-40	
55-C55*-50	
55-C55*-63	
55-C55*-80	
55-C55*-100	

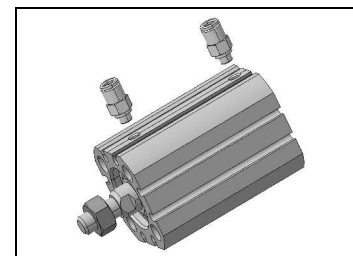

### 3.4 Lubrication

#### Caution

- SMC products have been lubricated for life at manufacture, and do not require lubrication in service.
- If a lubricant is used in the system, use turbine oil Class 1 (no additive), ISO VG32. Once lubricant is used in the system, lubrication must be continued because the original lubricant applied during manufacturing will be washed away.

### 3.5 Electrical connection

#### Warning

- Provide a grounding connection to the actuator to avoid any spark arising from potential differences.

### 3.6 Mounting accessories

#### Foot brackets

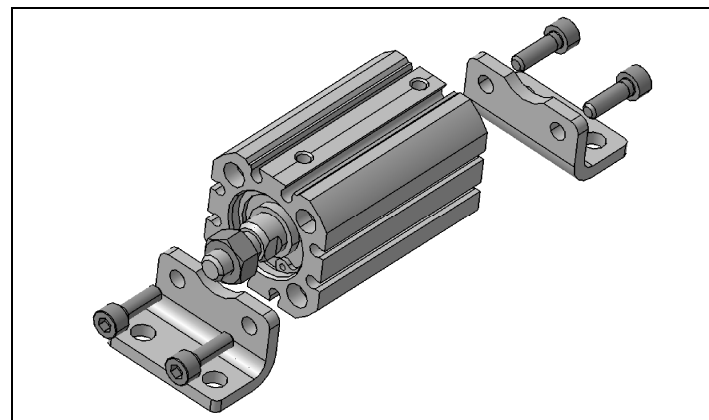

## 3 Installation (Continued)

#### Front flange

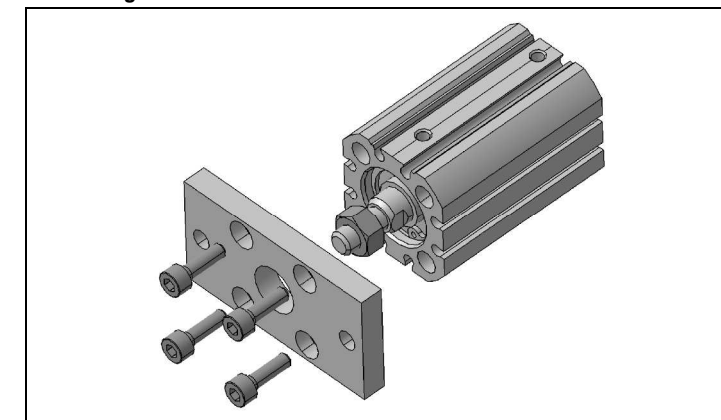

#### Rear flange

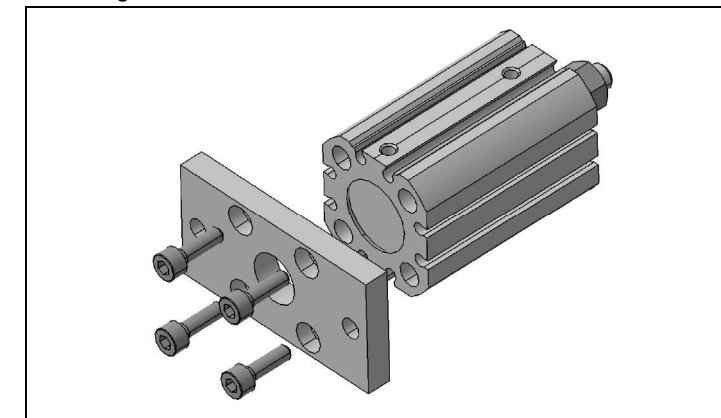

#### Rear single clevis

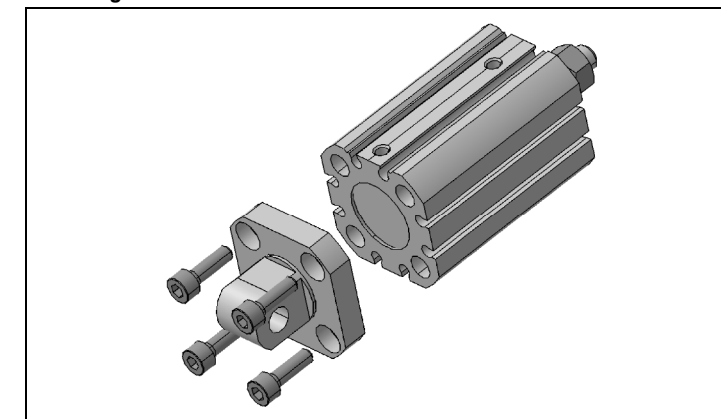

- When replacing brackets, use the hexagon wrenches shown below.

Bore size (mm)	Width across flats (mm)	Tightening torque (Nm)
Ø20 ~ Ø25	4	3 to 5.4
Ø32 ~ Ø40	4	8.98 to 12.0
Ø50 ~ Ø63	5	11.4 to 22.4
Ø80, Ø100	6	25.0 to 44.9

## 4 Settings

Refer to the operation manual for this product.

## 5 How to order

Refer to the operation manual for this product.

## 6 Outline dimensions

Refer to the operation manual for this product.

## 7 Maintenance

### 7.1 General Maintenance

#### ⚠ Caution

- Not following proper maintenance procedures could cause the product to malfunction and lead to equipment damage.
- If handled improperly, compressed air can be dangerous. Maintenance of pneumatic systems should be performed only by qualified personnel.
- Before performing maintenance, turn off the power supply and be sure to cut off the supply pressure. Confirm that the air is released to atmosphere.
- After installation and maintenance, apply operating pressure and power to the equipment and perform appropriate functional and leakage tests to make sure the equipment is installed correctly.
- Do not make any modification to the product.
- Do not disassemble the product, unless required by installation or maintenance instructions.
- Periodically check the rod surface, the rod seal and the cylinder tube external surface. Any damage or rust appearing on these components could increase friction and lead to dangerous conditions. Replace the whole actuator if any of these conditions should appear.
- Replace the seals, when air leakage is above allowable value given in the table below.

Internal leakage	10 cm <sup>3</sup> /min (ANR)
External leakage	5 cm <sup>3</sup> /min (ANR)

- Do not allow dust to form deposits on the outer surface of the actuator and mounting bracket.
- Periodically check for presence of lubrication.

### 7.2 Seal replacement

#### ⚠ Warning

- Only use SMC seal kits as listed in the table below.

Bore size (mm)	Seal kit number
Ø20	CQ2B20-PS
Ø25	CQ2B25-PS
Ø32	CQ2B32-PS
Ø40	CQ2B40-PS
Ø50	CQ2B50-PS
Ø63	CQ2B63-PS
Ø80	CQ2B80-PS
Ø100	CQ2B100-PS

### 7.3 Disassembly procedure

- Disassemble the cylinder, remove the old grease and place all the parts on a clean cloth in a clean environment.
- The snap ring pliers shall be used to remove snap ring.
- Remove the old tube gaskets, rod seal, piston seal, wear ring, using a fine screwdriver where necessary. If the magnet is present on the piston, do not remove it. This part is not to be replaced.

Model: C(D)55(B)20~100-\*(M)

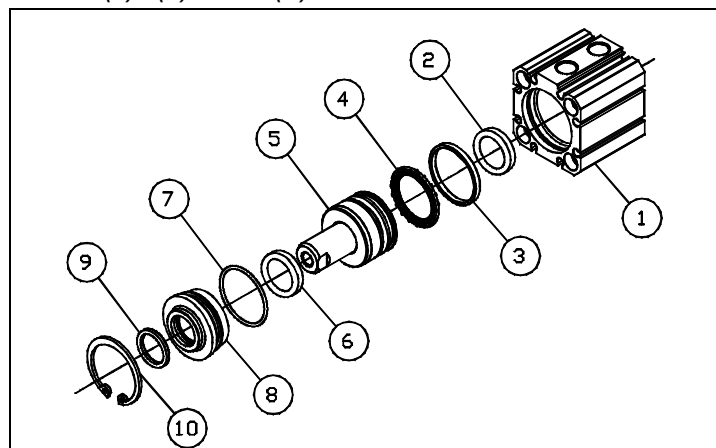

## 7 Maintenance (Continued)

1	Cylinder tube assembly	6	Bumper A
2	Bumper B	7	Tube gasket
3	Wear ring (Ø20 to Ø63 bore only)	8	Collar assembly
4	Piston seal	9	Rod seal
5	Piston/rod assembly	10	Retaining ring

### 7.4 Lubrication procedure

- Apply lubricant to:
  - rod seal
  - rod seal groove on the rod cover
  - piston outer surface
  - piston seal groove
  - piston seal inner and outer surface
  - tube gaskets
  - piston rod surface
  - tube inner surface
- Lubricate the parts using the following SMC grease packs:

Product	Grease pack number	Weight (g)
Standard	GR-S-010	10
	GR-S-020	20

- The amount of lubricant to be applied is listed in the following table.

Bore size (mm)	Required amount of grease for the minimum stroke (g)	Additional amount of grease required for each 5mm of stroke (g)
Ø20	5 mm stroke	0.12
Ø25		0.18
Ø32		0.25
Ø40		0.36
Ø50	10 mm stroke	0.665
Ø63		0.77
Ø80		1.14
Ø100		1.51

### 7.5 Assembly procedure

- Inserting the collar assembly into the piston rod assembly.
- Apply grease to the end of the piston rod, especially on the 30° chamfer and on the flats. Insert with care the piston rod into the rod cover to prevent any damage to the rod seal.
- Inserting piston rod assembly and rod cover assembly into the cylinder tube.

Insert slowly with care the piston assembly and the rod cover assembly into the cylinder tube to prevent any damage of the piston seal and tube gasket.

- Installing snap ring.

Use appropriate pliers (tool for C shape snap ring) for installation.

#### ⚠ Caution

When installing the snap ring, be aware that the snap ring may come off the pliers and could result in operator injury or equipment damage. Also make sure ring is firmly seated in ring groove.

- Checking assembly.

Make sure that no air is leaking from packing seals and that the cylinder operates smoothly at minimum operating pressure. Check for cylinder smooth movement and for air leakage.

## 8 Limitations of use

#### ⚠ Danger

- Do not exceed any of the specifications listed in section 2 of this document or the specific product catalogue.
- Air equipment has standard air leakage within certain limits. Do not use the equipment when the air itself can lead to explosion.
- Do not use this equipment where vibration could lead to equipment failure. Contact SMC for this specific situation.
- External impacts on the cylinder body could result in spark and/or cylinder damage. Avoid any application where foreign objects can hit the cylinder. In such situations install a suitable guard to prevent such impacts.
- Do not install or use this actuator in applications where the piston rod can impact foreign objects.
- Avoid applications where the piston rod end and the application joining parts create a possible ignition source.
- Use only ATEX certified auto switches. Order them separately.
- Do not use in the presence of strong magnetic fields that could generate a surface temperature higher than the value given for the temperature class.

## 9 Contacts

AUSTRIA	(43) 2262 62280-0	LATVIA	(371) 781 77 00
BELGIUM	(32) 3 355 1464	LITHUANIA	(370) 5 264 8126
BULGARIA	(359) 2 974 4492	NETHERLANDS	(31) 20 531 8888
CZECH REP.	(420) 541 424 611	NORWAY	(47) 67 12 90 20
DENMARK	(45) 7025 2900	POLAND	(48) 22 211 9600
ESTONIA	(372) 651 0370	PORTUGAL	(351) 21 471 1880
FINLAND	(358) 207 513513	ROMANIA	(40) 21 320 5111
FRANCE	(33) 1 6476 1000	SLOVAKIA	(421) 2 444 56725
GERMANY	(49) 6103 4020	SLOVENIA	(386) 73 885 412
GREECE	(30) 210 271 7265	SPAIN	(34) 945 184 100
HUNGARY	(36) 23 511 390	SWEDEN	(46) 8 603 1200
IRELAND	(353) 1 403 9000	SWITZERLAND	(41) 52 396 3131
ITALY	(39) 02 92711	UNITED KINGDOM	(44) 1908 563888

## SMC Corporation

URL : <http://www.smcworld.com> (Global) <http://www.smceu.com> (Europe)

Specifications are subject to change without prior notice from the manufacturer.

© 2011 SMC Corporation All Rights Reserved.