



Installation and Maintenance Manual

Rotary Actuator

Series 55-CRB2-Z

CE Ex II 2G c 130°C (T4) Ta 5°C to 40°C
150°C (T3) Ta 40°C to 60°C

Marking description
Group II, Category 2
Suitable for Gas environment
Type of protection "constructional safety"
Max surface temperature 130°C and temperature class T4 when ambient temperature is from 5°C to 40°C
Max surface temperature 150°C and temperature class T3 when ambient temperature is from 40°C to 60°C

1 Safety Instructions

This manual contains essential information for the protection of users and others from possible injury and/or equipment damage.

- Read this manual before using the product, to ensure correct handling, and read the manuals of related apparatus before use.
- Keep this manual in a safe place for future reference.
- These instructions indicate the level of potential hazard by label of "Caution", "Warning" or "Danger", followed by important safety information which must be carefully followed.
- To ensure safety of personnel and equipment the safety instructions in this manual and the product catalogue must be observed, along with other relevant safety practices.

	Caution	Indicates a hazard with a low level of risk, which if not avoided, could result in minor or moderate injury.
	Warning	Indicates a hazard with a medium level of risk, which if not avoided, could result in death or serious injury.
	Danger	Indicates a hazard with a high level of risk, which if not avoided, will result in death or serious injury.

Warning

- The compatibility of pneumatic equipment is the responsibility of the person who designs the pneumatic system or decides its specifications. Since the products specified here can be used in various operating conditions, their compatibility with the specific pneumatic system must be based on specifications or after analysis and/or tests to meet specific requirements.
- Only trained personnel should operate pneumatically operated machinery and equipment.** Compressed air can be dangerous if an operator is unfamiliar with it. Assembly, handling or repair of pneumatic systems should be performed by trained and experienced personnel.
- Do not service machinery/equipment or attempt to remove components until safety is confirmed.**
 - Inspection and maintenance of machinery/equipment should only be performed after confirmation of safe locked-out control positions.
 - When equipment is to be removed, confirm the safety process as mentioned above. Switch off air and electrical supplies and exhaust all residual compressed air in the system.
 - Before machinery/equipment is re-started, ensure all safety measures to prevent sudden movement of cylinders etc. (Supply air into the system gradually to create back pressure, i.e. incorporate a soft-start valve).
- Do not use this product outside of the specifications. Contact SMC if it is to be used in any of the following conditions:**
 - Conditions and environments beyond the given specifications, or if the product is to be used outdoors.
 - Installations in conjunction with atomic energy, railway, air navigation, vehicles, medical equipment, food and beverage, recreation equipment, emergency stop circuits, press applications, or safety equipment.
 - An application, which has the possibility of having negative effects on people, property, or animals, requiring special safety analysis

1 Safety Instructions (Continued)

Caution

- Ensure that the air supply system is filtered to 5 microns.

2 Specifications

2.1 Specifications

Refer to the operation manual for this product.

Single vane type					
Size	10	15	20	30	40
Operating fluid	Air (Non-lube)				
Max. operating pressure	0.7MPa			1.0MPa	
Min. operating pressure	0.2MPa	0.15MPa			
Ambient & fluid temp.	5-60°C				
Rotation angle (°)	90, 180, 270				
Port position	Side ported or Axial ported				
Port size (Side, Axial)	M3x0.5		M5x0.8		
Mounting	Basic style, Flange style				Basic
Output (Nm) **	0.12	0.32	0.7	1.83	3.73
Explosive atmosphere	Gas				
Zone	1 and 2				

Double vane type					
Size	10	15	20	30	40
Operating fluid	Air (Non-lube)				
Max. operating pressure	0.7MPa			1.0MPa	
Min. operating pressure	0.2MPa	0.15MPa			
Ambient & fluid temp.	5-60°C				
Rotation angle (°)	90, 100				
Port position	Side ported or Axial ported				
Port size	M3x0.5		M5x0.8		
Mounting	Basic style, Flange style				Basic
Output (Nm) **	0.25	0.65	1.45	3.7	7.59
Explosive atmosphere	Gas				
Zone	1 and 2				

** At 0.5MPa operating pressure

Warning

- Select a speed within the product's allowable kinetic energy limit.
- In case the kinetic energy exceeds the value given in the table, please contact SMC.
- Provide a shock absorber if the kinetic energy of the system connected to the product exceeds the allowable value.
- Do not stop or hold the product at the mid point by keeping air pressure in the product.
- If the product is used at low speed below the specified speed adjustment range, it could cause the product to stick slip, or to stop its movement.

Size	Allowable kinetic energy (J)				Safe adjustment range of rotating time
	Single vane		Double vane		
	No rubber cushion	Rubber cushion	No rubber cushion	Rubber cushion	
10	0.00015	-	0.0003	-	0.03-0.3
15	0.00025	0.001	0.0005	0.0012	
20	0.00040	0.003	0.0007	0.0033	
30	0.015	0.020	0.015	0.020	0.04-0.3
40	0.030	0.040	0.030	0.040	0.07-0.5

2.2 Production batch code

The production batch code printed on the label indicates the month and year of production as per the following table:

Production batch codes		2013	2014	2015	...	2021	2022	2023	...
Month	Year	R	S	T	...	Z	A	B	...
Jan		O	RO	SO	TO	...	ZO	AO	BO
Feb		P	RP	SP	TP	...	ZP	AP	BP
Mar		Q	RQ	SQ	TQ	...	ZQ	AQ	BQ
Apr		R	RR	SR	TR	...	ZR	AR	BR
May		S	RS	SS	TS	...	ZS	AS	BS
Jun		T	RT	ST	TT	...	ZT	AT	BT
Jul		U	RU	SU	TU	...	ZU	AU	BU
Aug		V	RV	SV	TV	...	ZV	AV	BV
Sep		W	RW	SW	TW	...	ZW	AW	BW
Oct		X	RX	SX	TX	...	ZX	AX	BX
Nov		Y	RY	SY	TY	...	ZY	AY	BY
Dec		Z	RZ	SZ	TZ	...	ZZ	AZ	BZ

3 Installation

3.1 Installation

Warning

- Do not install the product unless the safety instructions have been read and understood.
- Before operating the product by supplying air pressure, take appropriate measures to prevent the equipment from rotating unnecessarily.
- Do not enlarge the fixed throttle by modifying the pipe connectors.
- If shaft couplings are to be used, use those with angular freedom.

3.2 Environment

Warning

- Do not use in an environment where corrosive gases, chemicals, salt water or steam are present.
- Do not use in an explosive atmosphere except within the specified rating.
- Do not expose to direct sunlight. Use a suitable protective cover.
- Do not install in a location subject to vibration or impact. Check the product specifications.
- Do not mount in a location exposed to radiant heat.
- Do not use in case of heavy dusty environment where dust can penetrate into the actuator and dry the grease.
- Do not use in wet environments.

3.3 Piping and operating direction

Caution

- Before piping make sure to clean up chips, cutting oil, dust etc.
- When installing piping or fittings, ensure sealant material does not enter inside the port. When using seal tape, leave 1.5 to 2 threads exposed on the end of the pipe/fitting.

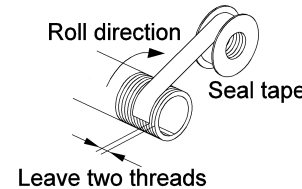

Size	Port size
10	M3x0.5,
15	
20	
30	M5x0.8
40	

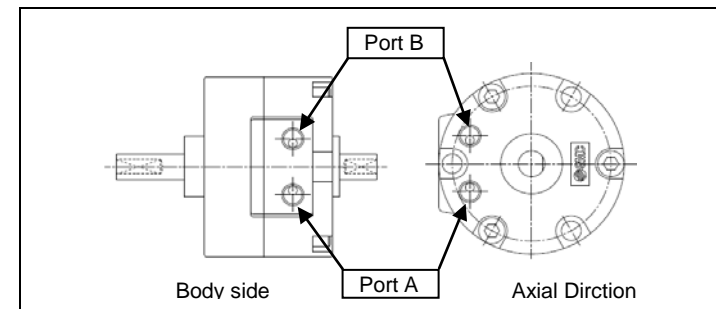

- The rotary actuator port is equipped with a fixed size orifice. Do not enlarge the hole. Enlarging the hole will increase the operation speed of the actuator and the consequent impact at the end of each stroke could lead to the actuator failure.
- The axis rotates clockwise when pressurized from A port.

3.4 Lubrication

Caution

- SMC products have been lubricated for life at manufacture, and do not require lubrication in service.
- If a lubricant is used in the system, use turbine oil Class 1 (no additive), ISO VG32. Once lubricant is used in the system, lubrication must be continued because the original lubricant applied during manufacturing will be washed away.

3.5 Electrical connection

Warning

- Provide a grounding connection to the actuator to avoid any spark arising from potential differences.

3.6 Mounting

Restrictions on the load applied to the shaft

- A static load, up to the values shown in the table below, can be applied to the actuator shaft, provided that a dynamic load is not generated. However, applications in which a load is directly applied to the shaft should be avoided as far as possible.

3 Installation (Continued)

Size	Allowable Load (N)	
	Fr *	Fsa & Fsb
10	14.7	9.8
15	14.7	9.8
20	24.5	19.6
30	29.4	24.5
40	60.0	40.0

(*) The point of application of the force Fr is the centre of the shaft flat or of the longer dimension of the key.

- In operating conditions, radial and axial load should be avoided. In order to improve operating conditions and to avoid direct loads on the shaft, a method such as that shown in the drawing below is recommended.

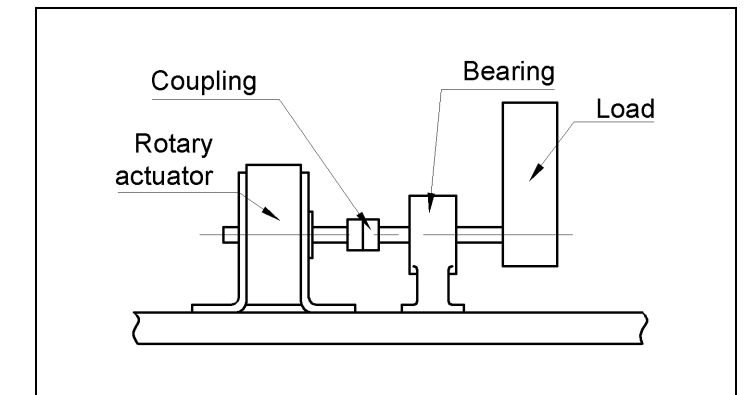
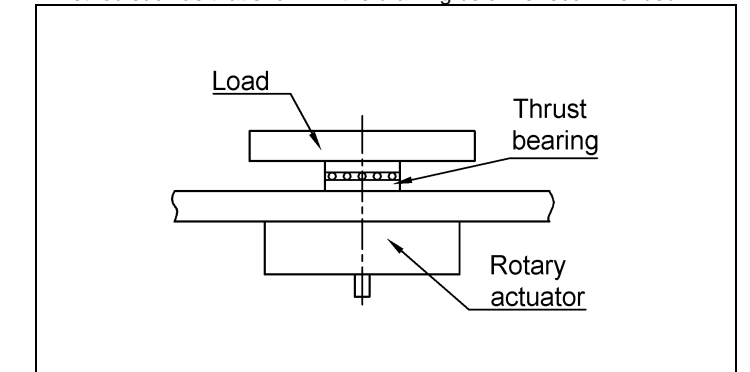

Axis fitting instruction

Alignment of the rotary actuator and the mating axis is necessary when the rotary actuator is used with its axis lengthened. If misaligned, partial load becomes high and the axis is applied with excessive bending moment. Under this condition, stable operation is not possible and the axis could be damaged. In this case, the use of a flexible joint becomes necessary.

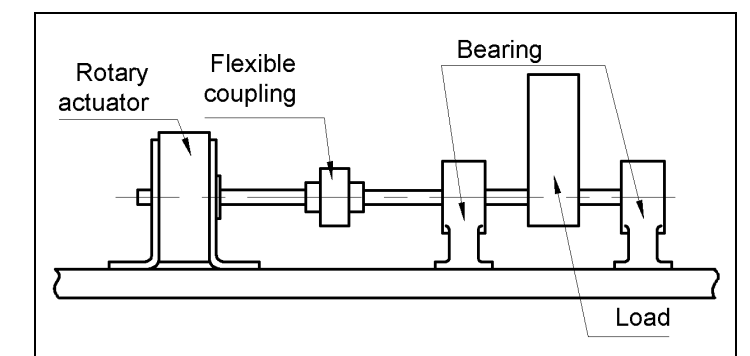

3 Installation (Continued)

Direct Mounting

Dimension 'L' of the actuators is provided in the table below for the use of standard hexagon socket head cap screws for direct mounting.

Size	L		Bolt
	Single vane	Double vane	
10	11.5	20.5	M2.5
15	16.0		M2.5
20	24.5		M3
30	34.5		M4
40	39.5		M4

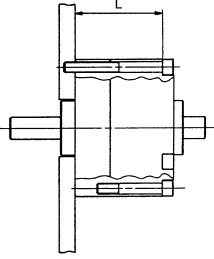

Flange Mounting

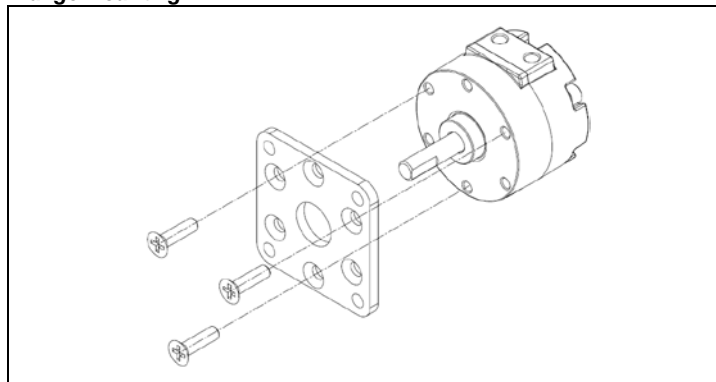

4 Settings

Refer to the operation manual for this product.

5 How to order

Refer to the operation manual for this product.

6 Outline dimensions

Refer to the operation manual for this product.

7 Maintenance

7.1 General Maintenance

⚠ Caution

- Not following proper maintenance procedures could cause the product to malfunction and lead to equipment damage.
- If handled improperly, compressed air can be dangerous. Maintenance of pneumatic systems should be performed only by qualified personnel.
- Before performing maintenance, turn off the power supply and be sure to cut off the supply pressure. Confirm that the air is released to atmosphere.
- After installation and maintenance, apply operating pressure and power to the equipment and perform appropriate functional and leakage tests to make sure the equipment is installed correctly.
- Do not make any modification to the product.
- Do not disassemble the product, unless required by installation or maintenance instructions. Products dismantled and re-assembled by end-users are not covered by the guarantee.
- Periodically check the shaft surface, and the actuator external surface. Any damage or rust appearing on these components could increase friction and lead to dangerous conditions. Replace the whole actuator if any of these conditions should appear.
- Do not allow dust to form deposits on the outer surface of the actuator and mounting bracket.
- Periodically check for presence of lubrication.

8 Limitations of use

⚠ Danger

- Do not exceed any of the specifications listed in section 2 of this document or the specific product catalogue.
- Air equipment has standard air leakage within certain limits. Do not use the equipment when the air itself can lead to explosion.
- Do not use this equipment where vibration could lead to equipment failure. Contact SMC for this specific situation.
- External impacts on the actuator body could result in spark and/or actuator damage. Avoid any application where foreign objects can hit the actuator. In such situations install a suitable guard to prevent such impacts.
- Avoid applications where the actuator shaft and the application joining parts create a possible ignition source.
- Do not use in the presence of strong magnetic fields that could generate a surface temperature higher than the value given for the temperature class

9 Contacts

AUSTRIA	(43) 2262 62280-0	LATVIA	(371) 781 77 00
BELGIUM	(32) 3 355 1464	LITHUANIA	(370) 5 264 8126
BULGARIA	(359) 2 974 4492	NETHERLANDS	(31) 20 531 8888
CZECH REP.	(420) 541 424 611	NORWAY	(47) 67 12 90 20
DENMARK	(45) 7025 2900	POLAND	(48) 22 211 9600
ESTONIA	(372) 651 0370	PORTUGAL	(351) 21 471 1880
FINLAND	(358) 207 513513	ROMANIA	(40) 21 320 5111
FRANCE	(33) 1 6476 1000	SLOVAKIA	(421) 2 444 56725
GERMANY	(49) 6103 4020	SLOVENIA	(386) 73 885 412
GREECE	(30) 210 271 7265	SPAIN	(34) 945 184 100
HUNGARY	(36) 23 511 390	SWEDEN	(46) 8 603 1200
IRELAND	(353) 1 403 9000	SWITZERLAND	(41) 52 396 3131
ITALY	(39) 02 92711	UNITED KINGDOM	(44) 1908 563888

SMC Corporation

URL : [http:// www.smcworld.com](http://www.smcworld.com) (Global) <http:// www.smceu.com> (Europe)

Specifications are subject to change without prior notice from the manufacturer.

© 2013 SMC Corporation All Rights Reserved.