



# Installation and Maintenance Manual

## Mechanically Jointed Rodless Cylinder

### Series 55-MY1H

II 2G c 75°C (T6) Ta 5°C to 40°C  
95°C (T5) Ta 40°C to 60°C

Marking description  
Group II, Category 2  
Suitable for Gas environment  
Type of protection "constructional safety"  
The maximum surface temperature is 75°C and the temperature class is T6 when the ambient temperature is: 5°C to 40°C  
The maximum surface temperature is 95°C and the temperature class is T5 when the ambient temperature is 40°C to 60°C

## 1 Safety Instructions

### 1.1 General recommendations

This manual contains essential information for the protection of users and others from possible injury and/or equipment damage.

- Read this manual before using the product, to ensure correct handling, and read the manuals of related apparatus before use.
- Keep this manual in a safe place for future reference.
- These instructions indicate the level of potential hazard by label of "Caution", "Warning" or "Danger", followed by important safety information which must be carefully followed.
- To ensure safety of personnel and equipment the safety instructions in this manual and the product catalogue must be observed, along with other relevant safety practices.

	<b>Caution</b>	Indicates a hazard with a low level of risk, which if not avoided, could result in minor or moderate injury.
	<b>Warning</b>	Indicates a hazard with a medium level of risk, which if not avoided, could result in death or serious injury.
	<b>Danger</b>	Indicates a hazard with a high level of risk, which if not avoided, will result in death or serious injury.

### Warning

- The compatibility of pneumatic equipment is the responsibility of the person who designs the pneumatic system or decides its specifications. Since the products specified here can be used in various operating conditions, their compatibility with the specific pneumatic system must be based on specifications or after analysis and/or tests to meet specific requirements.
- **Only trained personnel should operate pneumatically operated machinery and equipment.**  
Compressed air can be dangerous if an operator is unfamiliar with it. Assembly, handling or repair of pneumatic systems should be performed by trained and experienced personnel.
- **Do not service machinery/equipment or attempt to remove components until safety is confirmed.**
  - 1) Inspection and maintenance of machinery/equipment should only be performed after confirmation of safe locked-out control positions.
  - 2) When equipment is to be removed, confirm the safety process as mentioned above. Switch off air and electrical supplies and exhaust all residual compressed air in the system.
  - 3) Before machinery/equipment is re-started, ensure all safety measures to prevent sudden movement of cylinders etc. (Supply air into the system gradually to create back pressure, i.e. incorporate a soft-start valve).
- Do not use this product outside of the specifications. Contact SMC if it is to be used in any of the following conditions:
  - 1) Conditions and environments beyond the given specifications, or if the product is to be used outdoors.

## 1 Safety Instructions (Continued)

- 2) Installations in conjunction with atomic energy, railway, air navigation, vehicles, medical equipment, food and beverage, recreation equipment, emergency stop circuits, press applications, or safety equipment.
- 3) An application which has the possibility of having negative effects on people, property, or animals, requiring special safety analysis.

### Caution

Ensure that the air supply system is filtered to 5 microns.

### 1.2 Specific recommendations

#### Warning

#### • Intermediate stops.

When intermediate stopping of a cylinder piston is performed with a 3 position closed centre type directional control valve, it is difficult to achieve stopping positions as accurate and minute as with hydraulic pressure due to the compressibility of air. Furthermore, since valves and cylinders, etc., are not guaranteed for zero air leakage, and it is not possible to hold a stopped position, do not use for this purpose. In case it is necessary to hold a stopped position, select equipment and design circuits to prevent movement.

#### Caution

#### • Provide intermediate supports for long stroke cylinders.

Provide intermediate supports for cylinders with long strokes to prevent bending of the tube, and deflection due to vibration and external loads, etc.

## 2 Specifications

### 2.1 Specifications

Refer to the operation manual for this product.

Fluid	Air	
Max. operating pressure	0.8 MPa	
Min. operating pressure	Ø10	0.2 MPa
	Ø16~Ø40	0.1 MPa
Ambient and fluid temperature	5 to 60°C	

Lubrication	Not required	
Operating piston speed	Ø10	100 to 500 mm/s
	Ø16 ~Ø40	100 to 1000 mm/s
Cushion	Ø10	Rubber bumper
	Ø16~Ø40	Air cushion
Allowable kinetic energy	Ø10	0.02 J
	Ø16	0.6 J
	Ø20	1 J
	Ø25	1.7 J
	Ø32	3.4 J
	Ø40	6.2 J
Explosive atmosphere	Gas	
Zone	1 and 2	

### 2.2 Production batch code

Production batch codes									
Year	2003	2004	2005	...	2021	2022	2023	...	
Month	H	I	J	...	Z	A	B	...	
Jan	O	HO	IO	JO	...	ZO	AO	BO	...
Feb	P	HP	IP	JP	...	ZP	AP	BP	...
Mar	Q	HQ	IQ	JQ	...	ZQ	AQ	BQ	...
Apr	R	HR	IR	JR	...	ZR	AR	BR	...
May	S	HS	IS	JS	...	ZS	AS	BS	...
Jun	T	HT	IT	JT	...	ZT	AT	BT	...
Jul	U	HU	IU	JU	...	ZU	AU	BU	...
Aug	V	HV	IV	JV	...	ZV	AV	BV	...
Sep	W	HW	IW	JW	...	ZW	AW	BW	...
Oct	X	HX	IX	JX	...	ZX	AX	BX	...
Nov	Y	HY	IY	JY	...	ZY	AY	BY	...
Dec	Z	HZ	IZ	JZ	...	ZZ	AZ	BZ	...

## 3 Installation

### 3.1 Installation

#### Warning

- Do not install the product unless the safety instructions have been read and understood.

#### Warning

- **Do not apply strong impact or excessive moment to the slide table (slider).**

The slide table (slider) is supported by precision bearings. Therefore, do not apply strong impacts or excessive moment, etc., when mounting work pieces.

- **Align carefully when connecting to a load having an external guide mechanism.**

Mechanically jointed rodless cylinders can be used with a direct load within the allowable range for each type of guide, but careful alignment is necessary when connecting to a load having an external guide mechanism. As the stroke becomes longer, variations in the center axis become larger. Consider using a connection method (floating mechanism) that is able to absorb these variations. Furthermore, use the special floating brackets which have been designed for series MY1B.

- **Do not scratch or gouge the cylinder tube by striking or grasping it with other objects.**

Cylinder bores are manufactured to precise tolerances therefore even a slight deformation may cause malfunction.

- **Do not use until you can verify that equipment can operate properly.**

Verify correct mounting by suitable function and leakage inspections after compressed air and power are connected following mounting, maintenance or conversions.

- **Instruction Manual.**

The product should be mounted and operated after thoroughly reading the manual and understanding its contents. Keep the instruction manual where it can be referred to as needed.

### 3.2 Environment

#### Warning

- Do not use in an environment where corrosive gases, chemicals, salt water or steam are present.

- Do not use in an explosive atmosphere except within the specified rating.
- Do not expose to direct sunlight. Use a suitable protective cover.
- Do not install in a location subject to vibration or impact. Check the product specifications.
- Do not mount in a location exposed to radiant heat.
- Do not use in case of heavy dusty environment where dust can penetrate into the cylinder and dry the grease.
- Do not use in a wet environment.

### 3.3 Piping

#### Caution

- Before piping make sure to clean up chips, cutting oil, dust etc.
- When installing piping or fittings, ensure sealant material does not enter inside the port. When using seal tape, leave 1.5 to 2 threads exposed on the end of the pipe/fitting.

Bore size (mm)	Port size
Ø10, Ø16, Ø20	M5 x 0.8
Ø25 & Ø32	Rc, G or NTP 1/8
Ø40	Rc, G or NTP 1/4

### 3.4 Lubrication

#### Caution

- SMC products have been lubricated for life at manufacture, and do not require lubrication in service.
- If a lubricant is used in the system, use turbine oil Class 1 (no additive), ISO VG32. Once lubricant is used in the system, lubrication must be continued because the original lubricant applied during manufacturing will be washed away.

## 3 Installation (Continued)

### 3.5 Electrical connection

#### Warning

- Provide a grounding connection to the actuator to avoid any spark arising from potential differences.

### 3.6 Mounting accessories

#### Side support A

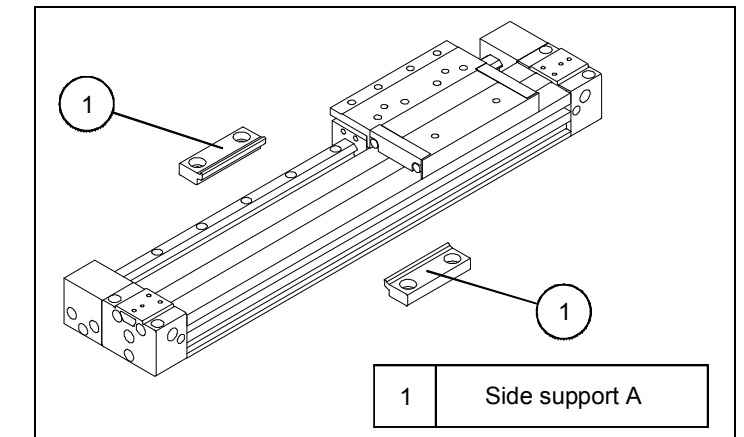

#### Side support B

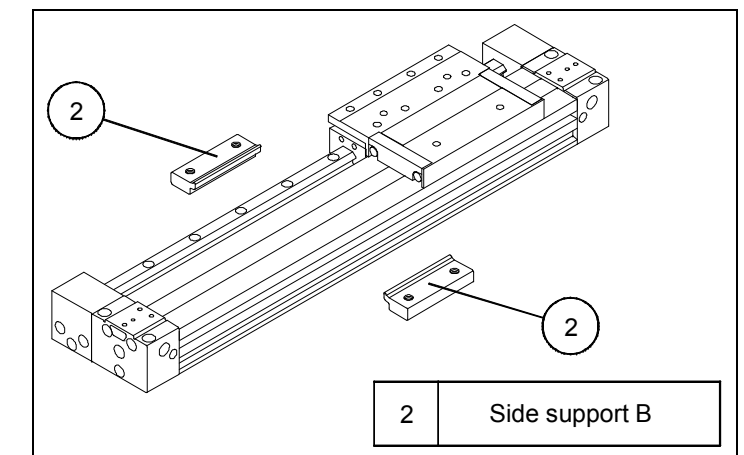

- When replacing side support, use the hexagonal socket head cap screws of the following sizes, and the hexagon wrenches shown below.

Bore size (mm)	Cap screw size		Width across flats (mm)	
	Side support A	Side support B	Side support A	Side support B
Ø10, Ø16	M3	M4	2.5	3
Ø20	M4	M5	3	4
Ø25	M5	M6	4	5
Ø32	M6	M8	5	6
Ø40	M8	M10	6	8

## 4 Settings

### 4.1 Air cushion adjustment

- For air-cushion adjustment, tighten or loosen the cushion valve using a hexagon socket wrench (excluding  $\varnothing 10$ ).

#### Warning

- Do not operate the cushion valve in the fully closed or fully opened state.
- Using it in the fully closed state will cause the cushion seal to be damaged. Using it in the fully opened state will cause the piston assembly or the cover to be damaged.
- Be certain to activate the air cushion at the stroke end.
- When the cylinder is used with the cushion valve in a fully open position, a suitable external device should be installed to absorb all of the kinetic energy of the mechanism, of which the actuator is part, before reaching each end of stroke. If this is not done, the piston assembly will be damaged.

Bore size (mm)	Width across flats (mm)
$\varnothing 16, \varnothing 20, \varnothing 25$	1.5
$\varnothing 32, \varnothing 40$	2.5

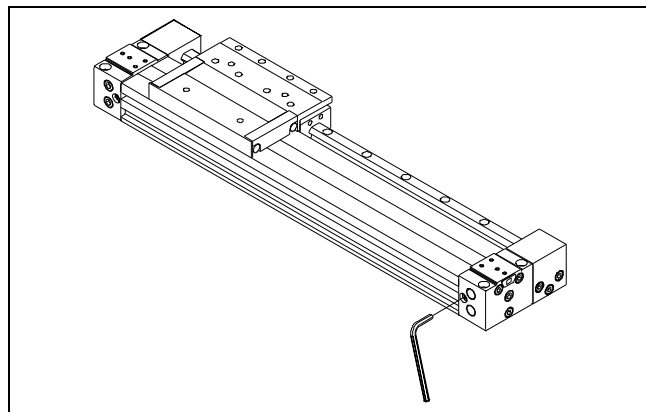

## 5 How to order

Refer to the operation manual for this product.

## 6 Outline dimensions

Refer to the operation manual for this product.

## 7 Maintenance

### 7.1 General Maintenance

#### Caution

- Not following proper maintenance procedures could cause the product to malfunction and lead to equipment damage.
- If handled improperly, compressed air can be dangerous. Maintenance of pneumatic systems should be performed only by qualified personnel.
- Before performing maintenance, turn off the power supply and be sure to cut off the supply pressure. Confirm that the air is released to atmosphere.
- After installation and maintenance, apply operating pressure and power to the equipment and perform appropriate functional and leakage tests to make sure the equipment is installed correctly.
- Do not make any modification to the product.
- Do not disassemble the product, unless required by installation or maintenance instructions.
- Periodically, check the cylinders external surface. Any damage or rust appearing on it, could increase friction, and lead to dangerous conditions. Replace the whole actuator, if any of these conditions should appear.

## 7 Maintenance (Continued)

### 7.2 Replacement of dust seal band

#### Warning

- The dust seal band is the only customer replaceable part. For replacement of other parts, please return the product to SMC for servicing.

Use only original SMC dust seal bands, given in the table below.

Bore size (mm)	Replacement part no.	Standard length
$\varnothing 10$	MY10-16B-stroke	Stroke+110
$\varnothing 16$	MY16-16B-stroke	Stroke+160
$\varnothing 20$	MY20-16B-stroke	Stroke+200
$\varnothing 25$	MY25-16B-stroke	Stroke+182
$\varnothing 32$	MY32-16B-stroke	Stroke+228
$\varnothing 40$	MY40-16B-stroke	Stroke+272

### 7.3 Disassembly procedure

- Disassemble the cylinder, remove the old grease and place all the parts on a clean cloth in a clean environment. The following flat head screwdriver or hexagon socket wrench shall be used to loosen the set screws:

Bore size (mm)	Head	Width across flats (mm)
$\varnothing 10$	Slotted	0.25
$\varnothing 16, \varnothing 20, \varnothing 25, \varnothing 32, \varnothing 40$	Hexagon socket	1.5

- The following screwdrivers or hexagon socket wrenches shall be used to loosen the end cover screws.

Bore size (mm)	Head	Width across recess and across flats (mm)
$\varnothing 10$	Cross recessed	2.2
$\varnothing 16, \varnothing 20$	Hexagon socket	2
$\varnothing 25, \varnothing 32, \varnothing 40$		2.5

- Remove the old dust seal band, scrapers and if necessary, bearings and side scrapers.

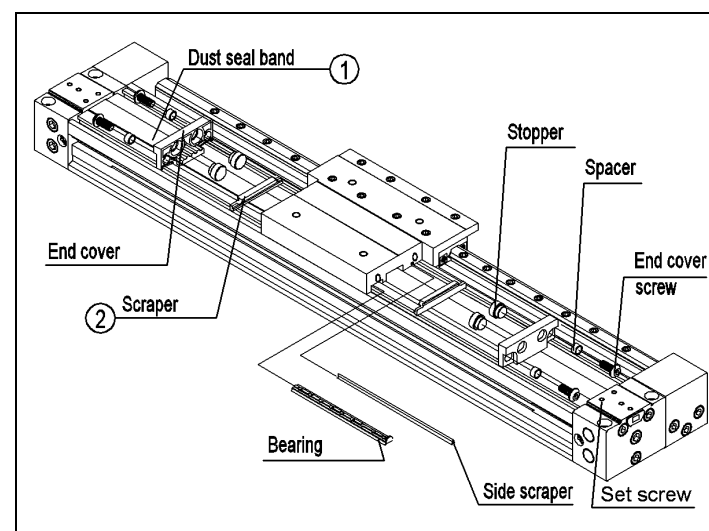

1	Dust seal band
2	Scraper

## 7 Maintenance (Continued)

### 7.4 Lubrication procedure

- Lubricate the parts using the following SMC grease packs:

Product	Grease pack number	Weight (g)
Standard	GR-S-010	10
	GR-S-020	20

- Apply lubricant to:
  - Dust seal band inner and outer surface
  - scrapers
  - bearings
  - side scrapers
  - tube top surface

### 7.5 Assembly procedure

- The cylinder is assembled in the following order: bearings, dust seal band, side scraper, parallel key, scraper, stopper, spacer and end cover. Tighten the cross recessed binding head screws or the hexagon socket button bolt according to the torque values given.

Bore size (mm)	Torque $\pm 10\%$ (N m)
$\varnothing 10$	0.15
$\varnothing 16, \varnothing 20$	0.3
$\varnothing 25, \varnothing 32, \varnothing 40$	0.7

- Finally tighten the two set screws at each side with tightening torque of 0.1 Nm.
- Check for cylinder smooth movement and for air leakage.

## 8 Limitations of use

#### Danger

- Do not exceed any of the specifications listed in section 2 of this document or the specific product catalogue.
- Air equipment has standard air leakage within certain limits. Do not use the equipment when the air itself can lead to explosion.
- Do not use this equipment where vibration could lead to equipment failure. Contact SMC for this specific situation.
- External impacts on the cylinder body could result in spark and/or cylinder damage. Avoid any application where foreign objects can hit the cylinder. In such situations install a suitable guard to prevent such impacts.
- Do not install or use this actuator in applications where the slide table can impact foreign objects.
- Avoid applications where the slide table, and the application joining parts create a possible ignition source.
- Use only ATEX certified auto switches. Order them separately.
- Do not use in the presence of strong magnetic fields that could generate a surface temperature higher than the value given for the temperature class.

## 9 Contacts

AUSTRIA	(43) 2262 62280-0	LATVIA	(371) 781 77 00
BELGIUM	(32) 3 355 1464	LITHUANIA	(370) 5 264 8126
BULGARIA	(359) 2 974 4492	NETHERLANDS	(31) 20 531 8888
CZECH REP.	(420) 541 424 611	NORWAY	(47) 67 12 90 20
DENMARK	(45) 7025 2900	POLAND	(48) 22 211 9600
ESTONIA	(372) 651 0370	PORTUGAL	(351) 21 471 1880
FINLAND	(358) 207 513513	ROMANIA	(40) 21 320 5111
FRANCE	(33) 1 6476 1000	SLOVAKIA	(421) 2 444 56725
GERMANY	(49) 6103 4020	SLOVENIA	(386) 73 885 412
GREECE	(30) 210 271 7265	SPAIN	(34) 945 184 100
HUNGARY	(36) 23 511 390	SWEDEN	(46) 8 603 1200
IRELAND	(353) 1 403 9000	SWITZERLAND	(41) 52 396 3131
ITALY	(39) 02 92711	UNITED KINGDOM	(44) 1908 563888

## SMC Corporation

URL : <http://www.smcworld.com> (Global) <http://www.smceu.com> (Europe)  
 Specifications are subject to change without prior notice from the manufacturer.  
 © 2011 SMC Corporation All Rights Reserved.