



Installation & Maintenance Manual
Digital Pressure Switch
Series 56-ISE70/ISE75/ISE75H

56-ISE70

CE II 3G Ex nA IIC T5 Gc X 0°C ≤ Ta ≤ 50°C
 II 3D Ex tc IIIC T53°C Dc X IP67

56-ISE75/ISE75H

CE II 3G Ex nA IIC T4 Gc X -5°C ≤ Ta ≤ 50°C
 II 3D Ex tc IIIC T54°C Dc X IP67

56-ISE70-*65-*X508

CE II 3G Ex nA IIC T4 Gc X 0°C ≤ Ta ≤ 50°C
 II 3D Ex tc IIIC T58°C Dc X IP67

Safety Instructions

This manual contains essential information for the protection of users and others from possible injury and/or equipment damage.
 •Read this manual before using the product, to ensure correct handling, and read the manuals of related apparatus before use.
 •Keep this manual in a safe place for future reference.
 •These instructions indicate the level of potential hazard by label of "Caution", "Warning" or "Danger", followed by important safety information which must be carefully followed.
 •To ensure safety of personnel and equipment the safety instructions in this manual and the product catalogue must be observed, along with other relevant safety practices.

Caution	CAUTION indicates a hazard with a low level of risk which, if not avoided, could result in minor or moderate injury.
Warning	WARNING indicates a hazard with a medium level of risk which, if not avoided, could result in death or serious injury.
Danger	DANGER indicates a hazard with a high level of risk which, if not avoided, will result in death or serious injury.

This product is class A equipment that is intended for use in an industrial environment.
 There may be potential difficulties in ensuring electromagnetic compatibility in other environments due to conducted as well as radiated disturbances.

Warning

- Do not disassemble, modify (including changing the printed circuit board) or repair. An injury or failure can result.
- Do not operate the product outside of the specifications. Do not use for flammable or harmful fluids. Fire, malfunction, or damage to the product can result. Verify the specifications before use.
- Do not operate in an atmosphere containing flammable or explosive gases. Fire or an explosion can result. This product is suitable for ATEX category 3 only.
- Do not use the product in a place where static electricity is a problem. Otherwise it can cause failure or malfunction of the system.
- If using the product in an interlocking circuit:
 - Provide a double interlocking system, for example a mechanical system.
 - Check the product regularly for proper operation. Otherwise malfunction can result, causing an accident.

Safety Instructions (continued)

Warning

- The following instructions must be followed during maintenance:
 - Turn off the power supply.
 - Stop the air supply, exhaust the residual pressure and verify that the air is released before performing maintenance. Otherwise an injury can result.

Caution

- Do not touch the terminals and connectors while the power is on. Otherwise electric shock, malfunction or damage to the product can result.
- After maintenance is complete, perform appropriate functional inspections and leak tests. Stop operation if the equipment does not function properly or there is a leakage of fluid. When leakage occurs from parts other than the piping, the product is faulty. Disconnect the power supply and stop the fluid supply. Do not apply fluid under leaking conditions. Safety cannot be assured in the case of unexpected malfunction.

ATEX Marking Description	
II 3G Ex nA IIC T5 Gc X 0°C ≤ Ta ≤ 50°C II 3D Ex tc IIIC T53°C Dc X IP67	
Equipment Group II	tc - protected by enclosure
Category 3	IIIC - for all types of dust
Gas (G) and Dust (D) environment	T??°C - Max. surface temperature
Ex - European standards apply	Gc/Dc - Equipment Protection Level
nA - Non-sparking apparatus	X - special conditions, see instructions
IIC - for all types of gas	
T5 - Temperature classification	Ta - ambient temperature
	IP67 - Protection structure

How to order

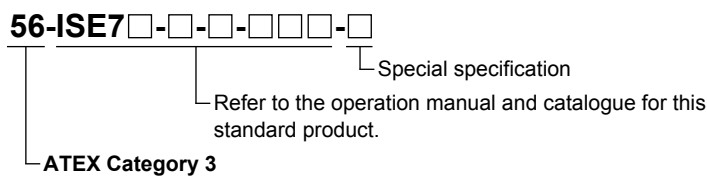

Summary of Product parts

- Indicator light (Green): Displays the operation condition of the Pressure switch. Lights ON when the output (OUT1) is turned ON.
- LCD display: Displays the current status of pressure, setting mode and error code. Four display modes can be selected: display always in red or green only, or changing from green to red, red to green linked to output.
- UP button: Increases the mode and ON/OFF set value. Press this button to change to the peak display mode.
- DOWN button: Decreases the mode and ON/OFF set value. Press this button to change to the bottom display mode.
- SET button: Press this button to change to another mode and to set a set value.

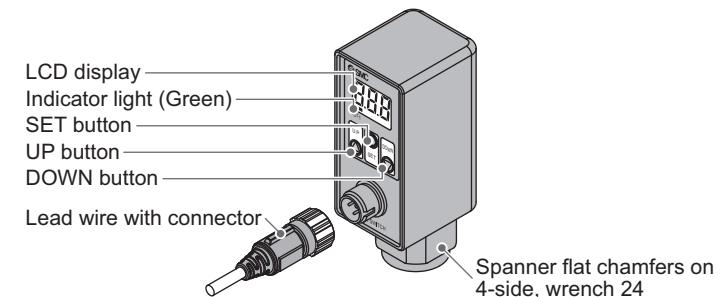

*: This picture applies to all output specifications except -27 and -67. (If the output specification shown in a part number is -27 or -67, the indicator light OUT2 (Red) is added.)

Installation

Piping

- Connect the fitting to piping.
- When piping, tighten to an appropriate torque of 13.6 to 15 Nm for ISE70 series and 25 to 28 Nm for ISE75/75H series.

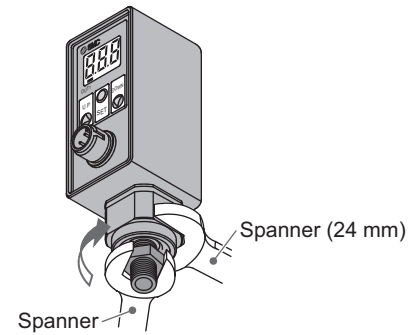

Mounting

- Install using a special bracket (Model: ZS-31-A) available as options.
- Mount the fitting between the bracket assembly and bracket B.
- Then, mount it on the panel precisely by using M6 screws to prevent shrinkage and play.
- Reinforce the mounting by using nuts etc. for the panel with a thickness of 5 mm or less.

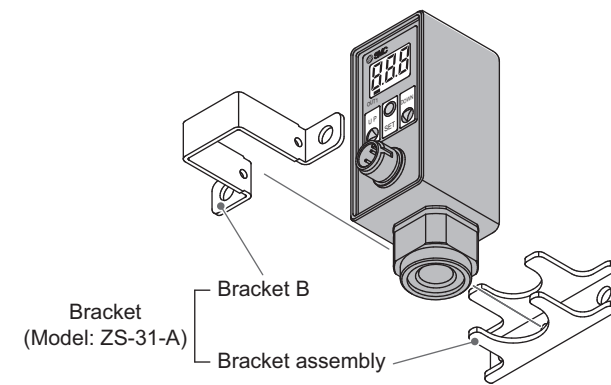

Wiring

- Insert the lead wire with connector with reference to key grooves.
- Pinch the knurl with 2 fingers and tighten it rotating clockwise.

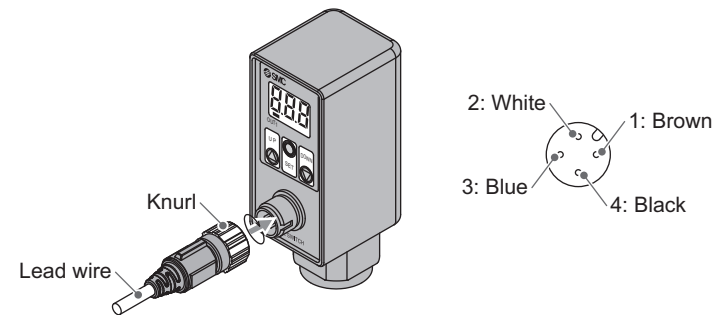

Output -27/-67

1	Brown	DC (+)
2	White	OUT2 (NPN or PNP)
3	Blue	DC (-)
4	Black	OUT1 (NPN or PNP)

Output -65

1	Brown	DC (+)
2	White	NC
3	Blue	DC (-)
4	Black	OUT1 (PNP)

Output -43

1	Brown	DC (+)
2	White	OUT1 (PNP)
3	Blue	DC (-)
4	Black	OUT1 (NPN)

Output -65-X508

1	Brown	DC (+)
2	White	OUT2 (4 to 20 mA)
3	Blue	DC (-)
4	Black	OUT1 (PNP)

Refer to the circuit diagram and the above table for correct wiring.

Installation (continued)

Output Specification

The colors of the wires are shown on the schematic (brown, white, blue, and black) apply to circuits where the SMC lead wire with connector is used.
 The output specifications -27 and -67 have either NPN 2 outputs or PNP 2 outputs. Each output can have an independent pressure set value.
 The output specification -43 has NPN open collector output and PNP open collector output. The NPN output and PNP output can operate with a single pressure setting value. Connect the wire of NPN or PNP output, whichever is necessary. The unnecessary output should remain unconnected.

Internal circuit and wiring

-27
 NPN open collector
 2 outputs
 Max. 30 V, 80 mA,
 Residual voltage 1 V or less

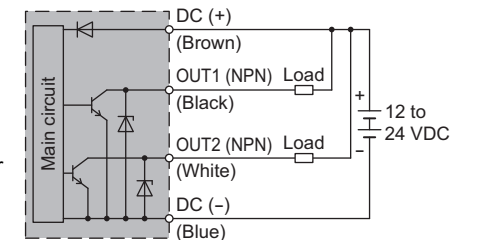

-67
 PNP open collector
 2 outputs
 Max. 80 mA

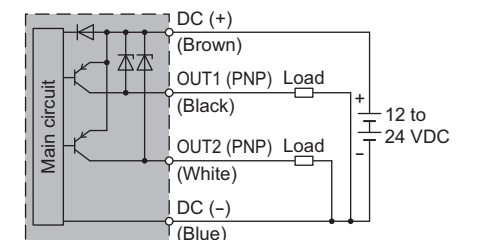

-43
 NPN open collector
 1 output +
 PNP open collector
 1 output
 Max. 30 V (NPN),
 80 mA,
 Residual voltage 1 V or less

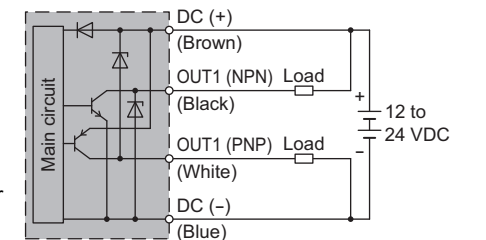

A pressure set value of switch output for NPN and PNP is common.

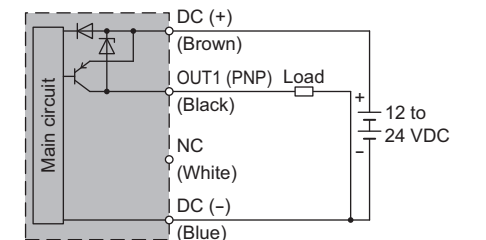

-65
 PNP open collector
 1 output
 Max. 80 mA

-65-X508
 PNP open collector
 1 output
 Max. 80 mA +
 Analog output type
 4 to 20 mA (±2.5%F.S.)
 Max. load impedance:
 300 Ω at 12 V power supply voltage
 600 Ω at 24 V power supply voltage
 Min. load impedance: 50 Ω

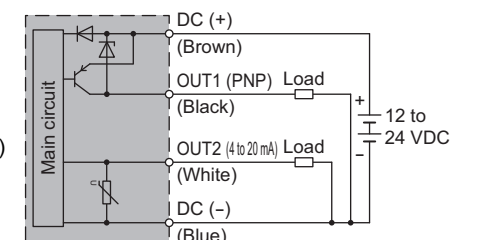

56-ISE7#-TFJ43-F

Settings

■ **Setting Procedures**

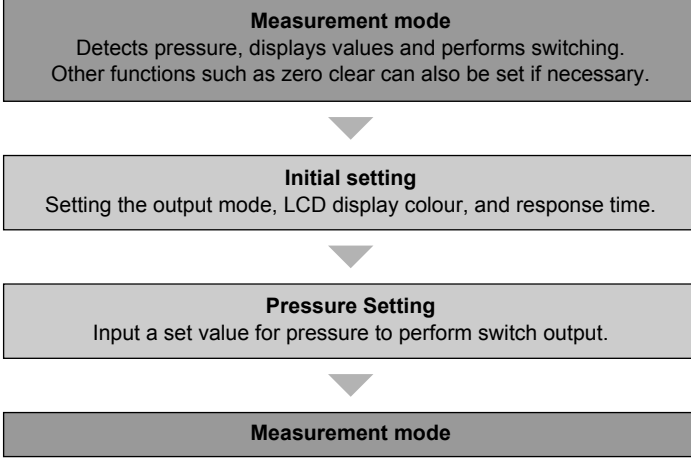

■ **Internal setting**

Press the SET button continuously for 2 seconds or longer. The display shown at the right will appear to allow operating mode of initial setting. Finish initial setting and return to measurement mode by no operation for 30 seconds or keeping pressing the SET button for 2 seconds or longer during initial setting.

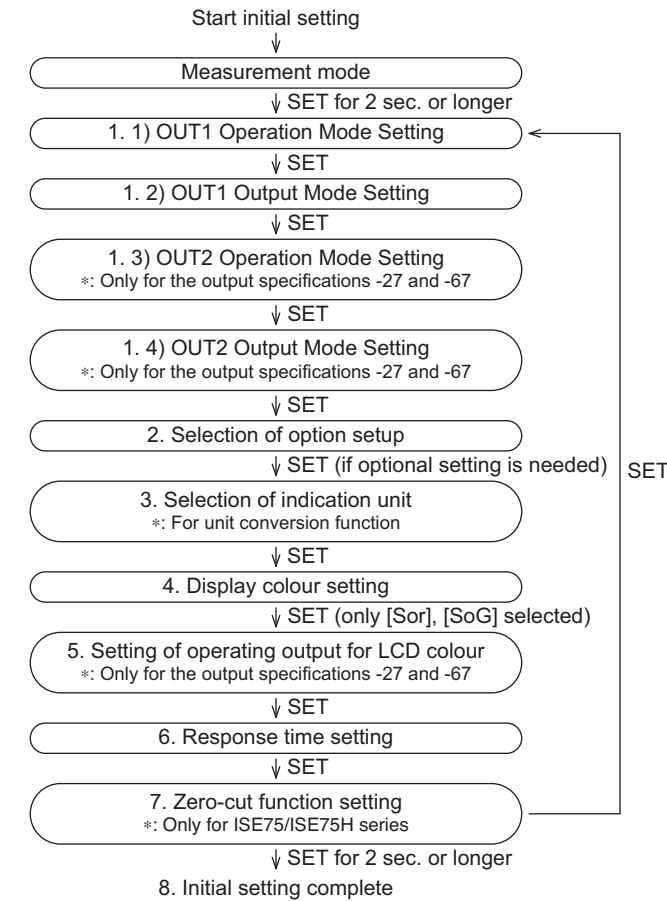
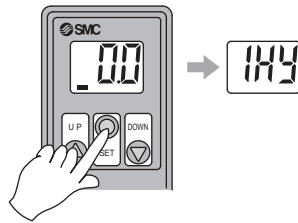

Refer to the operation manual on the SMC website (URL <http://www.smcworld.com>).

Settings (continued)

■ **Pressure setting**

○ **Pressure input mode for OUT1**
Press the SET button in measurement mode to display set values. [P_1] or [n_1] and the current set value will flash in turn. Press the SET button to display the next set value (Hysteresis: H_1). Press the UP or DOWN button to enter the value change mode.

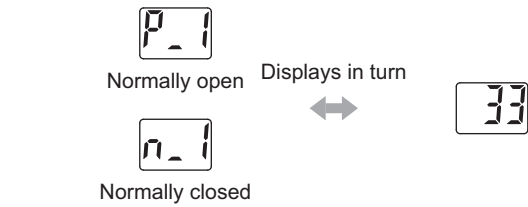

○ **When hysteresis mode is set**
If the hysteresis mode is set, [H_1] and the set value of hysteresis will appear in turn after the setting for [P_1] or [n_1]. Press the SET button to return to normal measurement mode. Press the UP or DOWN button to enter the value change mode.

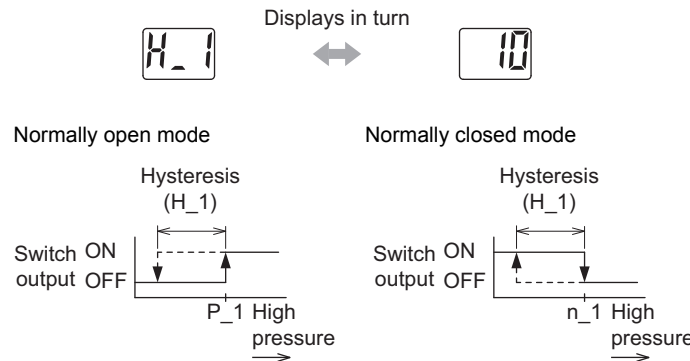

In case hysteresis is set to 2 digits or less, switch output may chatter if input pressure fluctuates near the set value.

○ **When window comparator mode is set**
If the Window comparator mode is set, [P_2] or [n_2] and the current set value will appear in turn after the setting for [P_1] or [n_1]. Press the SET button to display the next set value. (Hysteresis: H_1) Press the UP or DOWN button to enter the value change mode. Next, [H_1] and the set value of hysteresis will appear in turn. Press the SET button to return to measurement mode. Press the UP or DOWN button to enter the value change mode.

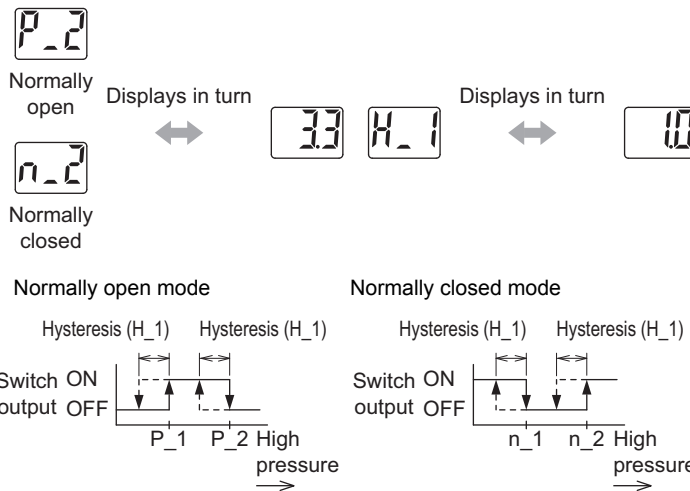

If the initialized value is normally open mode, [P_1] will appear, and [n_1] will appear if it is normally closed mode. The set pressure can be checked without holding or stopping switch output operation.

Settings (continued)

○ **Pressure input mode for OUT2 (for output specifications -27 and -67)**
Set a value for [P_3], [P_4] and [H_2] same as that for OUT1. [P_3], [P_4] ([n_3] or [n_4] for normally closed mode) and [H_2] and the current set values for them flash in turn.

Value Setting
To input a value for pressure setting or other purposes:

1. Press the UP or DOWN button to enter the set value change mode. The first digit will flash. 1st digit
2. Press the UP or DOWN button to set a desired value. 2nd digit
3. Press the SET button to move to the left digit. The 2nd digit will flash. (In the case that the SET button is pressed at the left end digit, the 1st digit will flash.) 3rd digit
4. Press the SET button continuously for 1 second or longer to return to the set values.

Refer to the operation manual on the SMC website (URL <http://www.smcworld.com>).

Other Functions

- **Fine adjustment mode (Fine adjustment function of display value)**
- **Peak and Bottom hold display function**
- **Key lock function**
- **Zero Clear Function**

Refer to the operation manual on the SMC website (URL <http://www.smcworld.com>).

Maintenance

How to reset the product after power cut or forcible de-energizing
The setting of the product will be retained as it was before a power cut or de-energizing. The output condition is also basically recovered to that before a power cut or de-energizing, but may change depending on the operating environment. Therefore, check the safety of the whole system before operating the product. If the system is using accurate control, wait until the pressure sensor has warmed up. (20 to 30 minutes)

Troubleshooting

Refer to the operation manual on the SMC website (URL <http://www.smcworld.com>).

Outline Dimensions

Refer to the operation manual on the SMC website (URL <http://www.smcworld.com>).

Specifications

The pressure switch should be used within the range of specifications. Refer to the operation manual and catalogue for this standard product. If labelled with X: special conditions apply:
Operating ambient temperature range is 0 to 50 °C for ISE70, and -5 to 50 °C for ISE75(H).
Protect the pressure switch from sources of heat which can generate surface temperatures higher than the temperature classification.
Protect the pressure switch, connector and cable against all impact or mechanical damage.
Protect the pressure switch from direct sunlight or UV light using a suitable protective cover.
Do not disconnect the M12 connector before first switching off the power supply.
Use only ATEX approved M12 connectors and use only shielded cable to provide grounding.
Use only a damp cloth to clean the pressure switch body, to avoid an electrostatic charge.
Provide suitable grounding for the pressure switch to avoid electrostatic charging.

Error Indication Function

This function is to display error location and content when a problem or an error occurs.

Error Name	Error Display	Error Type	Troubleshooting Method
Over current Error	OUT1 Er1	A load current of switch output is 80 mA or more.	Turn the power off and remove the output factor for the over current. Then turn the power on.
	OUT2 Er2		
Residual Pressure Error	Er3	During zero clear operation, pressure over ±7%F.S. is applied. After 3 sec., the mode will reset to the measurement mode. ±1 digit of the zero clear range varies with individual product differences.	Perform zero clear operation again after restoring the applied pressure to an atmospheric pressure condition.
Pressurizing Error	HHH	Pressure has exceeded the upper limit of the set pressure range.	Reset applied pressure to a level within the set pressure range.
	LLL	Pressure has exceeded the lower limit of the set pressure range.	
System Error	Er4 Er6 Er7 Er8	Displayed in the case of an internal data error.	Turn the power off and turn it on again.

If the error can not be reset after the above measures are taken, then please contact SMC.

*: Only for the output specifications -27 and -67.

Contacts

AUSTRIA	(43) 2262 62280-0	LATVIA	(371) 781 77 00
BELGIUM	(32) 3 355 1464	LITHUANIA	(370) 5 264 8126
BULGARIA	(359) 2 974 4492	NETHERLANDS	(31) 20 531 8888
CZECH REP.	(420) 541 424 611	NORWAY	(47) 67 12 90 20
DENMARK	(45) 7025 2900	POLAND	(48) 22 211 9600
ESTONIA	(372) 651 0370	PORTUGAL	(351) 21 471 1880
FINLAND	(358) 207 513513	ROMANIA	(40) 21 320 5111
FRANCE	(33) 1 6476 1000	SLOVAKIA	(421) 2 444 56725
GERMANY	(49) 6103 4020	SLOVENIA	(386) 73 885 412
GREECE	(30) 210 271 7265	SPAIN	(34) 945 184 100
HUNGARY	(36) 23 511 390	SWEDEN	(46) 8 603 1200
IRELAND	(353) 1 403 9000	SWITZERLAND	(41) 52 396 3131
ITALY	(39) 02 92711	UNITED KINGDOM	(44) 1908 563888

SMC Corporation

URL <http://www.smcworld.com> (Global) <http://www.smceu.com> (Europe)

Specifications are subject to change without prior notice from the manufacturer. © 2009-2013 SMC Corporation All Rights Reserved.