



Installation and Maintenance Manual Stepper Motor Driver (Pulse input type) Series LECPA

Applicable model number
LECPA***.*



Safety Instructions

This manual contains essential information for the protection of users and others from possible injury and/or equipment damage.

- Read this manual before using the product to ensure correct handling and also read the manuals of related apparatus before use.
- Keep this manual in a safe place for future reference.
- These instructions indicate the level of potential hazard by label of “Caution”, “Warning” or “Danger”, followed by important safety information which must be carefully followed.
- To ensure safety of personnel and equipment the safety instructions in this manual and the product catalogue must be observed, along with other relevant safety practices.

Caution	Indicates a hazard with a low level of risk. Which if not avoided, could result in minor or moderate injury.
Warning	Indicates a hazard with a medium level of risk. Which if not avoided, could result in death or serious injury.
Danger	Indicates a hazard with a high level of risk. Which if not avoided, will result in death or serious injury.

- Electromagnetic compatibility: This product is class A equipment that is intended for use in an industrial environment. There may be potential difficulties in ensuring electromagnetic compatibility in other environments due to conducted as well as radiated disturbances.

Warning

- **Do not disassemble, modify (including change of printed circuit board) or repair the product.**
An injury or product failure may result.
- **Do not operate the product beyond the specification range.**
Fire, malfunction or equipment damage may result.
Use the product only after confirming the specifications.
- **Do not use the product in the presence of flammable, explosive or corrosive gas.**
Fire, explosion or corrosion may result.
This product does not have an explosion proof construction.
- **When using the product as part of an interlocking system:**
Provide a double interlocking system, for example a mechanical system. Check the product regularly to ensure correct operation.
- **Before performing maintenance, be sure of the following:**
Turn off the power supply.

Caution

- **Always perform a system check after maintenance.**
Do not use the product if any error occurs.
Safety cannot be assured if caused by un-intentional malfunction.
- **Provide grounding to ensure correct operation and to improve noise resistance of the product.**
This product should be individually grounded using a short cable.
- **Follow the instructions given below when handling the product.**
Failing to do so may result in product damage.
- **Maintenance space should always be provided around the product.**
- **Do not remove labels from the product.**
- **Do not drop, hit or apply excessive shock to the product.**
- **Unless stated otherwise, follow all specified tightening torques.**
- **Do not bend, apply tensile force, or apply force by placing heavy loads on the cables.**

1 Safety Instructions (continued)

- **Connect wires and cables correctly and do not connect while the power is turned on.**
- **Do not route input/output wires and cables together with power or high-voltage cables.**
- **Check the insulation of wires and cables.**
- **Take appropriate measures against noise, such as noise filters, when the product is incorporated into other equipment or devices.**
- **Take sufficient shielding measures when the product is to be used in the following conditions:**
 - Where noise due to static electricity is generated.
 - Where electro-magnetic field strength is high.
 - Where radioactivity is present.
 - Where power lines are located.
- **Do not use the product in a place where electrical surges are generated.**
- **Use suitable surge protection when a surge generating load such as a solenoid valve is to be directly driven.**
- **Prevent any foreign matter from entering this product.**
- **Do not expose the product to vibration or impact.**
- **Use the product within the specified ambient temperature range.**
- **Do not expose the product to any heat radiation.**
- **Use a precision screwdriver with flat blade to adjust the DIP switch.**
- **Close the cover over the switches before power is turned on.**
- **Do not clean the product with chemicals such as benzene or thinners.**

2 General Instructions

2.1 Wiring

Warning

- **Adjusting, mounting or wiring change should not be done before disconnecting the power supply to the product.**
Electrical shock, malfunction and damage can result.
- **Do not disassemble the cables.**
- **Use only specified cables.**

- **Do not connect or disconnect the wires, cables and connectors when the power is turned on.**

Caution

- **Wire the connector correctly and securely.**
Check the connector for polarity and do not apply any voltage to the terminals other than those specified in the Operation Manual.
- **Take appropriate measures against noise.**
Noise in a signal line may cause malfunction. As a countermeasure separate the high voltage and low voltage cables, and shorten the wiring lengths, etc.
- **Do not route input/output wires and cables together with power or high voltage cables.**
The product can malfunction due to interference of noise and surge voltage from power and high voltage cables to the signal line. Route the wires of the product separately from power or high voltage cables.
- **Take care that actuator movement does not catch cables.**
- **Operate with all wires and cables secured.**
- **Avoid bending cables at sharp angles where they enter the product.**
- **Avoid twisting, folding, rotating or applying an external force to the cable.**
Risk of electric shock, wire breakage, contact failure and loss of control of the product can happen.
- **Fix the motor cables protruding from the actuator in place before use.**
The motor and lock cables are not robotic type cables and can be damaged when moved.
- **The actuator cables connecting the actuator and the driver are robotic type cables. But should not be placed in a flexible moving tube with a radius smaller than the specified value. (Min. 50 mm)**

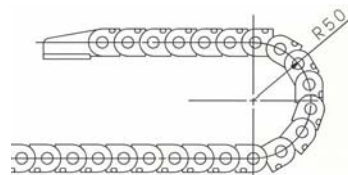

2 General Instructions (continued)

- **Confirm correct insulation of the product.**
Poor insulation of wires, cables, connectors, terminals etc. can cause interference with other circuits. Also there is the possibility that excessive voltage or current may be applied to the product causing damage.

2.2 Transportation

Caution

- **Do not carry or swing the product by the cables.**

2.3 Mounting

Warning

- **Observe the tightening torque for screws.**
Unless stated otherwise, tighten the screws to the recommended torque for mounting the product.
- **Do not make any alterations to this product.**
Alterations made to this product may lead to a loss of durability and damage to the product, which can lead to human injury and damage to other equipment and machinery.
- **When an external guide is used, connect the moving parts of the product and the load in such a way that there is no interference at any point within the stroke.**
Do not scratch or dent the sliding parts of the table or mounting face etc., by striking or holding them with other objects. The components are manufactured to precise tolerances, so that even a slight deformation may cause faulty operation or seizure.
- **Do not use the product until you verify that the equipment can be operated correctly.**
After mounting or repair, connect the power supply to the product and perform appropriate functional inspections to check it is mounted correctly.
- **When attaching to the work piece, do not apply strong impact or large moment.**
If an external force over the allowable moment is applied, it may cause looseness in the guide unit, an increase in sliding resistance or other problems.

- **Maintenance space**

Allow sufficient space for maintenance and inspection.

2.4 Handling

Warning

- **Do not touch the motor while in operation.**
The surface temperature of the motor can increase to approx. 90°C to 100°C due to operating conditions.
Energizing alone may also cause this temperature increase.
As it may cause burns, do not touch the motor when in operation.
- **If abnormal heating, smoking or fire, etc. occurs in the product, immediately turn off the power supply.**
- **Immediately stop operation if abnormal operation noise or vibration occurs.**
If abnormal operation noise or vibration occurs, the product may have been mounted incorrectly. Unless operation of the product is stopped for inspection, the product can be seriously damaged.
- **Never touch the rotating part of the motor or the moving part of the actuator while in operation.**
There is a serious risk of injury.
- **When installing, adjusting, inspecting or performing maintenance on the product, driver and related equipment, be sure to turn off the power supply to each of them. Then, lock it so that no one other than the person working can turn the power on, or implement measures such as a safety plug.**
- **In the case of the actuator that has a servo motor (24VDC), the “motor phase detection step” is done by inputting the servo on signal just after the driver power is turned on.**
The “motor phase detection step” operates the table/rod to the maximum distance of the lead screw. (The motor rotates in the reverse direction if the table hits an obstacle such as the end stop damper.) Take the “motor phase detection step” into consideration for the installation and operation of this actuator

2 General Instructions (continued)

Caution

- **Keep the driver and product combined as delivered for use.**
The product is set in parameters for shipment.
If it is combined with a different product parameter, failure can result.
- **Check the product for the following points before operation.**
 - Damage to electric driving line and signal lines.
 - Looseness of the connector to each power line and signal line.
 - Looseness of the actuator/cylinder and driver mounting.
 - Abnormal operation.
 - Stop function
- **When more than one person is performing work, decide on the procedures, signals, measures and resolution for abnormal conditions before beginning the work.**
- **Also designate a person to supervise the work, other than those performing the work.**
- **An operation test should be performed at low speed, start the test at a predefined speed, after confirming there are no problems.**
- **Actual speed of the product will be changed by the workload.**
Before selecting a product, check the catalogue for the instructions regarding selection and specifications.
- **Do not apply a load, impact or resistance in addition to a transferred load during return to origin.**
In the case of the return to origin by pushing force, additional force will cause displacement of the origin position since it is based on detected motor torque.
- **Do not remove the nameplate.**

2.5 Actuator with lock

Warning

- **Do not use the lock as a safety lock or a control that requires a locking force.**
The lock used for the product with a lock is designed to prevent dropping of work piece.

- **For vertical mounting, use the product with a lock.**

If the product is not equipped with a lock, the product will move and drop the work piece when the power is removed.

- **“Measures against drops” means preventing a work piece from dropping due to its weight when the product operation is stopped and the power supply is turned off.**
- **Do not apply an impact load or strong vibration while the lock is activated.**
If an external impact load or strong vibration is applied to the product, the lock will lose its holding force and damage to the sliding part of the lock or reduced lifetime can result. The same situation will happen when the lock slips due to a force higher than its holding force, as this will accelerate the wear to the lock.
- **Do not apply liquid, oil or grease to the lock or its surroundings.**
When liquid, oil or grease is applied to the sliding part of the lock, its holding force will be reduced significantly.
- **Take “measures against drops” and check that safety is assured before mounting, adjustment and inspection of the product.**
If the lock is released with the product mounted vertically, a work piece can drop due to its weight.

2.6 Please refer to the auto switch references in “Best Pneumatics “ when an auto switch is to be used.

2.7 Unpacking

Caution

- **Check the received product is as ordered.**
If a different product is installed from the one ordered, injury or damage could result.

3 Specifications

Item	Specifications
Compatible motor	Stepper motor (Servo 24VDC)
Driver power supply ^{Note1)}	Rated voltage: 24VDC ±10% Max current consumption: 3A (Peak 5A) ^{Note2)} (For powering the motor drive power, control power, stop and lock release)
Parallel input	5 inputs (photo-coupler isolation) Except pulse signal input terminal and COM terminal.
Parallel output	9 outputs (photo-coupler isolation)
Compatible encoder	A/B phase, Line receiver input Resolution: 800 pulse/rev
Serial communication	Conforming to RS485.
Memory	EEPROM
LED indicator	2 off LED's (green and red)
Lock control	Forced lock-release terminal
Cable length (m)	I/O cable: 1.5m or less (Open collector input) 5m or less (Differential input) Actuator cable: 20m or less
Cooling system	Natural air cooling
Operating temperature range (°C)	0 to 40 (No condensation or freezing)
Operating humidity range (%)	90%RH or less (No condensation or freezing)
Storage temperature range (°C)	-10 to 60 (No condensation or freezing)
Storage humidity range (%)	90%RH or less (No condensation or freezing)
Insulation resistance	Between the housing (radiation fin) and FG 50MΩ (500VDC)
Weight (kg)	0.12 (screw mounting type) 0.14 (DIN rail mounting type)

Note1) Do not use a power supply with "inrush-current control" for the driver power supply.

Note2) The power consumption changes depending on the actuator model. Please refer to the specifications of actuator for more details.

4 Installation (continued)

- **Grounding the driver**
As shown in the diagram, connect the grounding wire with a screw. The driver must be grounded to shield it from electrical noise. The M4 screw, cable with crimping terminal and toothed washer should be obtained separately by the customer.

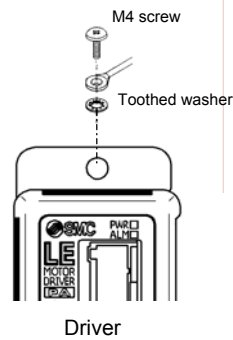

Caution

The product should be connected to a ground. The cross-sectional area of this wire shall be a minimum of 2 mm². The grounding point should be as near to the driver as possible to keep the wire length short.

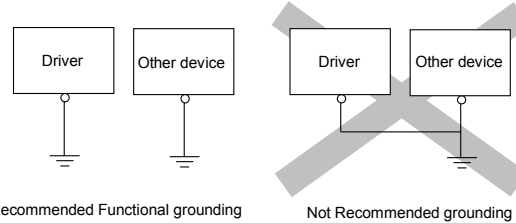

6 Wiring

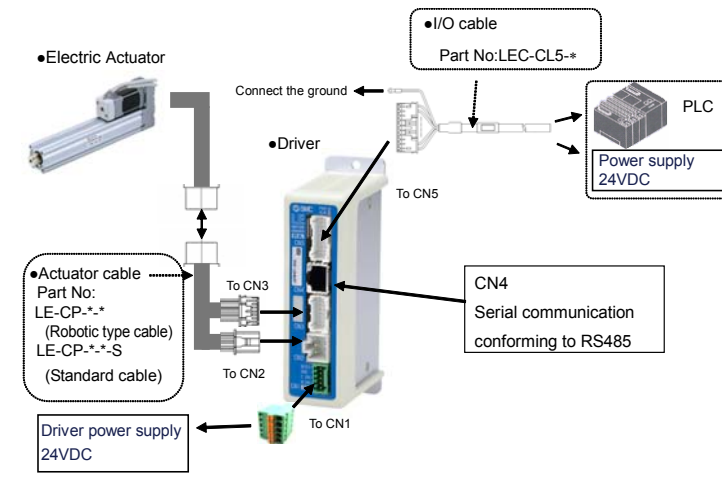

Warning

- **Do not use the stop signal, "EMG" of driver and stop switch on the teaching box as the emergency stop of system.**
The stop signal, "EMG" of driver and the stop switch on the teaching box are for decelerating and stopping the actuator. Design the system with an emergency stop circuit, which complies with safety standards.

6 Wiring (continued)

I/O cable wiring for connection to driver CN5 connector

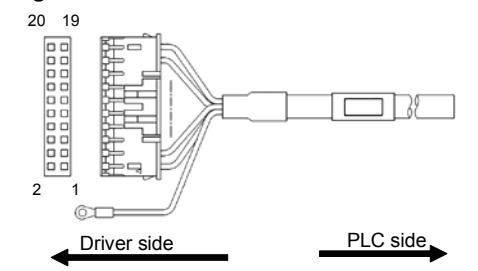

- **Parallel I/O wiring for NPN and PNP connection**

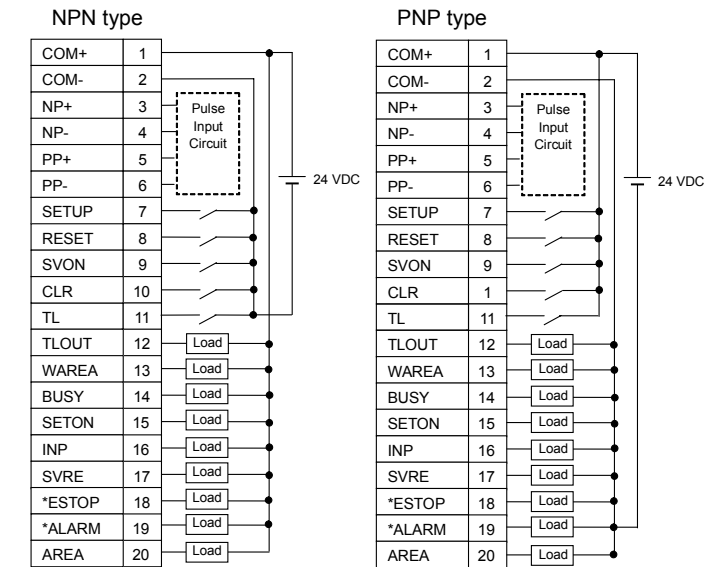

4 Installation

- **How to install**
• Screw mounting type (LECPA***) installation using two M4 screws

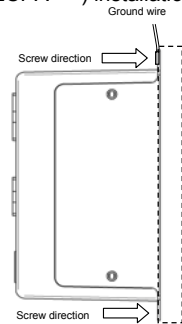

5 Names and Functions of individual parts

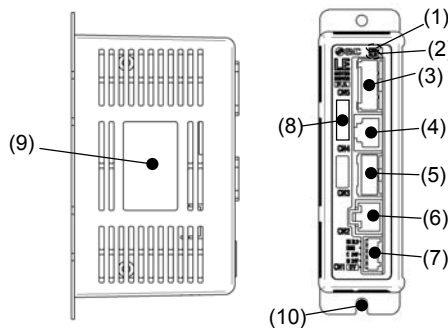

No.	Label	Name	Description
1	PWR	Power LED (green)	Power ON/No alarm: Green light. The green LED flashes while data (step data/parameters) is being written.
2	ALM	Power LED (red)	Power ON/Alarm: Red light.
3	CN5	Parallel I/O Connector (20 pins)	Used to connect PLC, etc. with the I/O cable.
4	CN4	Serial I/O Connector (9 pins)	Used to connect the teaching box, PC, etc.
5	CN3	Encoder connector (16 pins)	
6	CN2	Motor power connector (6 pins)	Used to connect the actuator cable.
7	CN1	Power connector (5 pins)	Used to connect the driver input power supply with the power supply plug: Common power (-), Motor power (+), Control power (+), Stop signal (+), Lock release (+)
8	-	Compatible actuator label	The label indicating the applicable actuator model. It also indicates the type of the parallel I/O (PNP/NPN).
9	-	Product label	The label indicating the part number of the driver.
10	-	FG	Functional ground

Caution

The green LED flashes while the data (step data/parameters) is being written.
Do not turn off the driver input power supply or remove the cable while the data is being written (while the green LED is flashing).
* The data (step data/parameters) may not be written correctly.

Caution

- **Wiring of power supply plug for driver connector CN1**
Connect the positive terminal of the 24 VDC driver power supply to the C24V and M24V terminals of the power supply plug and connect the negative terminal of the 24 VDC driver power supply to the 0V terminal of the power supply plug.
- **For actuators fitted with a lock, fit a lock release switch**
Connect the lock release switch to the supply plug BK RLS terminal.
- **See the power supply plug drawing below for connection details**

Warning

Do not wire the power supply plug incorrectly as this will result in damage to the driver.

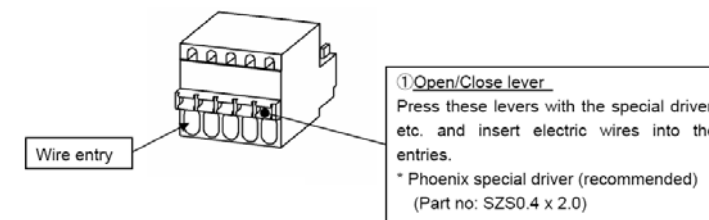

Terminal	Connection description
BK RLS	+ 24V to release the lock
EMG	+ 24V to enable operation
C 24V	+ 24V for the control power
M 24V	+ 24V for the motor power
0v	0V common connection for the: M 24V, C 24V, EMG and BK RLS.

7 Maintenance

- **Perform a maintenance check periodically**
Confirm wiring and screws are not loose.

Warning

- **Do not disassemble or repair the product.**
Fire or electric shock can result.
- **Before modifying or checking the wiring, the voltage should be checked with a tester 5 minutes after the power supply is turned off.**
Electrical shock can result.

- **DIN-rail mounting type (LECPA**D-*) installation onto the DIN rail**

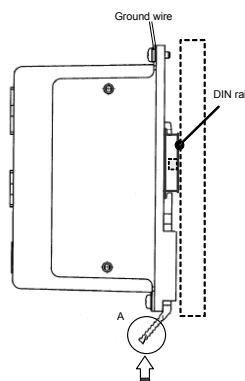

Hook the driver onto the DIN rail and press the lever in the direction of the arrow to lock the driver to the DIN rail.

8 CE Directive

The LE series of actuators and motor drivers conform to the EU EMC directive, if they are installed in accordance with the following instructions.

These components are intended for incorporation into machinery and assemblies forming part of a larger system.

The CE compliance was achieved when the above two components were connected as shown in the diagram below.

Please note that the EMC changes according to the configuration of the customers control panel and the relationship with other electrical equipment and wiring. Therefore conformity to the EMC directive cannot be certified for SMC components incorporated into the customer's equipment under actual operating conditions. As a result it is necessary for the customer to verify conformity to the EMC directive for the machinery and equipment as a whole.

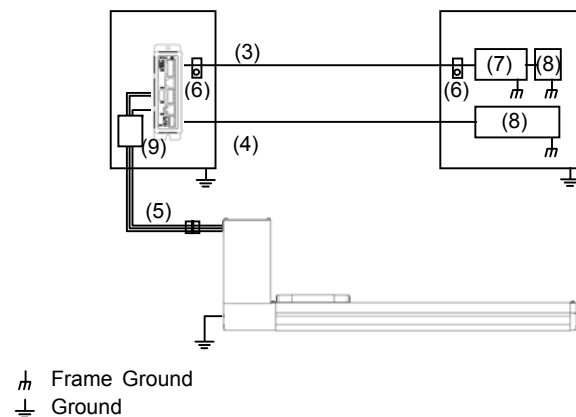

• Machinery parts list

No.	Part name	Part no./Material
1	Motor driver	LECPA Series
2	Actuator	LE Series
3	I/O cable (with shield)	LEC-CL5-□
4	Power supply cable	5 wire with shield (5 m)
5	Actuator cable	LE-CP-□
6	P-clip (for shield ground)	Metal
7	Programmable controller	-
8	Switching power supply	-
9	Noise Filter	LEC-NFA (74271222[WURTH ELEKTRONIK])

The LECPA** driver should be mounted in an IP54 rated metal cabinet for protection from ESD.

The metal cabinet should be grounded with a short grounding cable.

All shielded cables must be grounded inside the cabinet using suitable metal P-Clip or U-Clip as shown.

The shielded cables are:

- 24 VDC Power cable from power supply to LECPA** series driver
- The Input/output cable from driver to PLC

• Grounding the driver

Please refer to the "Installation" section

8 CE Directive (continued)

• P-Clip or U-Clip installation

The function of the P-clip or U-clip is to provide a 360° metallic contact and is a convenient method of ensuring an effective RF ground.

When dealing with EMI issues it is important to know that the DC connection does not maintain the integrity of an AC high frequency connection. High frequency bonding typically involves using wide flat cabling to establish an effective system ground. When applied correctly the P-clip or the U-clip will provide a high frequency connection.

When installing a P-clip or U-clip (see figure below) install the clips as close to the cable ends as possible. In order to provide a suitable ground connection surface, it may be necessary to remove the paint from the panel or the cabinet, an earth stud or a bus bar are also acceptable.

Remove only the outer vinyl jacket of the braided screened cable (this allows the cable braid to connect to the P-clip or U clip). Take care not to damage the braiding. Snap the P-Clip or the U-Clip over the exposed braiding and adjust for a tight fit. Secure the clip to the designated ground with a machine screw and lock washer. The use of a brass or other conductive insert is recommended. Soldering a pigtail to the cable shield is not a suitable method for providing good RF ground.

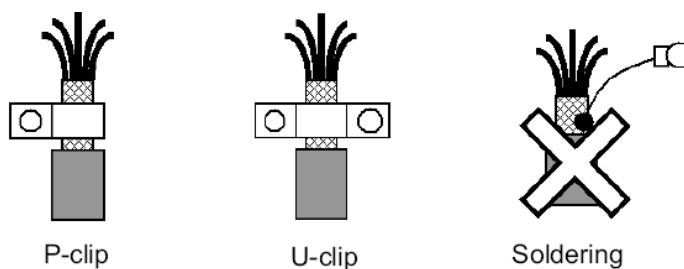

• Grounding the actuator

Please refer to the IMM of the actuator being used, for information on actuator grounding.

⚠ Caution

Note: During installation and maintenance protect the LEC driver from electrostatic discharge (ESD)

Contacts

AUSTRIA	(43) 2262 62280-0	LATVIA	(371) 781 77 00
BELGIUM	(32) 3 355 1464	LITHUANIA	(370) 5 264 8126
BULGARIA	(359) 2 974 4492	NETHERLANDS	(31) 20 531 8888
CZECH REP.	(420) 541 424 611	NORWAY	(47) 67 12 90 20
DENMARK	(45) 7025 2900	POLAND	(48) 22 211 9600
ESTONIA	(372) 651 0370	PORTUGAL	(351) 21 471 1880
FINLAND	(358) 207 513513	ROMANIA	(40) 21 320 5111
FRANCE	(33) 1 6476 1000	SLOVAKIA	(421) 2 444 56725
GERMANY	(49) 6103 4020	SLOVENIA	(386) 73 885 412
GREECE	(30) 210 271 7265	SPAIN	(34) 945 184 100
HUNGARY	(36) 23 511 390	SWEDEN	(46) 8 603 1200
IRELAND	(353) 1 403 9000	SWITZERLAND	(41) 52 396 3131
ITALY	(39) 02 92711	UNITED KINGDOM	(44) 1908 563888

SMC Corporation

URL : [http:// www.smcworld.com](http://www.smcworld.com) (Global) <http:// www.smceu.com> (Europe)

Specifications are subject to change without prior notice from the manufacturer.

© 2009 SMC Corporation All Rights Reserved.