



## Installation and Maintenance Manual

### Electric Cylinder

#### Series LZB

#### 1. Safety Instruction

These instructions indicate the level of potential hazard by labels of "Warning" and "Caution". To ensure safety, be sure to observe ISO 10218 /JIS B8433 and other safety practices.

	<b>WARNING:</b>	Operator error could result in serious injury or loss of life.
	<b>CAUTION:</b>	Operator error could result in injury or equipment damage.

#### 1.1 Symbols

Symbol	Explanation
	Symbol meaning warning and caution. Contents are instructed by figure or phrase in the symbol.
	Symbol meaning do not operate are instructed by figure or phrase in the symbol.
	Symbol meaning operate are instructed by figure or phrase in the symbol.

#### 1.2 Operator

- This manual is for the person in charge of assembly, operation, and maintaining of machinery and device with electric control equipment who has enough knowledge and experience.
- The manual must be read through before assembly, operation and maintenance.

#### 1.3 Application limitation

\* This product aims at application for common factory automation equipment. Do not use LZB for machinery and device (\*1) that directly concern human life or those which malfunction or failure could cause serious damage.

\*1: Machinery and device that directly concern human life are;

- Life support system or medical equipment
- Device obligated by laws and regulation such as fire protection law and the building code.
- Equipment and devices which comply with above.

\* Contact SMC Sales office before use on any of the following relating to human safety and that have an impact on public utilities(\*2). Special consideration(\*3) is necessary for the management, maintenance and control of the system.

\*2: Systems relating to human safety that have impact on the public utilities are;

- Main machine control and nuclear plant control systems, safety protection systems, system of nuclear installation, and other systems important for safety.
- Drive control and flight control systems of public transport systems.
- Equipment and devices in contact with food and beverage.

\*3: Special consideration means to discuss with SMC engineers, and to construct a safe system (The foolproof design, the fail safe design, and design using redundancy circuits).

\* Special consideration for safety and security to prevent the risk of damage by failure and malfunction caused by the occurrence of environmental stress (change over time).

<b>WARNING</b>	
	- Do not overhaul or modify parts (incl. circuit board). It might cause injury or failure.
	- Do not operate or set with wet hand. It might cause electric shock.
	- Do not exceed specified operating range. It might cause fire accident, malfunction and cylinder breakage. - Keep within operating range.
	- Do not use in areas containing flammable gas, explosive gas or corrosive gas. It may cause fire, explosion and corrosion. This actuator is not of an explosion proof structure.
	- Do not connect or operate with non-applicable motor, cylinder. It might cause fire, explosion and corrosion.
	- Do not touch the work while the cylinder is operating. It might cause injury.
	- To avoid the risk of damage due to failure and malfunction occurring, establish back-up system such as multiple system equipment/device, fail-safe structure in advance.

<b>CAUTION</b>	
	- The heat sink of the directional control equipment and the cylinder motor become hot during operation. Do not touch until they have cooled down.
	- Ground FG terminal Without proper ground, malfunction may occur which could lead to an accident. For better ground efficiency, keep the ground wiring distance short and separate grounding is recommended.
	- Inspect correct function after maintenance. Stop operation when device and equipment does not work correctly. Unexpected malfunction might risk safety of operation. Perform emergency stop and ensure safety.
	- Connect the power and turn on the switch after ensuring the safety of the slider's moving range. Moving slider might cause an accident.

#### 1.4 Caution on operation

Design your application using the recommendations shown below.

- Design recommendations
- Please read this manual and design accordingly.

#### 1.5 Specification

- Keep within specified voltage.
- Do not apply a workload that exceeds the max. load capacity.
- Keep maintenance space.

#### 1.6 Handling

##### Mounting

- Do not drop, bump or apply excessive impact.
- Keep directional control equipment 50 mm or more away from inner surface of control box or other equipment.
- Hold by the body of the cylinder when handling.
- Keep specified tightening torque.
- Do not mount the cylinder where it can be trod on.
- Cylinder should be mounted on a flat surface with machine accuracy or equivalent accuracy.
- When using mounting feet, always use two.
- When mounting the work to the rod end, clamp across flats on the rod end for tightening so as not to apply a rotating force to the end.

##### 1.7 Wiring

- Avoid repeatedly bending or stretching the cable.
- Confirm proper wiring.
- Do not wire while power applied.
- Do not wire adjacent to power lines or high voltage lines to avoid noise interference.
- Confirm proper insulation of wiring.

##### 1.8 Operating environment

- Avoid use in the following environments.
- Location with a lot of debris, dust, water, chemicals, or oil.
- Location where magnetic field is generated.
- Location where temperature cycles are applied.
- Location where surge voltages are generated.
- Use surge absorption element built-in type when directly operating surge voltage generating load such as the relay and solenoid valve.
- Prepare lightning surge protection on the device.
- Mount where no vibration or impact exists.

##### 1.9 Maintenance

- Periodic maintenance is required.

#### 2. Part check

Ensure parts below are included in the package.

Parts	Qty.
Main body	1
Operation Manual	1

Accessories	L[ZBB]	L[ZBF]	L[ZBL]	L[ZBU]
Rod mount nut	1pc.	1pc.	1pc.	1pc.
End mount nut			1pc.	
Male thread mount nut (*)	1pc.	1pc.	1pc.	1pc.
Flange		1pc.		
Rod end mounting foot			1pc.	
Housing end mounting foot			1pc.	
Trunnion				1pc.

\*Included only for male thread type (L[ZB]000-000A[L])

#### 3. Parts description

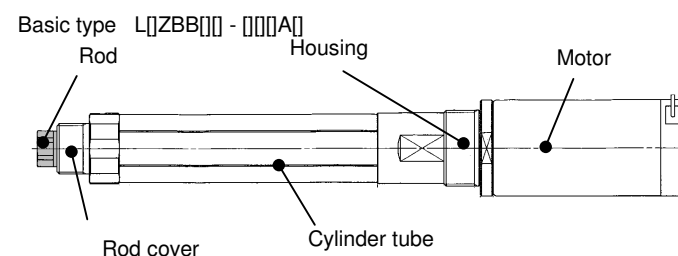

Flange type L[ZBF]00-000A[]

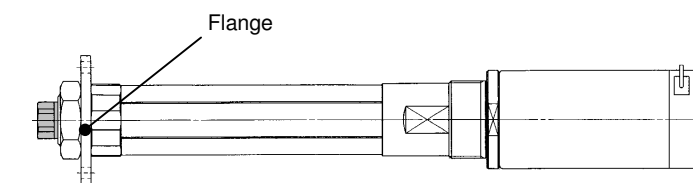

Foot type L[ZBL]00-000A[]

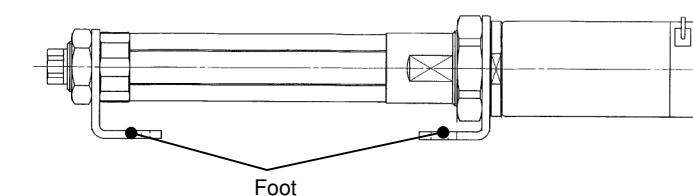

Trunnion type L[ZBU]L-000A[]

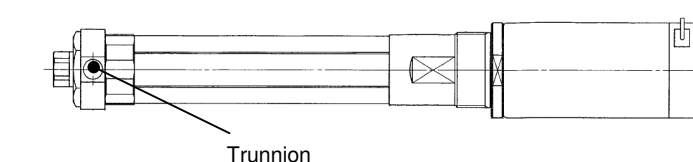

#### 4. Mounting

##### 4.1 Direct mounting on the rod cover

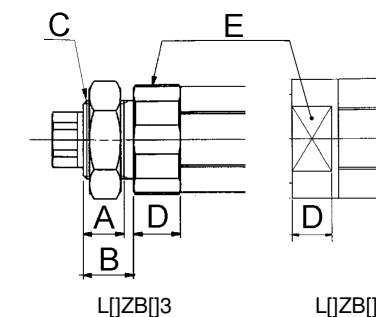

Refer drawing above for L[ZB]3 and L[ZB]5 rod cover.

Model no.	A	B	D	E
L[ZB]3	10.5	13	12	Hex. across flat 27
L[ZB]5	17	20	14.5	Across flat 36

Model no.	C	[Tightening torque]
L[ZB]3	M20X1.5	[13~15 N·m]
L[ZB]5	M32X2	[20~22 N·m]

\* Use an adhesive for the nut fixing.

4.2 Direct mounting on the motor

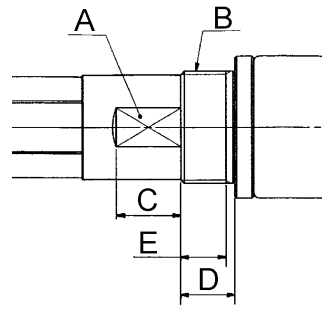

Model no.	A	C	D	E
L[ZB]3	Spanner flat 26	19	15	12.5
L[ZB]5	Spanner flat 38	17.5	14	11

Model no.	B	[Tightening torque]
L[ZB]3	M30 x 1.5	[18~20 N*m]
L[ZB]5	M45 x 1.5	[24~26 N*m]

\*Use locking mechanism when mounting

**CAUTION**

**DO NOT**

Do not install the cylinder only by mounting it to the motor

4.3 Mounting flange

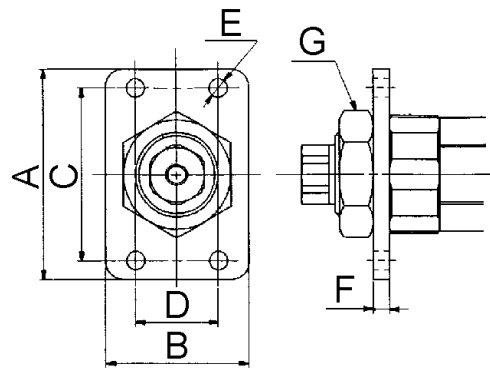

Model no.	A	B	C	D	E
L[ZB]3	50	34	41	20	4-φ4.5
L[ZB]5	82	52	66	36	4-φ7

Model no.	F	G
L[ZB]3	4	Across flat 26
L[ZB]5	5	Across flat 41

< L[ZBL3] > Recommended set screw : M4 4pcs.

< L[ZBL5] > Recommended set screw : M6 4pcs.

4.4 Mounting foot

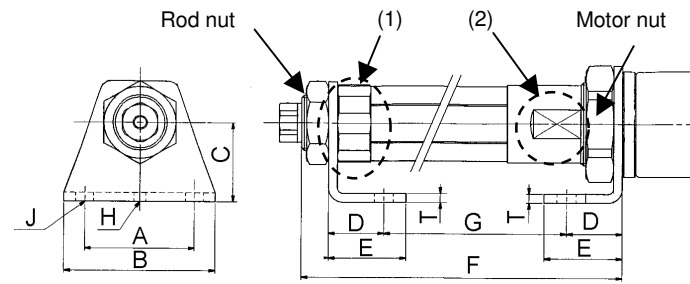

\*Use (1) (across flat) when fixing the foot at the rod.  
Tightening torque L[ZB]3: 13 - 15 N\*m / L[ZB]5: 20 - 22 N\*m

\*Use 2 spanner flats when fixing the foot to the motor.  
Tightening torque L[ZB]3: 18 - 20 N\*m / L[ZB]5: 24 - 26 N\*m

Model no.	A	B	C	D	E	T
L[ZB]3	40	55	28.5	20	28	3.2
L[ZB]5	55	75	38	23	33	3.2

Model no.	F	G	H	J
L[ZB]3	121.5+st	71.7+st	φ4	φ6.8
L[ZB]5	151.5+st	88.7+st	φ4	φ7

Recommended set screw: M6 4pcs. φ4 Knock pin 2pcs.

4.5 Mounting trunnion

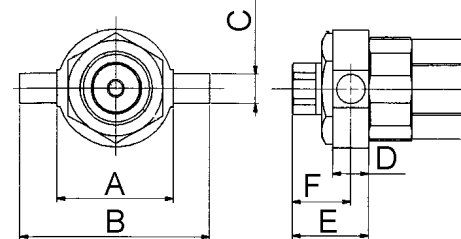

Trunnion mounting torque  
L[ZB]3L: 13 - 15 N\*m / L[ZB]5L: 20 - 22 N\*m

Model no.	A	B	C	D	E	F
L[ZB]3	32	52	φ8e9 -0.025 -0.061	10	21	16
L[ZB]5	53	77	φ10e9 -0.025 -0.061	11	32	26.5

**CAUTION**

**DO**

Mount the trunnion pin and the shaded part of the tube as in drawing below.  
**Incorrect mounting could lead to failure.**

4.6 Mounting to workpiece

Female thread type

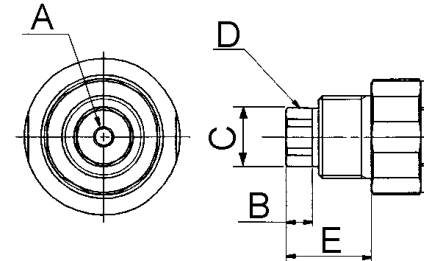

Model no.	B	C	D	E
L[ZB]3	6.5	φ14	Across flat 13	21
L[ZB]5	10	φ22	Across flat 21	32

Model no.	A	[Tightening torque]
L[ZB]3	M6 x 1.0 x 8 deep	[5.2 N*m]
L[ZB]5	M10 x 1.25 x 12 deep	[24.5 N*m]

Male thread type

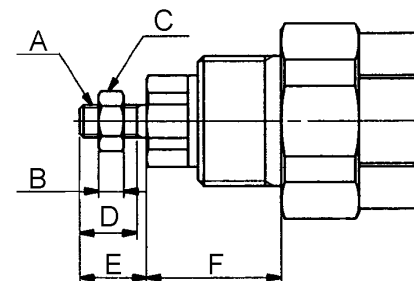

Model no.	B	C	D	E	F
L[ZB]3	5	Across flat 10	10	12	21
L[ZB]5	6	Across flat 17	19.5	22	32

Model no.	A	[Tightening torque]
L[ZB]3	M6 x 1.0	[5.2 N*m]
L[ZB]5	M10 x 1.25	[24.5 N*m]

**CAUTION**

**DO**

When mounting the work to the rod end, clamp the end across flat for tightening, so as not to apply rotating force to the rod.

4.7. Mounting auto switch

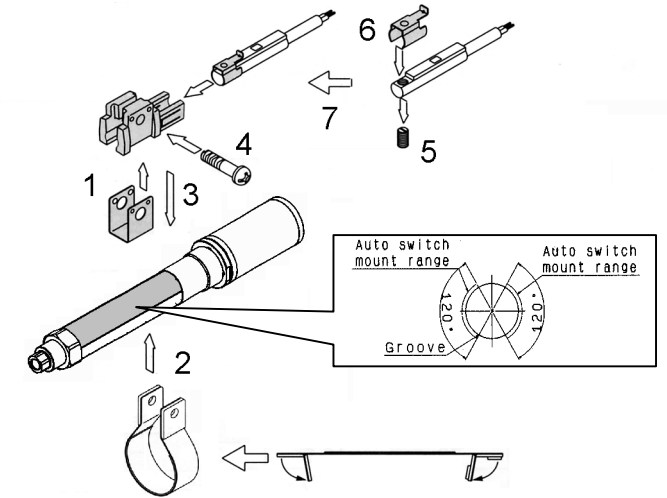

1. Install the switch bracket to the switch holder.
2. Mount the switch band to the cylinder tube.
3. Install the switch holder between reinforcement boards of the switch-mounting band. The Switch should be set within the Auto switch mounting range.
4. Fix the switch mounting screw through the switch mounting band and the switch holder and pre-tighten for before final tightening after adjusting switch position.
5. Remove the setscrew included with the Auto switch.
6. Attach the switch spacer to the Auto switch.
7. Insert the auto switch with the switch spacer attached from the behind of the switch holder, and tightens with specified torque (0.8 N\*m - 1.0 N\*m).

4.8 Switch position adjustment

1. Unscrew the switch set screw for three turns to adjust the switch set position.
2. Tighten screws after adjustment.

4.9 Switch removals

1. Unscrew out the switch set screws from the switch holder.
2. Return the switch to the position where it stops at lead wire side.
3. Lift the joint of the switch lead wire upward to approx. 45 degree.
4. Pull out the switch diagonally backwards.

5. Wiring

Connect the motor cable to the specified directional control equipment LC3F2 motor output terminal (CN3).  
(See "Directional Control Equipment LC3F2 Operation Manual" for details)

CN3 Motor output terminal

Pin No.	Terminal	Function
1	OUT A	Motor output A (Blue line)
2	OUT B	Motor output B (Red line)

Housing : VHR-2N (JST) Contact : BVH-21T-P1.1 (JST)  
\*Protection ground terminal connection  
Ground the system using the protection ground terminal on the electric cylinder motor.

L[ZB]3: M3 x 0.5 x 3 deep  
L[ZB]5: M4 x 0.7 x 3 deep

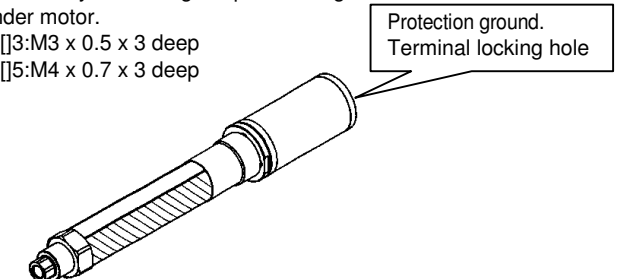

## 6. Test run

### Procedure of adjustment and test run

Perform adjustment and test run after checking the installation and wiring.

#### (1) Supply power

Indicator lamp (POWER) turns on when applying power to directional control equipment.

#### (2) Test run

Initiating a signal to the control terminal and the actuator starts. Actuator may have sudden movement if operated with max. torque. Set the dial at minimum (counter-clockwise), and increase the torque gradually.

Terminal	A-PHASE direction	B-PHASE direction	Stop command
ON	ON	ON	OFF
SET	ON	ON	-
A-PHASE	ON	OFF	-

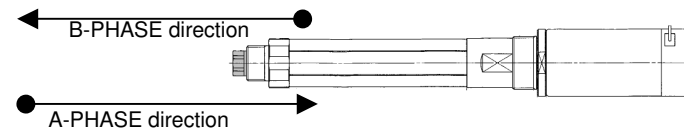

**WARNING**

Do not touch the work during test run and torque adjustment.

## 7. Check / Maintenance

### 7.1 Daily check

Perform inspection before/after operation

Check item	What to check
Appearance	No gouge or nick found on the body. No debris, dust or water adhered.
Motor	If it is too hot.
Cable	No damage, cracked or incorrect wiring

### 7.2 Periodic check

Inspection every 6 months or the not use for 1 month or longer.

Inspection item	What to inspect
Mounting the body	No loose part.
Feeding screw sliding part	Rod is not obstructed in operation in allowable moving range.

### 7.3 Life

Reference for energizing time

Model no.	Mount direction	Energizing time
L[Z]3	Horizontal	Approx.3 000hrs. (Operation 60%, Holding 40%)
L[Z]5		Approx.4 000hrs. (Operation 60%, Holding 40%)

Reference of travel depending lead

Model no.	Mount direction	Travel ( km )
L[Z]3 L	Horizontal	200
L[Z]3M		640
L[Z]3H		1 200
L[Z]5L		280
L[Z]5M		850
L[Z]5H		1 700

**Note.** Refer shorter data from above.

Reference above is calculated based on the actual life test. Therefore, the life may be shorter due to the environment or operating conditions.

## 8. Troubleshooting

Refer to the troubleshooting section of "Operation Manual of Directional Control equipment LC3F2 " when cylinder (motor) does not start or operation stops suddenly.

## 9. How to Order

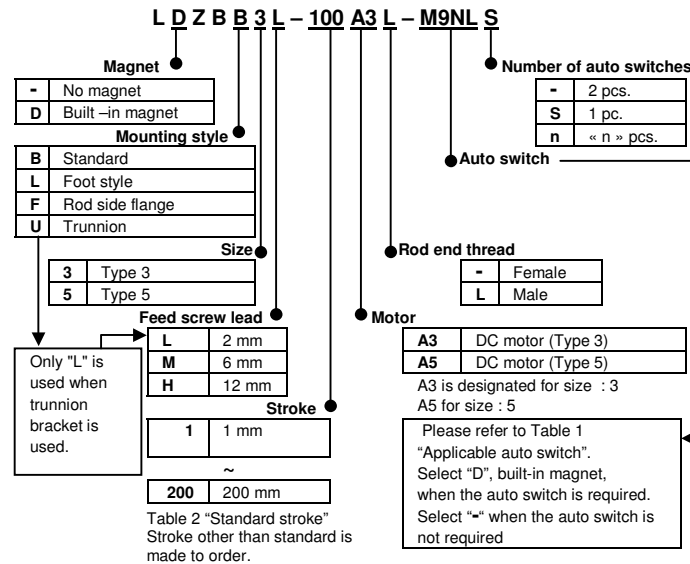

**Table 1 Applicable auto switch**

Auto switch model	Lead wire length symbols (m)		Wire (Output)	Indicator light
	0.5 (Nil)	3 (L)		
D-M9N	•	•	3 wire (NPN)	Yes
D-M9P	•	•	3 wire (PNP)	
D-M9B	•	•	2 wire	

**Table 2 Standard stroke (mm)**

Model	25	40	50	100	200
LZB3					
LZB5					

## 10. Specification

	L[Z]3L- A3	L[Z]3M- A3	L[Z]3H- A3
Mount direction	Horizontal		
Feed screw lead(mm)	2	6	12
Speed with no load (mm/s)	33 or more	100 or more	200 or more
Rated thrust (N)	80 or more	43 or more	24 or more
Stroke range (mm)	1 - 200 (Std. stroke: 25/40/50/100/200)		
Applicable directional control equipment model	LC3F212-5A3[]		
Applicable Auto switch	D-M9[]		
Auto switch mount band	BM2-025		
Auto switch mount bracket	BJ3-1		

	L[Z]5L- A5	L[Z]5M- A5	L[Z]5H- A5
Mount direction	Horizontal		
Feed screw lead (mm)	2	6	12
Speed with no load (mm/s)	33 or more	100 or more	200 or more
Rated thrust (N)	196 or more	117 or more	72 or more
Stroke range (mm)	1 - 200 (Std. stroke: 25/40/50/100/200)		
Applicable directional control equipment model	LC3F212-5A5[]		
Applicable Auto switch	D-M9[]		
Auto switch mount band	L1ZB45-0318		
Auto switch mount bracket	BJ3-1		

## 11. Regarding EMC Directive

The EMC directive is applied to the DC motor fitted to the electric cylinder LZ series and the directional control equipment as a combination.

Please refer to the manual of the directional control equipment for the test condition at the third party.

### How to use the protection ground terminal:

For the emission noise reduction, ground to the protection ground terminal on the end of motor, using a metal P-clip on to the shielded part of the motor output terminal cable.

(At the directional control equipment end of the motor output terminal cable attach to the frame ground.)

- The P-clip and the motor output terminal cable to be supplied by the customer.
- If required SMC can also supply the motor output terminal cable by the ordering code as shown below.

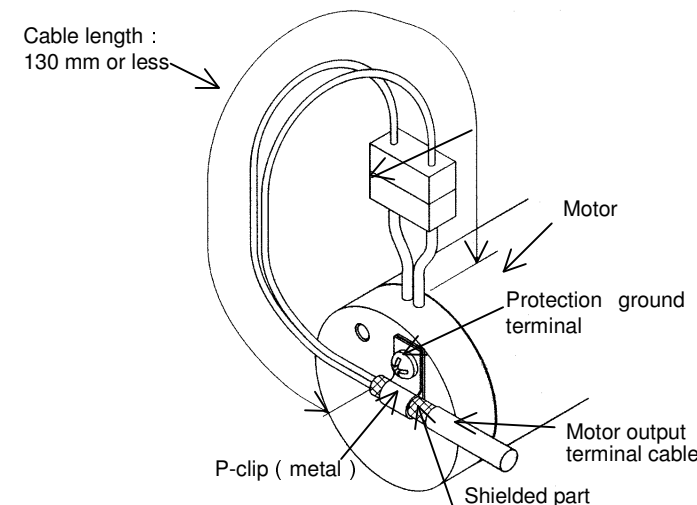

Motor output terminal cable :  
LC3F2-1-C3-02-1  
Cable length 0.2 : 2 m  
0.5 : 5 m

## 12. European Contact List

### 12.1 SMC Corporation

Country	Telephone	Country	Telephone
Austria	(43) 2262 62 280	Italy	(39) 02 92711
Belgium	(32) 3 355 1464	Netherlands	(31) 20 531 8888
Czech Republic	(420) 5 414 24611	Norway	(47) 67 12 90 20
Denmark	(45) 70 25 29 00	Poland	(48) 22 548 50 85
Finland	(358) 207 513 513	Portugal	(351) 2 610 89 22
France	(33) 1 64 76 1000	Spain	(34) 945 18 4100
Germany	(49) 6103 4020	Sweden	(46) 8 603 0700
Greece	(30) 1 342 6076	Switzerland	(41) 52 396 3131
Hungary	(36) 1 371 1343	Turkey	(90) 212 221 1512
Ireland	(353) 1 403 9000	United Kingdom	(44) 800 138 2930

### 12.2 Websites

SMC Corporation	www.smcworld.com
SMC Europe	www.smceu.com