



Installation and Maintenance Manual

VX31/32/33, 3 Port Solenoid Valves and VVX31/32/33, Manifold Series

For future reference, please keep this manual in a safe place

This manual should be read in conjunction with the current catalogue

Safety Instructions

These safety instructions are intended to prevent a hazardous situation and/or equipment damage. These instructions indicate the level of potential hazard by label of "Caution", "Warning" or "Danger". To ensure safety, be sure to observe ISO4414 (Note1), JIS B 8370 (Note2) and other safety practices.

Note 1: ISO 4414: Pneumatic fluid power – Recommendations for the application of equipment to transmission and control systems.
Note 2: JIS B 8370: Pneumatic system axiom.

CAUTION : Operator error could result in injury or equipment damage.

WARNING: Operator error could result in serious injury or loss of life.

DANGER : In extreme conditions, there is a possible result of serious injury or loss of life.

WARNING

1. The compatibility of pneumatic equipment is the responsibility of the person who designs the pneumatic system or decides its specifications.

Since the products specified here are used in various operating conditions, their compatibility for the specific pneumatic system must be based on specifications or after analysis and/or tests to meet your specific requirements.

2. Only trained personnel should operate pneumatically operated machinery and equipment.

Compressed air can be dangerous if an operator is unfamiliar with it. Assembly, handling or repair of pneumatic systems should be performed by trained and experienced operators.

3. Do not service machinery/equipment or attempt to remove component until safety is confirmed.

- 1) Inspection and maintenance of machinery/equipment should only be performed after confirmation of safe locked-out control positions.
- 2) When equipment is to be removed, confirm the safety process as mentioned above. Switch off air and electrical supplies and exhaust all residual compressed air in the system.
- 3) Before machinery/equipment is re-started, ensure all safety measures to prevent sudden movement of cylinders etc. (Bleed air into the system gradually to create back-pressure, i.e. incorporate a soft-start valve).

4. Contact SMC if the product is to be used in any of the following conditions:

- 1) Conditions and environments beyond the given specifications, or if product is used outdoors.
- 2) Installations in conjunction with atomic energy, railway, air navigation, vehicles, medical equipment, food and beverage, recreation equipment, emergency stop circuits, press applications, or safety equipment.
- 3) An application which has the possibility of having negative effects on people, property, or animals, requiring special safety analysis.

CAUTION

Ensure that the air supply system is filtered to 5 micron.

Energise to open type (N.C.) (Fig 1)

Port size	Orifice size (mm)	Flow rate		Model	Max. operating pressure differential MPa (kgf/cm ²)		Max system pressure MPa (kgf/cm ²)	Weight (g) (Note)
		Cv	Effective area mm ²		NO, NC	CO		
1/8 (6A)	1.5	0.08	1.4	VX311 -01	1.0(10)	0.6(6)	Water Air Oil: 2.0(20) Steam: 1.0(10)	330
	2.2	0.16	2.8	VX312 -01	0.5(5)	0.3(3)		
	3	0.24	4.3	VX313 -01	0.3(3)	0.2(2)		
1/4 (8A)	1.5	0.08	1.4	VX311 -02	1.0(10)	0.6(6)		
		0.16	2.8	VX312 -02	0.5(5)	0.3(3)		
	2.2	0.19	3.4	VX3224-02	-	0.6(6)		
		0.24	4.3	VX3324-02	-	1.0(10)		
	3	0.33	6	VX3234-02	-	0.3(3)		
		0.33	6	VX3334-02	-	0.6(6)		
3/8 (10A)	2.2	0.19	3.4	VX3224-03	-	0.6(6)		
		0.24	4.3	VX3324-03	-	1.0(10)		
	3	0.33	6	VX3234-03	-	0.3(3)		
		0.33	6	VX3334-03	-	0.6(6)		
	4	0.5	9	VX3244-03	-	0.15(1.5)		
		0.5	9	VX3344-03	-	0.3(3)		

Note: It is a grommet value. Add the conduit 10g, the DIN connector 30g and the terminal 60g respectively.

Installation

WARNING

Ensure all air and power supplies are ISOLATED before commencing installation.

Do not install these valves in explosive atmospheres.

If these valves are exposed to water or oil droplets, ensure that they are protected.

If it is intended to energise a valve for an extended period, please consult SMC.

If air leakage causes associated equipment to malfunction cease using valve and inspect for cause.

Check fixings while pressure and power are applied. Initial function and leakage tests should be performed after installation.

Install only once safety instructions have been read and understood.

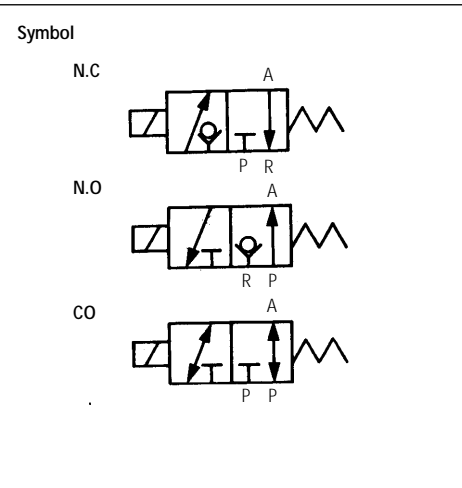

Fig 1

Construction and parts (Fig 2)

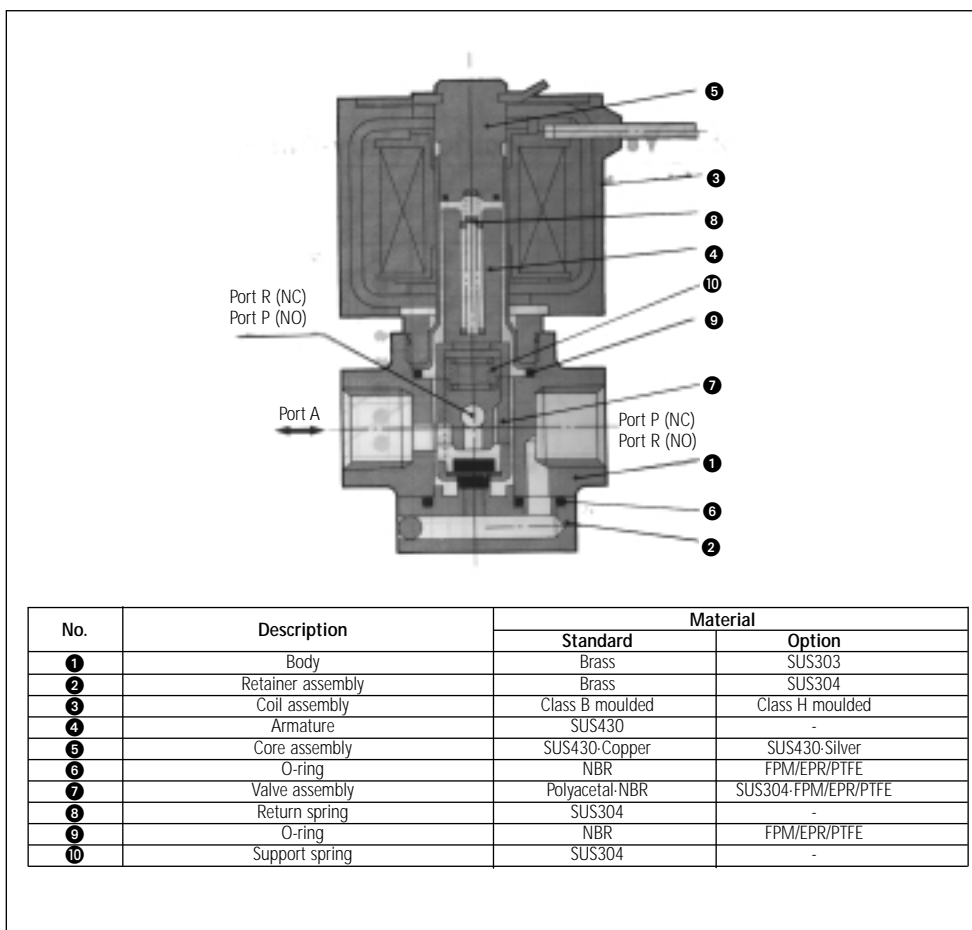

Fig 2

Manifold (Fig 3)

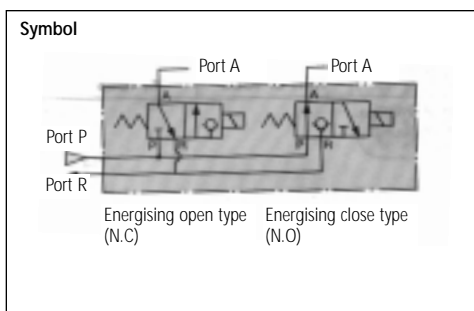

Fig 3

Manifold specifications

Manifold type	B Mount
Manifold base type	Common pressure, Common exhaust, Individual out
Number of valves	2-10 stations
Blanking plate (with gasket, O-rings)	VVX31--VX011-004, VVX32/33--VX011-005

Electrical connection

CAUTION

Isolate both power and air supplies before removing/replacing connector.

In the case of DIN connector and terminal block, connections are shown in Fig 4.

1. Loosen the top screw and remove the connector housing from the terminal spades on the solenoid.
2. Remove the housing screw and insert a screwdriver into the slot on the underside of the DIN cap and carefully remove the block.
3. Loosen the terminal screws on the block and insert the stripped leads. Secure each lead by re-tightening the appropriate terminal screw.
4. Tighten the housing grommet nut to secure the cable.

With DIN connector

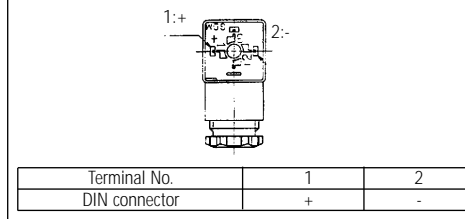

Fig 4

CAUTION

Pull connector out vertically, never at an angle.

In the case of the conduit entry, the connections are shown below.

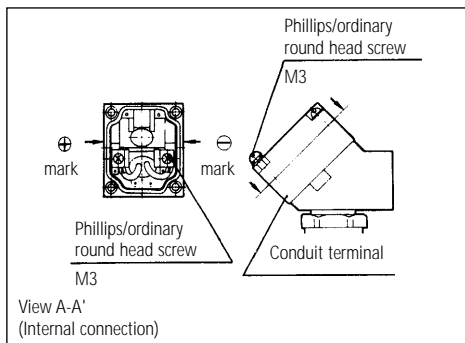

Fig 5

Wiring

Should the coil be subjected to a surge voltage, place a surge suppresser in parallel with the coil if not fitted as an option. The allowable voltage range is -10% - +10% of rated voltage. The voltage found across the coil, when de-energised is :
AC: 20% or less of rated voltage
DC: 2% or less of rated voltage

Piping

- 1 Piping should be thoroughly flushed to remove sludge, cutting oil and dust.
- 2 During piping and coupling connection, care should be taken to prevent contamination by dirty threads or sealing materials. When applying sealing tape to threads, the thread should extend one screw pitch beyond the tape.
- 3 Pay attention to the direction of piping (solenoid valve IN, OUT.) In the case of 2 port valves, [IN] indicates the inlet side. In the case of 3 port valves, [P] indicates inlet, [A] indicates outlet, [R] indicates exhaust.
- 4 The coil should not be subjected to an external force. When tightening, apply a wrench to the outside of the pipe mounting area only.
- 5 In the case of solenoid valves specified for vacuum and non-leak use, please pay special attention to the exclusion of foreign matter and leakage through the couplings.
- 6 In the process of piping, if the coil assembly needs to be removed, do so by removing its retainer. After completion of piping please reattach the retainer.
- 7 The piping system should not be grounded. Grounding would cause electrolytic corrosion.
- 8 To prevent collection of fluid within the piping circuit please install a relief valve within the circuit.

Mounting (Fig 6)

- 1 The solenoid valve may be mounted in any orientation. However when mounted upside down, foreign material in the fluid is liable to adhere to the iron core. This mounting position is not recommended by SMC.
- 2 Do not keep coil assemblies warm with insulating materials etc. It will cause the coil to burn out. Anti-freezing tape, heater etc. should be applied to piping and body areas only.
- 3 Except in the case of steel pipes and couplings, mount the valve with a bracket, especially in the case of non-leak and vacuum valves. The bracket will help prevent loosening of the couplings.
- 4 Do not place the valve in areas of severe vibration.

In the case of manifold mounted type valves (where 00 connection option appears in the part number), shown in Fig 6.

Construction/Parts list (Fig 7)

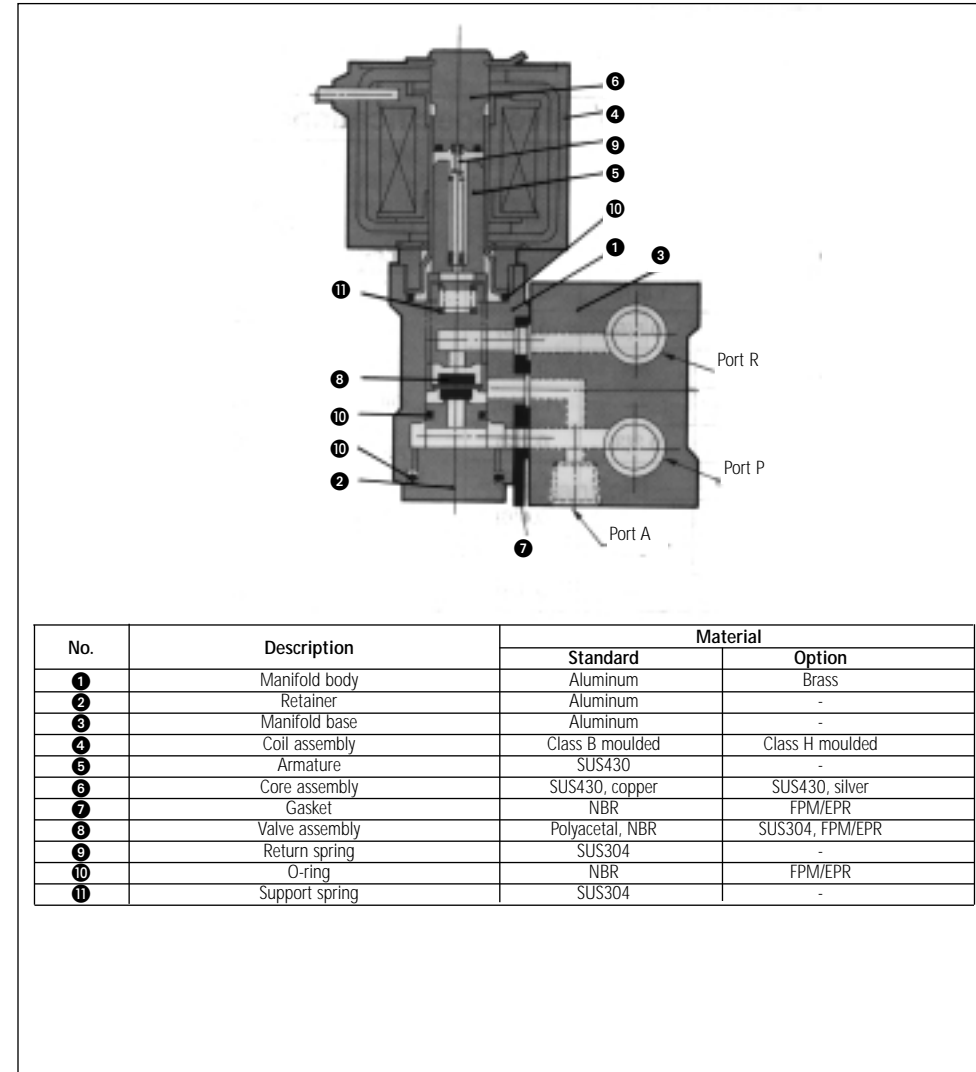

Fig 7

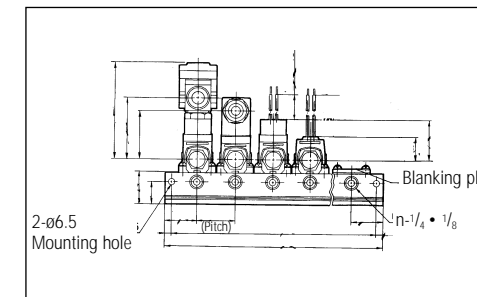

Fig 6

Ensure that gasket item 7 in drawing below is not damaged and free from any foreign bodies. Locate valve on manifold, being sure to connect the OUT port on the manifold with the centre port on the valve. Locate the 2 off mounting screws and tighten so as to achieve an air tight seal between the valve and the manifold.

Applicable fluids

VX31/32/33, 3 port solenoid valves

Standard	Water (standard, up to 60°C), air (standard, dry), turbine oil, spindle oil, Kerosene, vacuum (up to 1 torr), carbon dioxide (CO ₂), nitrogen gas (N ₂), Freon 11, 113, 114
----------	---

Option	Fluid	Option symbol
	Steam	(S.O)
Vacuum (up to 10 ⁻³ torr)	(V.M)	
Non-leak (10 ⁻³ atm or less)	(V.N)	
High temperature water	(X.E.N.P)	
High temperature oil	(D.N)	
Argon, Helium	(F)	
Others		

VVX31/32/33 Manifold series

Standard	Air (standard, dry), turbine oil, spindle oil, Kerosene, vacuum (up to 1 torr), carbon dioxide (CO ₂), nitrogen gas (N ₂), Freon 11, 113, 114
----------	---

Option	Fluid	Option symbol
	Vacuum (up to 10 ⁻³ torr)	(V/R)
	Non-leak (10 ⁻³ atm cc/sec or less)	(V/R)
	Argon, Helium	(F)
	Others	

Generally, the recommended viscosity of fluid is 50 cSt max. Fluids contaminated with foreign material can promote wear of the valve seat and iron core. To prevent this, place a filter/strainer immediately before the valve. A mesh of 80-100 micron is recommended. SMC valves are designed for use without lubricant. However, correctly lubricated air will increase the life of the valve.

CAUTION

These valves are NOT EXPLOSION PROOF. When using inflammable oil or gas, ensure that there is no leakage either inside or outside of the valve.

Fluid Temperature

Refer to the temperature range for each model. The temperature range changes according to the sealing material, coil insulation, power supply, etc.

Ambient conditions

Freezing. When using water in cold environments anti-freeze precautions should be taken. These include but are not limited to, draining of pumps and valves. When using a heater, avoid applying it to the coil. Freezing will result when the dew point of the medium is high and the ambient temperature is low or when a large volume of fluid flows within the valve. In such cases install a dryer, keep the valve body warm, or take other preventative measures.

Long period energisation or de-energisation

The valve energisation period depends on the type and viscosity of the fluid. When pure water is the medium, then the valve should be switched at least every 10 days. If the period is longer than 10 days, a system check mechanism should be implemented.

CAUTION

These valves are not intended for use as emergency system valves.

Vibration

These valves should not be subjected to more than 3G and in the case of non-leak type no more than 1G.

When you enquire about the product, please contact the following

SMC Corporation:

ENGLAND	Phone 01908-563888	TURKEY	Phone 212-2211512
ITALY	Phone 02-92711	GERMANY	Phone 6103-402-0
HOLLAND	Phone 020-5318888	FRANCE	Phone 01-64-76-10-00
SWITZERLAND	Phone 052-34-0022	SWEDEN	Phone 08-603 07 00
SPAIN	Phone 945-184100	AUSTRIA	Phone 02262-62-280
	Phone 902-255255	IRELAND	Phone 01-4501822
GREECE	Phone 01-3426076	DENMARK	Phone 8738-0800
FINLAND	Phone 09-68 10 21	NORWAY	Phone 67-12 90 20
BELGIUM	Phone 03-3551464	POLAND	Phone 48-22-6131847