



ORIGINAL INSTRUCTIONS

Instruction Manual

Precision regulator

Series: EIR40\* (basic type), EIR412 (air operated type)

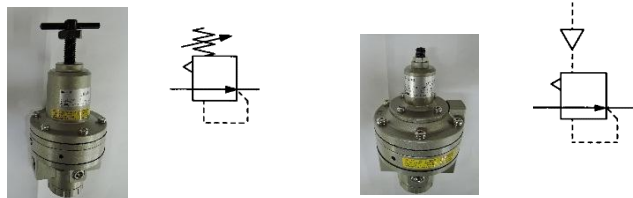

EIR40\*

EIR412

The intended use of this product is to precisely regulate pressure. Validated according to ISO 13849, see section 2.

1 Safety Instructions

These safety instructions are intended to prevent hazardous situations and/or equipment damage. These instructions indicate the level of potential hazard with the labels of "Caution", "Warning" or "Danger". They are all important notes for safety and must be followed in addition to International Standards (ISO/IEC)<sup>1)</sup>, and other safety regulations.

- <sup>1)</sup> ISO 4414: Pneumatic fluid power - - General rules relating to systems.
- ISO 4413: Hydraulic fluid power - - General rules relating to systems.
- IEC 60204-1: Safety of machinery - -Electrical equipment of machines. (Part 1: General requirements)
- ISO 10218-1: Manipulating industrial robots -Safety. etc.

This manual contains essential information for the protection of users and others from possible injury and/or equipment damage.

- Read this manual before using the product, to ensure correct handling,

and read the manuals of related apparatus before use.

- Keep this manual in a safe place for future reference.
- To ensure safety of personnel and equipment the safety instructions in this manual must be observed, along with other relevant safety practices.

	<b>Caution</b>	Caution indicates a hazard with a low level of risk which, if not avoided, could result in minor or moderate injury.
	<b>Warning</b>	Warning indicates a hazard with a medium level of risk which, if not avoided, could result in death or serious injury.
	<b>Danger</b>	Danger indicates a hazard with a high level of risk which, if not avoided, will result in death or serious injury.

Warning

- The compatibility of the product is the responsibility of the person who designs the equipment or decides its specifications.**
- Since the product specified here is used under various operating conditions, its compatibility with specific equipment must be decided by the person who designs the equipment or decides its specifications based on necessary analysis and test results. The expected performance and safety assurance of the equipment will be the responsibility of the person who has determined its compatibility with the product. This person should also continuously review all specifications of the product referring to its latest catalogue information, with a view to giving due consideration to any possibility of equipment failure when configuring the equipment.
- Only personnel with appropriate training should operate machinery and equipment.**

The product specified here may become unsafe if handled incorrectly. The assembly, operation and maintenance of machines or equipment including our products must be performed by an operator who is appropriately trained and experienced.

1 Safety Instructions - continued

- Do not service or attempt to remove product and machinery/equipment until safety is confirmed.**
  - The inspection and maintenance of machinery/equipment should only be performed after measures to prevent falling or runaway of the driven objects have been confirmed.
  - When the product is to be removed, confirm that the safety measures as mentioned above are implemented and the power from any appropriate source is cut, and read and understand the specific product precautions of all relevant products carefully.
  - Before machinery/equipment is restarted, take measures to prevent unexpected operation and malfunction.
- Contact SMC beforehand and take special consideration of safety measures if the product is to be used in any of the following conditions.**
  - Conditions and environments outside of the given specifications, or use outdoors or in a place exposed to direct sunlight.
  - Installation on equipment in conjunction with atomic energy, railways, air navigation, space, shipping, vehicles, military, medical treatment, combustions and recreation, or equipment in contact with food and beverages, emergency stop circuits, clutch and brake circuits in press applications, safety equipment or other applications unsuitable for the standard specification described in the product catalogue.
  - An application which could have negative effects on people, property, or animals requiring special safety analysis outside the scope of ISO 13849 described in this document.
  - Use in an interlock circuit, which requires the provision of double interlock for possible failure by using a mechanical protective function, and periodical checks to confirm proper operation.
- Always ensure compliance with relevant safety laws and standards.** All electrical work must be carried out in a safe manner by a qualified person in compliance with applicable national regulations.

Caution

- The product is provided for use in manufacturing industries.** The product herein described is basically provided for peaceful use in manufacturing industries.

If considering using the product in other industries, consult SMC beforehand and exchange specifications or a contract if necessary. If anything is unclear, contact your nearest sales branch.

2 Specifications

2.1 General Specifications

Model	EIR400	EIR401	EIR402	EIR412
Fluid	Compressed air (dry air)			
Proof pressure	1.5 MPa			
Max. supply pressure	1.0 MPa			
Min. supply pressure	Set pressure +0.1 MPa			
Set pressure range	0.01 to 0.2 MPa	0.01 to 0.4 MPa	0.01 to 0.7 MPa	0.01 to 0.7 MPa
Input signal pressure range	-			0.01 to 0.7 MPa
Sensitivity	Within 0.2% of full span			
Repeatability	Within ±0.5% of full span			
Linearity	-			Within ±1% of full span
Minimum frequency	1 cycle / 30 days			
Air consumption	12.4 L/min(ANR) or less			
Ambient and fluid temperature	-5 to 60°C (no freezing)			
Flow	Refer to 2.3			
Weight	Approx.1.0 kg (no attachment)		Approx.0.9 kg (no attachment)	
SUP./OUT port size	G1/4, G3/8, G1/2			
Pressure gauge port size	G1/4			
EXH port size	G1/4, G3/8			G1/8
IN port size	-			G1/8
Compressed air quality grade	[2,4,3]			

Table 1

2 Specifications – continued

Standards	Complies with the basic and well-ried safety principles of EN ISO 13849-2:2012
B <sub>10</sub> (Note 9)	740,000
B <sub>10d</sub> (Note9)	1,480,000

Notes:

- Note 1) Min. supply pressure: No flow condition on the outlet side.
- Note 2) Set pressure range: No flow condition on the outlet side.
- Note 3) Input signal pressure range: No flow condition on the outlet side.
- Note 4) Sensitivity: Indicates the minimum pressure range where the outlet side pressure can be adjusted on the outlet side of the precision regulator by fine adjustment of the input signal pressure. No flow on the outlet side.
- Note 5) Repeatability: Repeatability accuracy of the outlet pressure for each ON-OFF operation on the outlet side. The effect of pressure changes due to the change of regulator over time, temperature changes or vibration is not included in repeatability.
- Note 6) Linearity: Indicates the linearity of the outlet pressure against the input signal pressure. Conditions: Supply pressure of 1.0 MPa, no flow on the outlet side.
- Note 7) Air consumption: At supply pressure of 1.0 MPa.
- Note 8) Indicates the quality grade regarding the cleanliness of compressed air (solid particles, moisture or oil) specified in Compressed air quality grade: ISO 8573-1:2010.
- Note 9) Under SMC test conditions. The B<sub>10</sub> figure is estimated from SMC life tests. The B<sub>10d</sub> figure is derived from B<sub>10</sub> using the assumption in EN ISO 13849-1:2008 Annex C. Contact SMC for details.

2.2 Working principle

2.2.1 EIR40\* (basic type)

A clockwise rotation of set handle ① pushes flapper ⑥ down to close nozzle ⑦ causing air supply to bleed through fixed orifice ⑩ and push diaphragm B ④ down, resulting in opening supply valve ⑧. Supply pressure flows to outlet and acts on diaphragm A ③ which counteracts spring pressure and diaphragm B ④. This results in diaphragm B being pushed up to close supply valve ⑧ when the set pressure is reached. When the set pressure increases too much, this pressure is fed to act on diaphragm A ③ which opens flapper nozzle ⑦. This results in decreasing

pressure on diaphragm B ④ and raising supply valve stem to open exhaust valve ⑤ and exhausting forward pressure to atmosphere exhaust port ⑨.

Turning setting handle ① counterclockwise reverses the previous operation allowing the set pressure to relief through exhaust valve ⑤ until the lower set pressure is reached and balance is obtained.

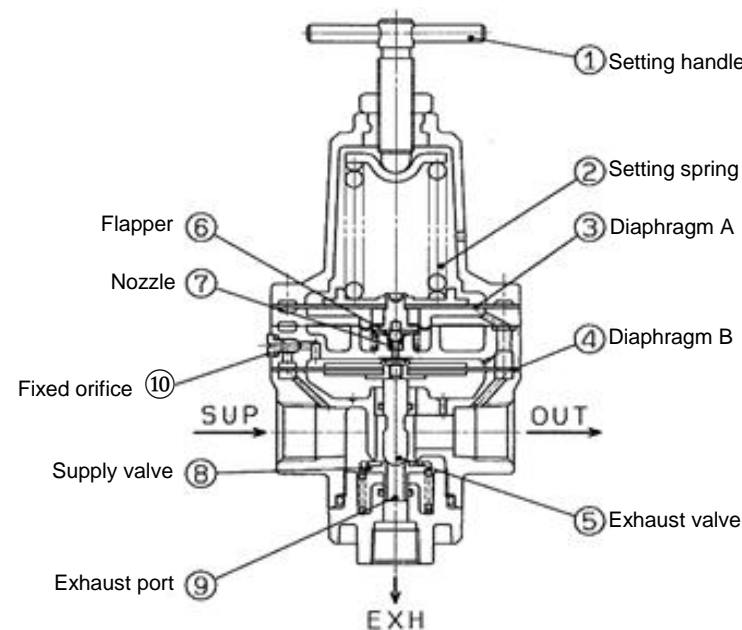

Figure 1

2 Specifications – continued

2.1.1 EIR412 (air operated type)

When the input signal rises, the pressure pushes diaphragm A ① to move flapper ④ onto nozzle ⑤. In result the supply pressure bleeds through fixed orifice ⑧ and pushes diaphragm B ② down, opening supply valve ⑥. The set pressure increases and is fed to act on diaphragm B ② to close supply valve ⑥. Diaphragm A ① acts against set pressure and balances pilot pressure, allowing flapper ④ to relief nozzle ⑤ and bleed to atmosphere.

When the set pressure increases too much, this pressure is fed to act on diaphragm A ① which lifts flapper ④ away from nozzle ⑤ and reduces pressure on diaphragm B ②. The exhaust valve ③ opens, allowing set pressure to exhaust to atmosphere through exhaust port ⑦. If the input signal is reduced, operation is reversed allowing forward pressure to exhaust until the lower set pressure balance is reached.

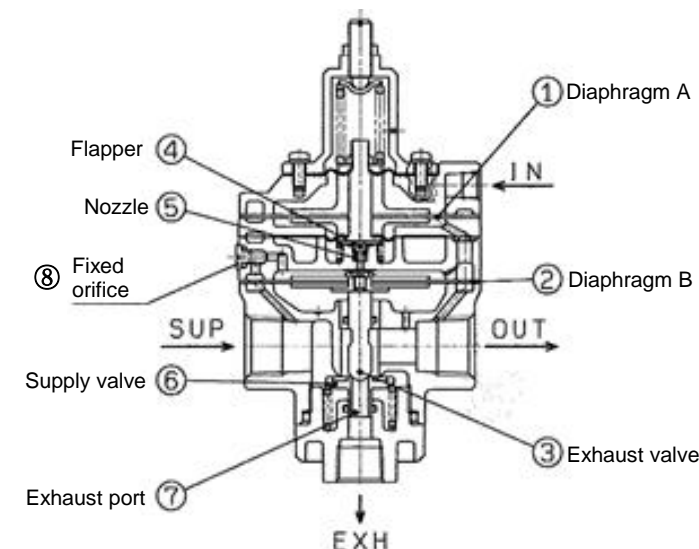

Figure 2

2.3 Flow characteristics

EIR400-F03 (Condition: supply pressure 0.5 MPa)	EIR401-F03 (Condition: supply pressure 0.7 MPa)
EIR402-F03 (Condition: supply pressure 1.0 MPa)	EIR412-F03 (Condition: supply pressure 1.0 MPa)

Table 2

- Note 10) Test method according to JIS B8372
- Note 11) Flow characteristics are affected by operating conditions or disturbance, therefore values shown in the graphs above are not guaranteed.

## 2 Specification – continued

### Caution

Special products might have specifications different from those shown in this section. Contact SMC for specific drawings. These drawings will give the appropriate specification details and compliance with the safety principles of ISO 13849, if applicable.

## 3 Installation

### 3.1 Installation

#### Warning

- Do not install the product unless the safety instructions have been read and understood.
- When installing the product, provide sufficient space for maintenance.

### 3.2 Environment

#### Warning

- Do not use in an environment where corrosive gases, chemicals, salt water or steam are present.
- Do not use in an explosive atmosphere.
- Do not expose to direct sunlight. Use a suitable protective cover.
- Do not install in a location subject to vibration or impact. Check the product specifications.
- Do not mount in a location exposed to radiant heat.
- If using in an atmosphere where there is possible contact with water drop-lets, oil, weld spatter, etc., take suitable preventive measures.
- Please consult SMC if leakage in atmosphere is not acceptable.

### 3.3 Piping

#### Warning

- When screwing in a fitting with the recommended tightening torque, hold the regulator body.
- If tightening torque is insufficient, loosening or leakage will occur.
- If the torque is excessive the thread will damage.
- If tightening is performed without holding the female thread side,

excessive force will be applied to the piping, bracket, etc. resulting in damage.

#### Recommended tightening torque [Unit: N·m]

Thread size	1/4	3/8	1/2
Torque	12 to 14	22 to 24	28 to 30

Table 3

- If torsional moment or bending moment other than the equipment's own weight is applied, it can cause damage. Therefore, support the external piping separately.
- Inflexible piping such as steel piping is subject to excessive moment from the piping side or vibration, therefore, place a flexible tube or others to prevent it.
- When mounting, connect after checking the port indication.

#### Caution

- Before piping make sure to clean up chips, cutting oil, dust etc.
- When installing piping or fittings, ensure sealant material does not enter inside the port. When using seal tape, leave 1.5 to 2 threads exposed on the end of the pipe/fitting.
- Tighten fittings to the specified tightening torque.

### 3.4 Air source

#### Warning

- Use compressed air as fluid. Consult SMC if you want to use other fluid.
- If compressed air contains chemicals, synthetic oil containing organic solvent, salt or corrosive gases, do not use it because it can cause damage or malfunction.
- If the drain removal from air filter and mist separator is missed, drain will flow out to the outlet side and may result in malfunction of the pneumatic equipment. When removing drain is difficult, use of a filter with an auto drain is recommended.

## 3 Installation – continued

### Caution

- If the supply pressure line contains drain or particulate, the fixed throttle can become clogged leading to a malfunction. Therefore, install a mist separator (SMC Series AM, AFM) in addition to an air filter (SMC Series AF) and carry out a regular drain removal and element replacement. Check that the air supply system satisfies the specifications in Section 2.
- Never use a lubricator on the supply side of the regulator as this will inevitably cause the fixed throttle to become clogged and result in a malfunction. If lubrication is required for terminal devices, connect a lubricator on the outlet side of the regulator to prevent the outlet air from flowing back to the regulator.
- ※ If the fixed orifice is clogged or is going to become clogged, the following effect might occur:
  - No output
  - The set pressure decreases.
  - The set pressure is not stable.
  - The outlet pressure rise is delayed.

### 3.5 Operation

#### Caution

- If a directional switching valve (solenoid valve, mechanical valve, etc.) is mounted on the supply side of the regulator and repeatedly switched On and Off, wear of the nozzle/flapper section will be accelerated and a discrepancy in the setting value may occur. Therefore, avoid using a directional switching valve on the supply side. If a direction switching valve will be used, install it on the output side of the precision regulator.
- Air is normally released from the bleed hole (the hole on the side of the body's mid-section). This is a necessary consumption of the air based on the construction of the precision regulator and is not an abnormality.
- Make sure to tighten the lock nut after pressure adjustment.
- There may be pulsation or noise depending on the pressure conditions, piping conditions and ambient environment. In this case, it is possible to improve the problem by changing the pressure and piping conditions. If the problem is not improved, contact your SMC sales representative.
- The set pressure may vary depending on the elapsed time and change in ambient temperature after pressure setting. If the setting value varies, adjust with the knob.

- The set pressure might change due to the effect of ambient or fluid temperature. If the set pressure becomes different due to the effect of temperature, consider controlling the ambient and fluid temperature.
- When installing a pressure gauge to the product, do not apply pressure more than the maximum display pressure. This will cause a malfunction.
- The capacity of the output side is large and when used for a relief function, the exhaust sound will be loud when being relieved. Therefore, operate with a silencer (SMC Series AN) mounted on the EXH port.
- Since the set pressure of the air operated type regulator is the same as the input signal pressure, select a type of regulator (general purpose or precision type) for input signal pressure adjustment according to the application.
- The screw on the topmost section of the air operated type regulator is a zero point adjustment screw which is locked at the factory and requires no adjustment for operation. If this screw is adjusted after delivery, it might cause a malfunction and will not meet the specification. Therefore do not adjust this screw after delivery.

## 4 How-to-Order

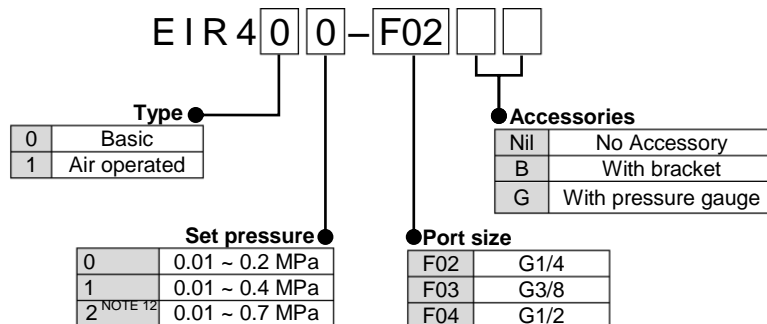

Note 12) Set pressure range is 0.01 to 0.7 MPa only for the EIR412 air operated type.

## 5 Outline dimensions (mm)

### 5.1 EIR40\* (basic type)

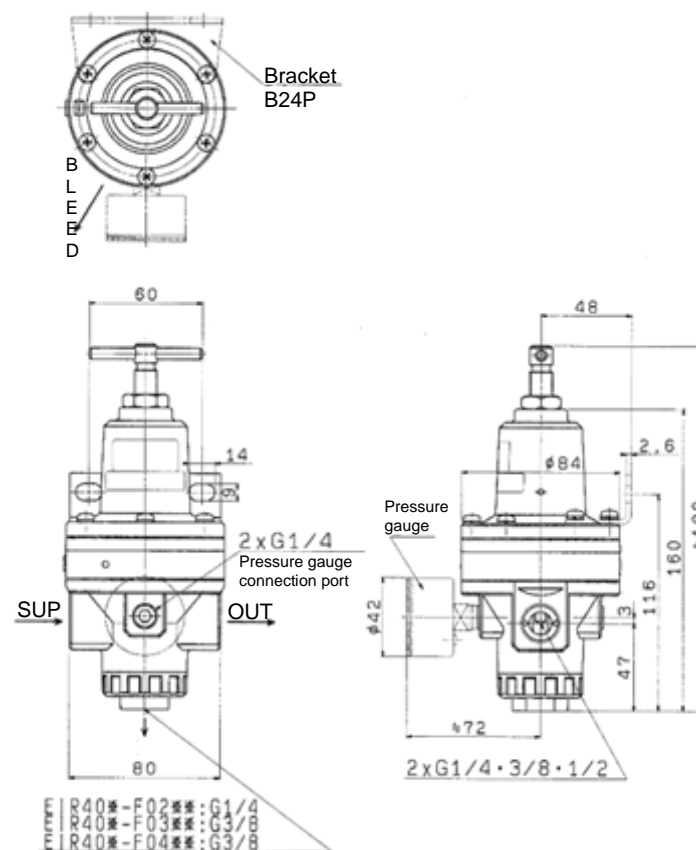

### 5.2 EIR412 (air operated type)

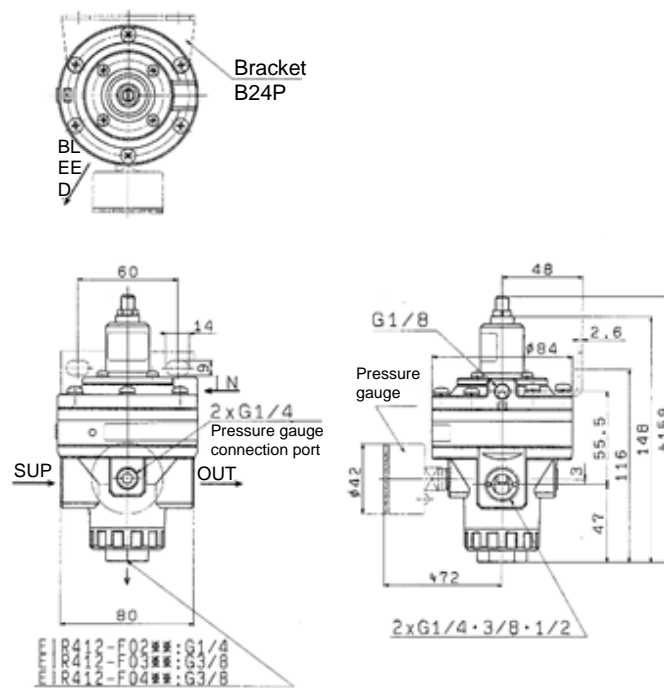

## 6 Maintenance

### 6.1 General Maintenance

#### Caution

- Not following proper maintenance procedures could cause the product to malfunction and lead to equipment damage.
- If handled improperly, compressed air can be dangerous. Maintenance of pneumatic systems should be performed only by qualified personnel.
- Before performing maintenance, turn off the power supply and be sure to cut off the supply pressure. Confirm that the air is released to atmosphere.
- After installation and maintenance, apply operating pressure and power to the equipment and perform appropriate functional and leakage tests to make sure the equipment is installed correctly.
- Do not make any modification to the product.
- Do not disassemble the product, unless required by installation or maintenance instructions.
- Never handle machines/devices or remove the equipment until safety is secured.
- If a pressure gauge is to be mounted, remove the plug after reducing the set pressure to '0'.
- As the rubber parts such as diaphragms, O-rings and seals are consumables, it is recommended that they are inspected every year and replaced every 3 years.
- Ensure that drain is removed regularly from a filter and others on the supply side and elements and piping are cleaned or replaced. As a guide, carry out a monthly or quarterly inspection though this differs depending on the operating conditions.

## 7 Limitations of Use

### 7.1 Limited warranty and Disclaimer/Compliance Requirements

- The product used is subject to the following "Limited warranty and Disclaimer" and "Compliance Requirements". Read and accept them before using the product.

#### Limited warranty and Disclaimer

- The warranty period of the product is 1 year in service or 1.5 years

after the product is delivered, whichever is first<sup>(1)</sup>. Also, the product may have specified durability, running distance or replacement parts. Please consult your nearest sales branch.

2) For any failure or damage reported within the warranty period which is clearly our responsibility, a replacement product or necessary parts will be provided.

This limited warranty applies only to our product independently, and not to any other damage incurred due to the failure of the product.

3) Prior to using SMC products, please read and understand the warranty terms and disclaimers noted in the specified catalogue for the particular products.

<sup>(1)</sup> Vacuum pads are excluded from this 1 year warranty.

A vacuum pad is a consumable part, so it is warranted for a year after it is delivered. Also, even within the warranty period, the wear of a product due to the use of the vacuum pad or failure due to the deterioration of rubber material are not covered by the limited warranty.

#### Compliance Requirements

- The use of SMC products with production equipment for the manufacture of weapons of mass destruction (WMD) or any other weapon is strictly prohibited.
- The exports of SMC products or technology from one country to another are governed by the relevant security laws and regulations of the countries involved in the transaction. Prior to the shipment of a SMC product to another country, assure that all local rules governing that export are known and followed.

#### Caution

- SMC products are not intended for use as instruments for legal metrology.

Measurement instruments that SMC manufactures or sells have not been qualified by type approval tests relevant to the metrology (measurement) laws of each country.

## 7 Limitations of Use - continued

Therefore, SMC products cannot be used for business or certification ordained by the metrology (measurement) laws of each country.

### Warning

Any use in an ISO 13849 system must be within the specified limits and application conditions. The user is responsible for the specification, design, implementation, validation and maintenance of the safety system (SRP/CS).

## 8 Contacts

<b>AUSTRIA</b>	SMC Pneumatik GmbH, Girakstrasse 8, AT-2100 Korneuburg, Austria
<b>BELGIUM</b>	SMC Pneumatics N.V./S.A. Nijverheidsstraat 20, B-2160 Wommelgem, Belgium
<b>BULGARIA</b>	SMC Industrial Automation Bulgaria EOOD, Business Park Sofia, Building 8-6th floor, BG-1715 Sofia, Bulgaria
<b>CROATIA</b>	SMC IndustrijskaAutomatikad.o.o. ZagrebačkaAvenija 104,10 000 Zagreb
<b>CZECH REP.</b>	SMC Industrial Automation CZ s.r.o. Hudcova 78a, CZ-61200 Brno, Czech Republic
<b>DENMARK</b>	SMC Pneumatik A/S, Egeskovvej 1, DK-8700 Horsens, Denmark
<b>ESTONIA</b>	SMC Pneumatics Estonia Oü, Laki 12, EE-10621 Tallinn, Estonia
<b>FINLAND</b>	SMC Pneumatics Finland Oy, PL72, Tiistinniityntie 4, SF-02031 Espoo, Finland
<b>FRANCE</b>	SMC Pneumatique SA. 1, Boulevard de Strasbourg, Parc Gustave Eiffel, Bussy Saint Georges, F-77607 Marne La ValleeCedex 3, France
<b>GERMANY</b>	SMC Pneumatik GmbH, Boschring 13-15, 63329 Egelsbach, Germany
<b>GREECE</b>	SMC Italia Hellas Branch, Anageniseos 7-9-P.C. 14342 N.Philadelphia, Athens, Greece
<b>HUNGARY</b>	SMC Hungary IpariAutomatizálásiKft. Torbágy u. 19, HU-2045 Törökbálint, Hungary
<b>IRELAND</b>	SMC Pneumatics (Ireland) Ltd.2002 Citywest Business Campus, Naas Road, Saggart, Co. Dublin, Ireland
<b>ITALY</b>	SMC Italia S.p.A.Via Garibaldi 62, I-20061Carugate, (Milano), Italy
<b>LATVIA</b>	SMC Pneumatics Latvia SIA, Dzelzavas str. 120g, Riga, LV-1021, Latvia
<b>LITHUANIA</b>	UAB "SMC Pneumatics", Oslo g. 1, LT-04123 Vilnius, Lithuania
<b>NETHERLANDS</b>	SMC Pneumatics B.V.De Ruyterkade 120, NL-1011 AB Amsterdam, the Netherlands
<b>NORWAY</b>	SMC Pneumatics Norway AS, Vollsveien 13 C, GranfosNæringspark, N-1366 Lysaker, Norway
<b>POLAND</b>	SMC Industrial Automation, Polska Sp z o.o. 02-826 Warszawa, ul. Poloneza 89
<b>PORTUGAL</b>	SMC España S.A. Zuazobidea 14, 01015 Vitoria, Spain
<b>ROMANIA</b>	SMC Romania S.r.l. StrFrunzei 29, Sector 2, Bucharest, Romania
<b>RUSSIA</b>	SMC Pneumatik LLC. Business centre, building 3, 15 Kondratjevskij prospect, St.Petersburg, Russia, 195197

<b>SLOVAKIA</b>	SMC PriemyselnáAutomatizáciaSpols.r.o. Fantranská 1223, Teplickanadvahom, 01301, Slovakia
<b>SLOVENIA</b>	SMC IndustrijskaAvtomatikad.o.o. Mirnskecesta 7, SLO-8210 Trebnje, Slovenia
<b>SPAIN</b>	SMC España S.A. Zuazobidea 14, 01015 Vitoria, Spain
<b>SWEDEN</b>	SMC Pneumatics Sweden AB,Ekhagsvägen 29-31, SE-141 71 Segeltorp, Sweden
<b>SWITZERLAND</b>	SMC Pneumatik AG,Dorfstrasse 7, Postfach, 8484 Weislingen, Switzerland
<b>TURKEY</b>	SMC PnömatikSanayiTicaretveServis A.Ş. GülbaharCaddesi, Aydın Plaza, No: 9/4 Güneşli – 34212 , Istanbul
<b>UK</b>	SMC Pneumatics (U.K.) Ltd. Vincent Avenue, Crownhill, Milton Keynes, Buckinghamshire MK8 0AN, United Kingdom

## SMC Corporation

URL : [http:// www.smcworld.com](http://www.smcworld.com) (Global) [http:// www.smceu.com](http://www.smceu.com) (Europe)  
 'SMC Corporation, Akihabara UDX15F, 4-14-1, Sotokanda, Chiyoda-ku, Tokyo 101 0021  
 Specifications are subject to change without prior notice from the manufacturer.  
 © 2016 SMC Corporation All Rights Reserved.  
 Template DKP50047-F-085D