



ORIGINAL INSTRUCTIONS



Refer to Declaration of Conformity for relevant Directives

Instruction Manual
3 Port Solenoid Valve
Direct Operated Poppet Type
Series VEX3

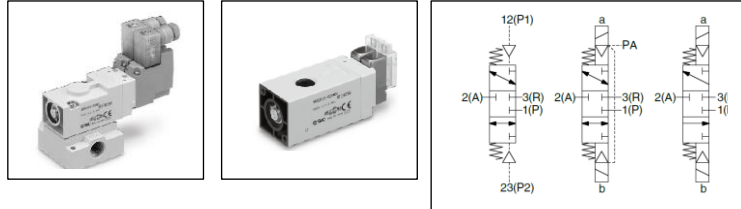

The intended use of this valve is for immediate and emergency stops of a large size cylinder.

1 Safety Instructions

These safety instructions are intended to prevent hazardous situations and/or equipment damage. These instructions indicate the level of potential hazard with the labels of "Caution," "Warning" or "Danger." They are all important notes for safety and must be followed in addition to International Standards (ISO/IEC)^{*)}, and other safety regulations.

- ^{*)} ISO 4414: Pneumatic fluid power - - General rules relating to systems.
- ISO 4413: Hydraulic fluid power - - General rules relating to systems.
- IEC 60204-1: Safety of machinery - -Electrical equipment of machines. (Part 1: General requirements)
- ISO 10218-1: Manipulating industrial robots -Safety.etc.

This manual contains essential information for the protection of users and others from possible injury and/or equipment damage.

- Read this manual before using the product, to ensure correct handling, and read the manuals of related apparatus before use.
- Keep this manual in a safe place for future reference.
- To ensure safety of personnel and equipment the safety instructions in this manual must be observed, along with other relevant safety practices.

	Caution	Caution indicates a hazard with a low level of risk which, if not avoided, could result in minor or moderate injury.
	Warning	Warning indicates a hazard with a medium level of risk which, if not avoided, could result in death or serious injury.
	Danger	Danger indicates a hazard with a high level of risk which, if not avoided, will result in death or serious injury.

Warning

- **The compatibility of the product is the responsibility of the person who designs the equipment or decides its specifications.**
- Since the product specified here is used under various operating conditions, its compatibility with specific equipment must be decided by the person who designs the equipment or decides its specifications based on necessary analysis and test results. The expected performance and safety assurance of the equipment will be the responsibility of the person who has determined its compatibility with the product. This person should also continuously review all specifications of the product referring to its latest catalogue information, with a view to giving due consideration to any possibility of equipment failure when configuring the equipment.

- **Only personnel with appropriate training should operate machinery and equipment.**

The product specified here may become unsafe if handled incorrectly.

The assembly, operation and maintenance of machines or equipment including our products must be performed by an operator who is appropriately trained and experienced.

- **Do not service or attempt to remove product and machinery/equipment until safety is confirmed.**

1) The inspection and maintenance of machinery/equipment should only be performed after measures to prevent falling or runaway of the driven objects have been confirmed.

2) When the product is to be removed, confirm that the safety measures as mentioned above are implemented and the power from any appropriate source is cut, and read and understand the specific product precautions of all relevant products carefully.

3) Before machinery/equipment is restarted, take measures to prevent unexpected operation and malfunction.

- **Contact SMC beforehand and take special consideration of safety measures if the product is to be used in any of the following conditions.**

1) Conditions and environments outside of the given specifications, or use outdoors or in a place exposed to direct sunlight.

2) Installation on equipment in conjunction with atomic energy, railways, air navigation, space, shipping, vehicles, military, medical treatment, combustions and recreation, or equipment in contact with food and beverages, emergency stop circuits, clutch and brake circuits in press applications, safety equipment or other applications unsuitable for the standard specification described in the product catalogue.

3) An application which could have negative effects on people, property, or animals requiring special safety analysis.

4) Use in an interlock circuit, which requires the provision of double interlock for possible failure by using a mechanical protective function, and periodical checks to confirm proper operation.

- **Always ensure compliance with relevant safety laws and standards.**

All electrical work must be carried out in a safe manner by a qualified person in compliance with applicable national regulations.

Caution

- **The product is provided for use in manufacturing industries.**

The product herein described is basically provided for peaceful use in manufacturing industries.

If considering using the product in other industries, consult SMC beforehand and exchange specifications or a contract if necessary. If anything is unclear, contact your nearest sales branch.

- **Ensure that the air supply system is filtered to 5 µm.**

2 Specifications

2.1 Specifications

VEX3 specifications

Model	Body ported	VEX312□-(01,02)	VEX332□-(02,03,04)
	Base mounted	VEX322□-(01,02)	VEX342□-(02,03,04)
Operation type Air operated, External pilot solenoid, Internal pilot solenoid			
Fluid Air			
Air operated operating pressure range (MPa)	Operating pressure range	-101.2kPa to 1.0	
	Pilot pressure range	0.2 to 1.0	
Internal pilot operating pressure range (MPa) 0.2 to 0.7			
External pilot solenoid	Operating pressure range	-101.2kPa to 1.0	
	Pilot pressure range	0.2 to 0.7	
Ambient and fluid temperature 0 to 50°C (Air operated 60°C)			
Response time (Pilot pressure 0.5 MPa) 40 ms or less 60 ms or less			
Max. operating frequency 3Hz.			
Mounting Free			
Lubrication Not required (Use turbine oil Class 1 ISO VG32, if lubricated.)			

Table 1

Note1) In the case of AC, it will be 96ms or less.
 Note2) Non-lubricated specifications are not available for this product.

Pilot Solenoid Valve Specifications

Model		VEX3121, VEX3221, VEX3321, VEX3421 VEX3122, VEX3222, VEX3322, VEX3422		
Pilot valve		V114□, V115□		
Electrical entry		Grommet, L plug connector, M plug connector, DIN terminal		
Coil rated Voltage(V)	AC(50/60Hz)	100V, 110V, 200V, 220V		
	DC	3V, 5V, 6V, 12V, 24V		
Allowable voltage fluctuation		-10 to +10% of rated voltage		
Apparent power [VA]	AC	G, L, M	100V	0.78(With light : 0.81)
			110V	0.86(With light : 0.89)
			200V	1.18(With light : 1.22)
			220V	1.30(With light : 1.34)
	D	100V	0.78(With light : 0.87)	
		110V	0.86(With light : 0.97)	
		200V	1.15(With light : 1.30)	
		220V	1.27(With light : 1.46)	
Power consumption (W)	DC	G, L, M	1.0(With light : 1.1)	
		D	1.0(With light : 1.1)	

Table 2

Note) S, Z type allowable voltage fluctuation : DC24V: -7 to +10%
 DC12V: -4 to +10%

2.2 Flow rate characteristics

2.2.1 Valve

Model	Port size	Flow rate characteristics				
		1→2 (P→A)		2→1 (A→P)		
		C	b	C	b	
Body ported	VEX312□-01	1/8	2.4	0.19	2.4	0.31
	VEX312□-02	1/4	3.5	0.35	3.3	0.49
	VEX332□-02	1/4	4.1	0.36	4.3	0.42
	VEX332□-03	3/8	8.7	0.29	7.9	0.52
Base mounted	VEX332□-04	1/2	9.8	0.37	9.6	0.52
	VEX322□-01	1/8	3.3	0.34	3.5	0.39
	VEX322□-02	1/4	4.1	0.28	4.1	0.39
	VEX342□-02	1/4	8.1	0.34	7.9	0.39
	VEX342□-03	3/8	12	0.26	12	0.29
	VEX342□-04	1/2	13	0.20	13	0.24

Model	Port size	Flow rate characteristics				
		3→2 (R→A)		2→3 (A→R)		
		C	b	C	b	
Body ported	VEX312□-01	1/8	2.3	0.36	2.5	0.22
	VEX312□-02	1/4	3.1	0.46	3.5	0.33
	VEX332□-02	1/4	4.1	0.41	4.6	0.25
	VEX332□-03	3/8	7.8	0.51	8.7	0.33
Base mounted	VEX332□-04	1/2	9.1	0.53	11	0.37
	VEX322□-01	1/8	3.3	0.37	3.5	0.36
	VEX322□-02	1/4	3.8	0.38	4.4	0.23
	VEX342□-02	1/4	8.2	0.33	8.1	0.37
VEX342□-03	3/8	12	0.28	13	0.28	
VEX342□-04	1/2	12	0.29	14	0.20	

3 Installation

3.1 Installation

Warning

Do not install the product unless the safety instructions have been read and understood.

3.2 Environment

Warning

- Do not use in an atmosphere having corrosive gases, chemicals, sea water, water, water steam, or where there is direct contact with any of these.
- Do not use in an environment where flammable gas or explosive gas exists. Usage may cause a fire or explosion. The products do not have an explosion proof construction.
- Do not use in a place subject to heavy vibration and/or shock.
- The valve should not be exposed to prolonged sunlight. Use a protective cover. Note that the valve is not for outdoor use.

- Remove any sources of excessive heat.
- If it is used in an environment where there is possible contact with oil, weld spatter, etc., exercise preventive measures.
- When the solenoid valve is mounted in a control panel or it's energized for a long time, make sure ambient temperature is within the specification of the valve.

Caution

- **Temperature of ambient environment**
 Use the valve within the range of the ambient temperature specification of each valve. In addition, pay attention when using the valve in environments where the temperature changes drastically.

- **Humidity of ambient environment**

- When using the valve in environments with low humidity, take measures to prevent static.
- If the humidity rises, take measures to prevent the adhesion of water droplets on the valve.

3.3 Piping

Caution

- Before piping make sure to clean up chips, cutting oil, dust etc.
- When installing piping or fittings, ensure sealant material does not enter inside the port. When using pipe tape, leave 1 thread exposed at the end of the threads.
- Tighten fittings to the specified tightening torque.

Thread	Tightening Torque
Rc 1/8	3 to 5 Nm
Rc 1/4	8 to 12 Nm
Rc 3/8	15 to 20 Nm
Rc 1/2	20 to 25 Nm

Table 3

3.4 Lubrication

Caution

- **Actuator drive**
 When an actuator, such as a cylinder, is to be driven using a valve, take appropriate measures (install a cover or barrier) to prevent potential danger caused by actuator operation.

- **Intermediate stops**

Due to the compressibility of air, it is difficult for this product to make a piston stop at the required intermediate position accurately and precisely.

Furthermore, since valves and cylinders are not guaranteed for zero air leakage, it may not be possible to hold a stopped position for an extended period of time.

Please contact SMC if it is necessary to hold a stopped position for an extended period of time.

- **Effect of back pressure when using a manifold.**

Use caution when the valve is used on a manifold, because an actuator may malfunction due to back-pressure.

- **Holding of pressure (including vacuum)**

Since the valves are subject to air leakage, they cannot be used for applications such as holding pressure (including vacuum) in a pressure vessel.

- **Not suitable for use as an emergency shut-off valve, etc.**

These valves are not designed for safety applications such as an emergency shutoff valve.

If the valves are used for the mentioned applications, additional safety measures should be adopted.

- **Release of residual pressure**

For maintenance purposes install a system for releasing residual pressure. Ensure that the residual pressure between the valve and the cylinder is released.

- **Operation in a vacuum condition**

When a valve is used for switching a vacuum, take measures to install a suction filter or similar to prevent external dust or other foreign matter from entering inside the valve.

In addition, at the time of vacuum adsorption, be sure to vacuum at all times. Failure to do so may result in foreign matter sticking to the adsorption pad, or air leakage causing the work piece to drop.

Use of the VEX3 series solenoid type product

When using the VEX3 series solenoid type for the first time, actuators may travel in an unexpected direction depending on the switching position of the valve. Implement measures to prevent any danger from occurring when operating the actuator.

Ventilation

Provide ventilation when using a valve in a confined area, such as in a closed control panel.

For example, install a ventilation opening, etc. in order to prevent pressure from increasing inside of the confined area and to release the heat generated by the valve.

Energizing for extended periods of time

Caution hot surface

* Be aware that the valve surface may get hot.

If a valve will be continuously energized for an extended period of time, the temperature of the valve will increase due to the heat generated by the coil. This will likely adversely affect the performance of the solenoid valve and any nearby peripheral equipment. Therefore, when it is continuously energized for an extended period of time or when the energized period per day is longer than the de-energized period, use VEX3 air operated type product. For pilot air operation, use a low-wattage type or continuous duty type valve.

As a valve not mentioned above can also be used depending on the operating conditions (in particular, DC specification valves), please contact SMC for further information.

For applications such as mounting a valve on a control panel, incorporate measures to limit the heat radiation so that it is within the operating temperature range. Do not touch the valves with bare hands during or after energization. In particular, note that the temperature rise will be greater if the product is energized for extended periods of time.

Disassembly and modification prohibited

Do not disassemble the product or make any modifications, including additional machining. It may cause human injury and/or an accident and will void the warranty.

3.5 Selection

Caution

Confirm the specifications.

Do not operate at pressures or temperatures, etc. beyond the range of specifications, as this can cause damage or malfunction. (Refer to specifications in catalogue).

3.6 Lubrication

Warning

1. The product has been lubricated by the manufacturer, and does not require lubrication maintenance.
2. If a lubricant is used in the system, use class 1 turbine oil (no additive), ISO VG32. For details about lubricant manufacturers' brands, refer to SMC website. Additionally, please contact SMC for details about class 2 turbine oil (with additives) ISO VG32. Once lubricant is utilized within the system, since the original lubricant applied within the product during manufacturing will be washed away, please continue to supply lubrication to the system. Without continued lubrication, malfunctions could occur.

Lubrication amount

If the lubrication amount is excessive, the oil may accumulate inside the pilot valve, causing malfunction or response delay. So, do not apply a large amount of oil. When a large amount of oil needs to be applied, use an external pilot type to put the supply air on the pilot valve side in the non-lube state. This prevents accumulation of oil inside the pilot valve.

3.7 Indicator Light/Surge Voltage Suppressor

Caution

Surge suppression should be specified by using the appropriate part number. In ISO 13849 validated systems, if a valve type without suppression is used, suppression must be provided by the host controller.

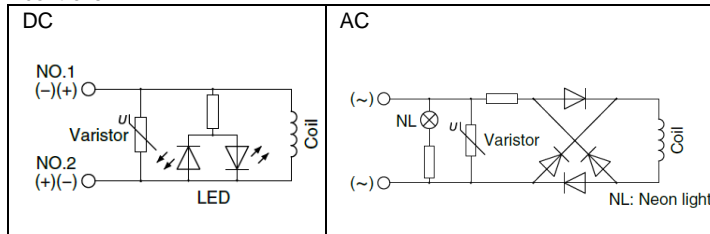

Figure 1

3.8 Electrical Connection

Caution

DIN terminal is connected as shown in Figure 2. Connect to the corresponding power supply.

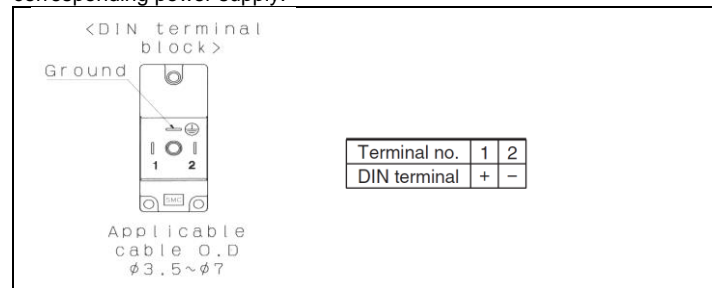

Figure 2

3.9 Lead wire color

Voltage	Color
100VAC	Blue
200VAC	Red
DC	Red(+), Black(-)
Others	Grey

Table 4

3.10 Manifold

Caution

1. Each valve is fixed to the manifold base with two M4 or M5 mounting screws. Tighten the screws firmly when re-mounting.
 2. For mounting, tighten M4, or equivalent screws, evenly to the manifold base.
- Tightening torque of the mounting screw (M4): 1.5 N·m, (M5):3.0 N·m

3.11 Exhaust Port

Caution

For the common exhaust type, pressurization or evacuation of the 3(R) port can cause a malfunction.

3.12 How to Install DIN Terminal – see Figure 3

1. Connection

1. Loosen the holding screw and pull the connector out of the solenoid valve terminal block.
2. After removing the holding screw, insert a flat head screwdriver, etc. into the notch on the bottom of the terminal block and pry it open, separating the terminal block and the housing.
3. Loosen the terminal screws (slotted screws) on the terminal block, insert the cores of the lead wires into the terminals according to the connection method, and fasten them securely with the terminal screws.
4. Secure the cord by fastening the ground nut.

Caution

When making connections, take note that using other than the supported size (φ3.5 to φ7) heavy-duty cord will not satisfy IP65 (enclosure) standards. Also, be sure to tighten the ground nut and holding screw within their specified torque ranges.

2. Changing the entry direction

After separating the terminal block and housing, the cord entry can be changed by attaching the housing in the desired direction (4 directions at 90° intervals).

* When equipped with a light, be careful not to damage the light with the cord's lead wires.

3. Precautions

Plug in and pull out the connector vertically without tilting to one side.

4. Compatible cable

Cord O.D.: φ3.5 to φ7
(Reference) 0.5 mm², 2-core or 3-core, equivalent to JIS C 3306

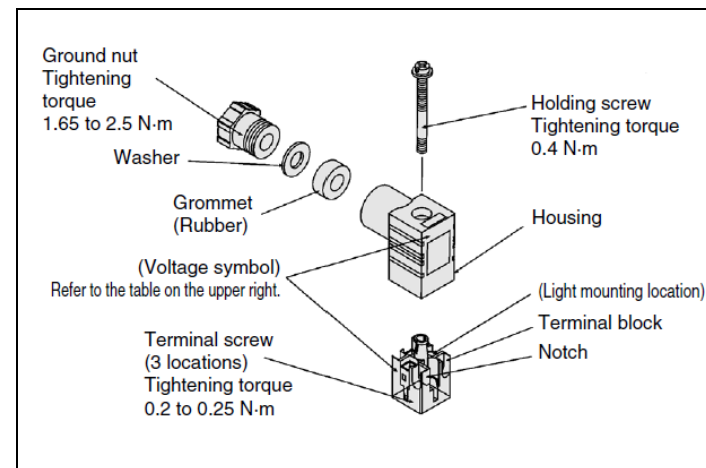

Figure 3

5. DIN Connector Part Number

<Type D>

Without light	SY100-61-1
---------------	------------

With light

Rated voltage	Voltage symbol	Part number
24VDC	24V	SY100-61-3-05
12VDC	12V	SY100-61-3-06
100 VAC	100V	SY100-61-2-01
200 VAC	200	SY100-61-2-02
110 VAC	110V	SY100-61-2-03
220 VAC	220V	SY100-61-2-04

Circuit Diagram with Light

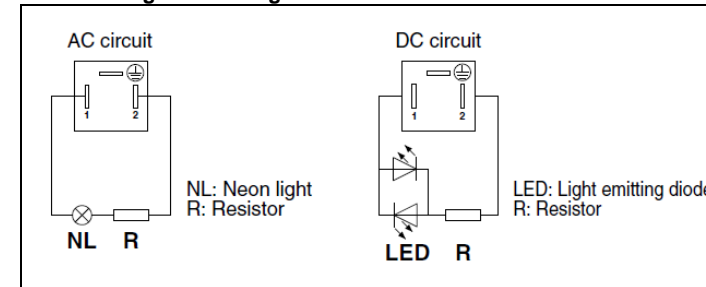

Figure 4

4 Settings

4.1 Manual Override

Caution

Since connected equipment will operate when the manual override is activated, confirm that conditions are safe prior to activation.

- Non-locking push type
- Locking slotted
- Push-turn locking slotted type
- Push-turn locking lever type

5 How to Order

Refer to the catalogue for this information.

6 Maintenance

6.1 General Maintenance

Caution

- Not following proper maintenance procedures could cause the product to malfunction and lead to equipment damage.
- If handled improperly, compressed air can be dangerous. Maintenance of pneumatic systems should be performed only by qualified personnel.
- Before performing maintenance, turn off the power supply and be sure to cut off the supply pressure. Confirm that the air is released to atmosphere.
- After installation and maintenance, apply operating pressure and power to the equipment and perform appropriate functional and leakage tests to make sure the equipment is installed correctly.
- Do not make any modification to the product.
- Do not disassemble the product, unless required by installation or maintenance instructions.
- **Low frequency operation**
Valves should be operated at least once every 30 days to prevent malfunction. (Use caution regarding the air supply).
- If the volume of air leakage increases or the valve does not operate normally, do not use the valve. Perform periodic maintenance of the valve to confirm the operating condition, and if there is any air leakage.

6.2 Supply air

Warning

Use clean air

If the compressed air supply includes chemicals, synthetic materials (including organic solvents), salinity, corrosive gas etc., it can lead to damage or malfunction.

Install an air filter

Install an air filter at the upper streamside of the valve. Filtration degree should be 5 μm or less.

6.3 Blanking plate assembly

Description	Part no.	
	VVEX2	VVEX4
Blanking Plate (with gasket and screws)	VEX1-17-3A	VEX4-5-3A

- For blanking off any spare stations on the manifold assembly.
- Assemble blanking plate to manifold block ensuring gasket is present.
- Torque tighten mounting screws to a torque of VVEX2:1.5 N·m, VVEX4: 3.0N m.

Caution

- Before disassembly, be sure to turn off electric power and air supplies.
- Confirm that the air has been completely exhausted before performing any work.
- Take care not to get scratches or dirt etc. on the seals, as this can cause leakage.

6.4 Replacement parts list

Description	VEX312□-**-	VEX322□-**-	VEX332□-**-	VEX342□-**-
Bracket (with bolt and washer)	VEX1-18-1A	-	-	-
Foot bracket (with bolt and washer)	VEX1-18-2A	-	VEX3-32-2A	-
Silencer for pilot exhaust port (PE) <small>Note 1)</small>	AN120-M5			
Sub plate	-	VEX1-9-2 (1) (2)	-	VEX4-2A-1 (1) (2)
Base gasket	-	VEX1-11-2	-	VEX4-4
Function plate between pilot valve and cover (with gasket)	-	-	-	-
Pilot valve <small>Note 2)</small>	Grommet L-connector M-connector	V114□-□□□□		
	DIN terminal	V115□-□□□		

Note 1) For solenoid valve only.

Note 2) Refer to SMC catalog for pilot valve part numbers.

Screw tightening torque V114⁴□ : 0.14 to 0.17 Nm

Select the symbols from the table below for (1) and (2).

Symbol	(1) Port size		(2) Thread type	
	VEX322□	VEX342□	Nil	Rc
A	1/8	1/4	F	G
B	1/4	3/8	N	NPT
C	-	1/2	T	NPTF

7 Limitations of Use

7.1 Limited warranty and Disclaimer/Compliance Requirements

• **The product used is subject to the following “Limited warranty and Disclaimer” and “Compliance Requirements”. Read and accept them before using the product.**

• **Limited warranty and Disclaimer**

1) The warranty period of the product is 1 year in service or 1.5 years after the product is delivered, whichever is first⁽¹⁾. Also, the product may have specified durability, running distance or replacement parts. Please consult your nearest sales branch.

2) For any failure or damage reported within the warranty period which is clearly our responsibility, a replacement product or necessary parts will be provided.

This limited warranty applies only to our product independently, and not to any other damage incurred due to the failure of the product.

3) Prior to using SMC products, please read and understand the warranty terms and disclaimers noted in the specified catalogue for the particular products.

⁽¹⁾ Vacuum pads are excluded from this 1 year warranty.

A vacuum pad is a consumable part, so it is warranted for a year after it is delivered. Also, even within the warranty period, the wear of a product due to the use of the vacuum pad or failure due to the deterioration of rubber material are not covered by the limited warranty.

• **Compliance Requirements**

1) The use of SMC products with production equipment for the manufacture of weapons of mass destruction (WMD) or any other weapon is strictly prohibited.

2) The exports of SMC products or technology from one country to another are governed by the relevant security laws and regulations of the countries involved in the transaction. Prior to the shipment of a SMC product to another country, assure that all local rules governing that export are known and followed.

Caution

• **SMC products are not intended for use as instruments for legal metrology.**

Measurement instruments that SMC manufactures or sells have not been qualified by type approval tests relevant to the metrology

(measurement) laws of each country. Therefore, SMC products cannot be used for business or certification ordained by the metrology (measurement) laws of each country.

Warning

Do not exceed any of the specifications laid out in section 2 of this document or the specific product catalogue.

Caution

• **Leakage voltage**

Ensure that any leakage current, when the switching element is OFF, meets the following limits:

Series	VEX3121,VEX3122,VEX3221, VEX3222,VEX3321,VEX3322, VEX3421,VEX3422
DC coil	3% or less of rated voltage
AC coil	8% or less of rated voltage

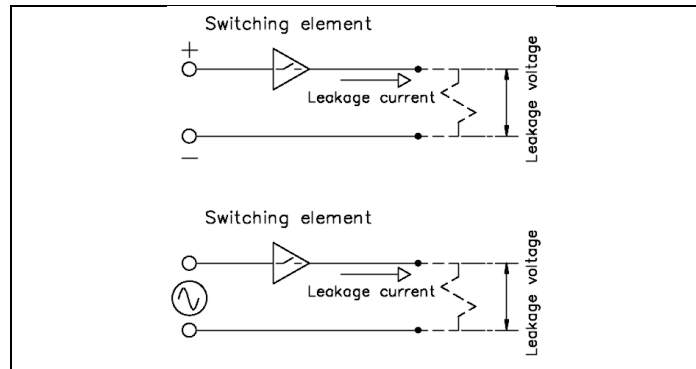

Figure 4

• **Minimum allowable load amount (Min. load current)**

When the consumption current of a valve is less than the output's minimum allowable load volume or the margin is small, the output may not switch normally. Please contact SMC.

• **Surge voltage suppressor**

If a surge protection circuit contains non-ordinary diodes such as zener diodes or varistor, a residual voltage will remain that is in proportion to the protective elements and the rated voltage.

Therefore, take into consideration surge voltage protection of the controller.

In the case of diodes, the residual voltage is approximately 1 V.

• **Low temperature operation**

Unless otherwise indicated in the specifications for each valve, operation is possible to -10°C, but appropriate measures should be taken to avoid solidification or freezing of drainage and moisture, etc.

• **Mounting orientation**

Mounting orientation is free.

8 Contacts

AUSTRIA	SMC Pneumatik GmbH, Girakstrasse 8, AT-2100 Korneuburg, Austria
BELGIUM	SMC Pneumatics N.V./S.A. Nijverheidsstraat 20, B-2160 Wommelgem, Belgium
BULGARIA	SMC Industrial Automation Bulgaria EOOD, Business Park Sofia, Building 8-6th floor, BG-1715 Sofia, Bulgaria
CROATIA	SMC IndustrijskaAutomatikad.o.o. ZagrebačkaAvenija 104,10 000 Zagreb
CZECH REP.	SMC Industrial Automation CZ s.r.o. Hudcova 78a, CZ-61200 Brno, Czech Republic
DENMARK	SMC Pneumatik A/S,Egeskovvej 1, DK-8700 Horsens, Denmark
ESTONIA	SMC Pneumatics Estonia Oü,Laki 12, EE-10621 Tallinn, Estonia
FINLAND	SMC Pneumatics Finland Oy, PL72, Tiistiniityntie 4, SF-02031 Espoo, Finland
FRANCE	SMC Pneumatique SA.1, Boulevard de Strasbourg, Parc Gustave Eiffel, Bussy Saint Georges, F-77607 Marne La ValleeCedex 3, France

GERMANY	SMC Pneumatik GmbH, Boschring 13-15, 63329 Egelsbach, Germany
GREECE	SMC Italia Hellas Branch, Anagenniseos 7-9-P.C. 14342 N.Philadelphia, Athens, Greece
HUNGARY	SMC Hungary IpariAutomatizálásiKft.Torbágy u. 19, HU-2045 Törökbálint, Hungary
IRELAND	SMC Pneumatics (Ireland) Ltd.2002 Citywest Business Campus, Naas Road, Saggart, Co. Dublin, Ireland
ITALY	SMC Italia S.p.A.Via Garibaldi 62, I-20061Carugate, (Milano), Italy
LATVIA	SMC Pneumatics Latvia SIA, Dzelzavas str. 120g, Riga, LV-1021, Latvia
LITHUANIA	UAB "SMC Pneumatics", Oslo g. 1, LT-04123 Vilnius, Lithuania
NETHERLANDS	SMC Pneumatics B.V.De Ruyterkade 120, NL-1011 AB Amsterdam, the Netherlands
NORWAY	SMC Pneumatics Norway AS, Vollsveien 13 C, GranfosNæringspark, N-1366 Lysaker, Norway
POLAND	SMC Industrial Automation Polska Sp. z o.o.ul. Konstruktorska 11A, PL-02-673 Warszawa, Poland
PORTUGAL	SMC España S.A. Zuazobidea 14, 01015 Vitoria, Spain
ROMANIA	SMC Romania S.r.l. StrFrunzei 29, Sector 2, Bucharest, Romania
RUSSIA	SMC Pneumatik LLC. Business centre, building 3, 15 Kondratjevskij prospect, St.Petersburg, Russia, 195197
SLOVAKIA	SMC PriemyselnaAutomatizáciaSpols.r.o. Fantranská 1223, Teplickanadvahom, 01301, Slovakia
SLOVENIA	SMC IndustrijskaAvtomatikad.o.o. Mirskacesta 7, SLO-8210 Trebnje, Slovenia
SPAIN	SMC España S.A. Zuazobidea 14, 01015 Vitoria, Spain
SWEDEN	SMC Pneumatics Sweden AB,Ekhagsvägen 29-31, SE-141 71 Segeltorp, Sweden
SWITZERLAND	SMC Pneumatik AG,Dorfstrasse 7, Postfach, 8484 Weissingen, Switzerland
TURKEY	SMC PnömatikSanayiTicaretveServis A.Ş. GülbaharCaddesi, Aydın Plaza, No: 9/4 Güneşli – 34212 , Istanbul
UK	SMC Pneumatics (U.K.) Ltd. Vincent Avenue, Crownhill, Milton Keynes, Buckinghamshire MK8 0AN, United Kingdom

SMC Corporation

URL : [http:// www.smcworld.com](http://www.smcworld.com) (Global) [http:// www.smceu.com](http://www.smceu.com) (Europe)

'SMC Corporation, Akihabara UDX15F, 4-14-1, Sotokanda, Chiyoda-ku, Tokyo 101 0021

Specifications are subject to change without prior notice from the manufacturer.

© 2016 SMC Corporation All Rights Reserved.